

Features

- Provides an interface between the Altera pci_mt32 MegaCore[®] function and a 32-bit, 16-MByte SDRAM module
- Supports 32-bit PCI master and target transactions
- Supports chaining and non-chaining mode direct memory access (DMA)
- Uses the FIFO function from the library of parameterized modules (LPM)
- Uses the Altera SDR SDRAM controller reference design

General Description

This reference design is a design example that illustrates how to interface local logic to the pci_mt32 MegaCore function. The reference design includes a target and a master interface to the pci_mt32 function and the SDRAM memory. The DMA engine is implemented in the local logic to enable the pci_mt32 function to operate as a bus master. The design implements a FIFO interface to solve latency issues when data is transferred between the PCI bus and the SDRAM.

Figure 1 shows a high-level block diagram of the reference design. The reference design consists of the following elements:

- Master control logic
- Target control logic
- DMA engine
- Data path FIFO functions
- SDRAM interface

Figure 1. Block Diagram

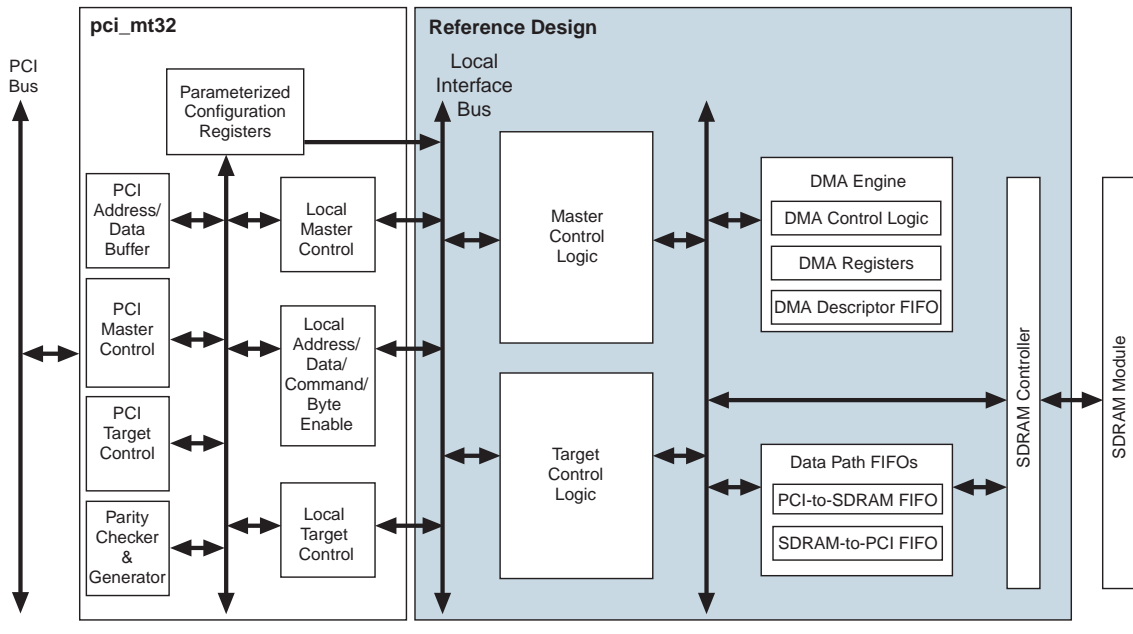

Master Control Logic

When the `pci_mt32` function is used as a master, the master control logic interacts with the DMA engine to control the PCI master transactions. During a PCI master write, the data flows from the local master to the PCI bus. The master control logic:

- Provides status of the PCI bus to the DMA engine
- Interacts with the `pci_mt32` function to execute a PCI master write
- Transfers the data from the SDRAM-to-PCI FIFO to the `pci_mt32` function

During a PCI master read, the data flows from the PCI bus to the local master. The master control logic:

- Provides the status of the PCI bus to the DMA engine
- Interacts with the PCI function to execute the PCI master read
- Buffers the data read by the `pci_mt32` function into the PCI-to-SDRAM FIFO

Target Control Logic

When the PCI function acts as a target, the `pci_mt32` function prompts the target control logic to execute target transactions. During a PCI target write, the data flows from PCI bus to the local target. The target control logic performs the following functions:

- Interacts with the `pci_mt32` function to execute a PCI target write
- Buffers the data—written by the host or the master on the PCI bus—into the PCI-to-SDRAM FIFO
- Interacts with the SDRAM controller to read data from the PCI-to-SDRAM FIFO and write into SDRAM

During a PCI target read, the data flows from local target to the PCI bus. The target control logic performs the following functions:

- Interacts with the `pci_mt32` function to execute a PCI target read
- Interacts with the SDRAM controller to fetch the data from the SDRAM
- Transfers the data from the SDRAM-to-PCI FIFO to the `pci_mt32` function

DMA Engine

The DMA engine interfaces with the master control logic, the data path FIFO buffers, and the SDRAM interface to coordinate DMA transfers to and from the SDRAM. The DMA engine consists of the following elements:

- DMA control logic
- DMA registers
- DMA descriptor FIFO buffers

DMA Control Logic

The DMA control logic performs the following functions:

- Provides control signals to the master control logic to prompt it to request the PCI bus when needed.
- Triggers a new access to the SDRAM
- Monitors the data path FIFO buffers and the current SDRAM access
- Monitors the DMA registers in order to initiate a new transaction
- Loads the address counter register (ACR) and byte counter register (BCR) in the DMA registers when DMA is in chaining mode
- Updates the interrupt status register (ISR) and control and status register (CSR) in the DMA registers (chaining and non-chaining mode)

DMA Registers

Setting up the DMA registers in the DMA engine initiates DMA transactions. These registers are memory-mapped to BAR0 of the pci_mt32 function. The DMA registers can be accessed with a target transaction to their memory-mapped addresses. The registers must be written by another master on the PCI bus, or the host. The 5 DMA registers are identified as follows:

- Control and status register (CSR)
- Address counter register (ACR)
- Byte counter register (BCR)
- Interrupt status register (ISR)
- Local address counter (LAR)

Detailed description of these registers is provided in [“DMA Engine” on page 15](#).

DMA Descriptor FIFO

The DMA Descriptor FIFO buffer provides the storage area for a series of byte count and PCI address pairs when the DMA is programmed to operate in chaining mode. The size of the descriptor FIFO buffer is 256 x 32, and it is capable of holding up to 128 DMA transactions in a chain. This FIFO buffer must be written with byte count and address pairs by another master/host on the PCI bus before starting the DMA in chaining mode. The descriptor FIFO buffer is read by the DMA control logic to fetch the current byte count to the BCR and address to the ACR before executing the next DMA transaction in a chain.

Data Path FIFO Buffers

The data path FIFO buffers serve as the buffer space for the data flowing between the SDRAM and PCI bus. The FIFO buffers are needed to resolve the SDRAM's high data-access latency. The reference design implements the following FIFO buffers:

- PCI-to-SDRAM FIFO (128 x 32)
- SDRAM-to-PCI FIFO (128 x 32)

PCI-to-SDRAM FIFO Buffer

This FIFO buffer stores data transferred from the PCI bus to the SDRAM. It is used during PCI target write and master read transactions. During these transactions, data written into the FIFO buffer is controlled by the target and master control logic, respectively. The SDRAM interface module reads the data from the FIFO buffer.

SDRAM-to-PCI FIFO Buffer

The SDRAM-to-PCI FIFO buffers the data transferred from the SDRAM to the PCI bus. This FIFO buffer is used during PCI target read and master write transactions. During the target read and master write transactions, the SDRAM controller controls data written into this FIFO buffer. The target or master control modules control reading data from this FIFO buffer.

SDRAM Controller

The SDRAM controller controls the read and write operation from the SDRAM module. The SDRAM controller logic consists of an Altera SDR SDRAM controller and interface logic to connect the DMA engine, data path FIFO buffers, master control logic, and target control logic to the SDRAM controller.

Functional Description

The `pci_mt32` function used in this reference design implements two base address registers (BARs): `BAR0` and `BAR1`. `BAR0` is set to reserve 1 MByte of system address space to map all the local read/write registers and the descriptor FIFO buffer. `BAR1` is set to reserve 16 MBytes of the system address space to map to a 16-MByte SDRAM module.

Memory Mapping

`BAR0` reserves 1 MByte of the system address space; the 12 most significant bits of the PCI address are decoded by the `pci_mt32` function to claim a target transaction. All of the DMA registers and the descriptor FIFO buffer are mapped to this address space. This reserved space is divided into two equal regions of 512 KBytes each: the upper memory region is used for the DMA FIFO buffer and the lower region is used to map the DMA registers.

`BAR1` reserves 16 MBytes of the system address space; the 8 most significant bits of the PCI address are decoded by the `pci_mt32` function to claim a target transaction. This memory space is mapped to the 16-MByte SDRAM module. [Table 1](#) describes the `pci_mt32` BAR mapping.

Table 1. Memory Address Space

Memory Region	Block Size	Address Offset	Description
BAR0	512 KBytes	00000h-7FFFFh	Internal SDRAM configuration registers.
	512 KBytes	80000h-FFFFFFh	DMA descriptor FIFO buffer for chaining DMA operation.
BAR1	16 MBytes	000000h-FFFFFFFh	16-MBytes SDRAM module.

Table 2 describes the internal registers and descriptor FIFO buffer memory-mapped addresses.

Table 2. Internal Registers & DMA FIFO Memory Maps

Range Reserved	Read/Write	Mnemonic	Register Name
00000h-00003h	Read/Write	CSR[8:0]	DMA Control/Status
00004h-00007h	Read/Write	ACR[31:0]	DMA Address Counter
00008h-0000Bh	Read/Write	BCR[16:0]	DMA Byte Counter
0000Ch-0000Fh	Read	ISR[6:0]	DMA Interrupt/Status
00010h-00013h	Write	LAR[25:0]	Local Address
00018h-0001Bh	Write	SDRAM_BASE_ADDR	SDRAM Configuration
0001Ch-0001Fh	Write	SDRAM_CFG_REG0	SDRAM Configuration
00020h-00023h	Write	SDRAM_CFG_REG1	SDRAM Configuration
00024h-00027h	Write	SDRAM_CFG_REG2	SDRAM Configuration
80000h-FFFFFFh	Write	DMA_FIFO	DMA Descriptor FIFO buffer

Target Transactions

Table 3 describes the local signals of the pci_mt32 function used in this reference design. For more information on the pci_mt32 function local signals, refer to the *PCI MegaCore Function User Guide*.

<i>Table 3. Local Signals Using in Target Transactions</i>		
Type	Signal	Description
Data path input	l_adi	Local address/data input. This signal is driven with data by the local side during PCI bus-initiated target read transactions.
Data path output	l_dato	Local data output. The PCI function drives data on this bus during target write transactions.
	l_adro	Local address output. The PCI function drives address on this bus during target read and write transactions.
	l_beno	Local byte-enable output. The PCI function drives a byte enable on this bus during target read and write transactions.
	l_cmndo	Local command output. The PCI function drives commands on this bus during target operation.
Local target control inputs	lt_rdyn	Local target ready. The local side asserts this signal to indicate valid data input during a target read, or to indicate that it is ready to accept data input during a target write.
	lt_discn	Local target disconnect request. This signal requests the PCI function to issue a retry or a disconnect depending on when the signal is asserted during a transaction.
	lt_abortn	Local target abort request. This signal requests the PCI function to issue a target abort to the PCI master.
Local target control outputs	lt_framen	Local target frame request. This signal is asserted while the PCI function is requesting access to the local side. It is asserted one clock cycle before the functions asserts <code>devseln</code> , and it is released after the last data phase of the transaction is transferred to/from the local side.
	lt_ackn	Local target acknowledge. The PCI function asserts this signal to indicate valid data output during a target write, or to indicate that it is ready to accept data during a target read.
	lt_dxfrn	Local target data transfer. The PCI function asserts this signal when a data transfer on the local side is successful during a target transaction.
	lt_tsr[11..0]	Local target transaction status register. The <code>lt_tsr[11..0]</code> bus carries several signals, which can be monitored for the transaction status.

Figure 2 provides a block diagram of the target reference design.

Figure 2. Target Reference Design

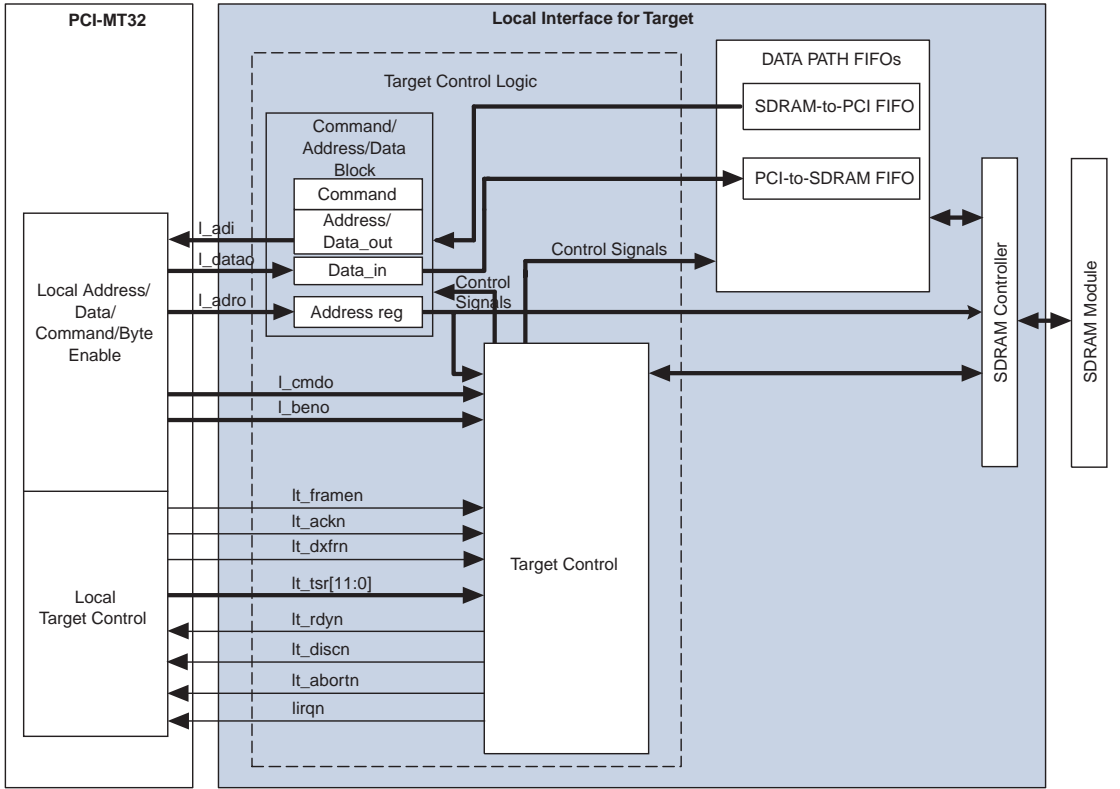

During the address phase of a PCI target transaction, the `pci_mt32` function compares the PCI address with the BAR0 and BAR1 address ranges; if the address decoded matches the address space reserved for BAR0 or BAR1, the function asserts the `devseln` signal on the PCI bus to claim the transaction.

After the target transaction has been claimed by the `pci_mt32`, the `pci_mt32` asserts the `lt_framen` signal and the appropriate `lt_tsr[11..0]` signal on the local side to indicate to the target control logic that a target transaction has been requested.

The target control logic uses `l_adro[19]` and the `lt_tsr[1..0]` signals from the `pci_mt32` function to determine if the current transaction is for SDRAM, the DMA registers, or the DMA FIFO buffer. It also decodes `l_cmdo[3..0]` to determine whether the transaction is a memory read or write.

The command/address/data (CAD) block in the target control logic uses the data path input from the function to provide relevant data to target control and data path FIFO buffers. The CAD uses data path outputs from the target control and the data path FIFO buffers to provide relevant data to the local side of the pci_mt32 function. The CAD block is common to both the target control logic and master control logic.

PCI Target Memory Read

When a target memory read is decoded:

- A retry is signaled immediately by asserting the `lt_discn` signal to the pci_mt32 function, due to the SDRAM requirement of more than 16 clock cycles to provide the initial data to the SDRAM-to-PCI FIFO buffer. All memory read cycles are treated as delayed transactions.
- While waiting for the SDRAM-to-PCI FIFO buffer to be filled to a predetermined number of DWORDS (threshold), all memory target transactions are retried and only target access to the internal registers is accepted.
- After the threshold has been reached, the target control asserts `lt_rdyn` to accept a memory read cycle with the same address as that of the read cycle for which the retry was terminated.
- The data from the SDRAM-to-PCI FIFO buffer is transferred to the PCI bus until the `lt_framen` signal is deasserted by the pci_mt32 function.
- If the number of data words in the FIFO buffer falls below a predetermined value, `lt_discn` is asserted to end the current target read since the SDRAM can not keep supplying the read data on time. Subsequently, the master has to re-read the rest of the data.
- On deassertion of `lt_framen` signal, the remaining data in the SDRAM-to-PCI FIFO buffer is discarded and the FIFO buffer is flushed.

PCI Target Memory Write

When a target memory write is decoded:

- The local control logic writes the data to the PCI-to-SDRAM FIFO buffer until `lt_framen` is deasserted by the pci_mt32 function.
- On the PCI-to-SDRAM FIFO buffer read port, the SDRAM interface reads the data from the PCI-to-SDRAM FIFO buffer and writes it into the SDRAM until the FIFO buffer becomes empty and the target transaction ends.
- If the FIFO buffer becomes almost full during the target write transaction, `lt_discn` is asserted to stop the data being written into the

FIFO buffer. The master has to re-initiate a write cycle to complete writing the rest of the data from where it left off.

- On termination of a target write transaction, all target memory transactions are retried until the SDRAM controller has completed writing the data from the PCI-to-SDRAM FIFO buffer into the SDRAM.

DMA Register Access

The DMA register can be accessed via target transactions with the appropriate memory-mapped address. Refer to “Memory Mapping” on page 5 for more information. All PCI target transactions to the DMA registers are single-cycle transactions. The DMA descriptor FIFO buffer can accept single-cycle or burst writes.

Master Transactions

Table 4 describes the local signals of the pci_mt32 function used in this reference design. For more information on the local signals of the pci_mt32 function, refer to the *PCI MegaCore Function User Guide*.

Type	Signal	Description
Data path input	l_adi	Local address/data input. This signal is a local-side time multiplexed address/data bus. During master transactions, the local side must provide address on this bus when lm_adr_ackn is asserted. Data is driven on this bus from the local side during master write transaction.
	l_cbeni	Local command/byte enable input. This bus is a local-side time multiplexed command/byte enable bus. During master transactions, the local side must provide the command on l_cben when lm_adr_ackn is asserted. The local master device must provide the byte-enable value on l_cbeni during the next clock after lm_adr_ackn is asserted.
Data path output	l_dato	Local data output. The PCI function drives data on this bus during local-side initiated master read transaction.
Local master control inputs	lm_req32n	Local master request 32-bit data transaction. The local side asserts this signal to request ownership of the PCI bus for a 32-bit master transaction.
	lm_rdyn	Local master ready. The local side asserts the lm_rdyn signal to indicate a valid data input during a master write, or ready to accept data during a master read.
	lm_lastn	Local master last. This signal is driven by the local side to request the function master interface to end the current transaction. When the local side asserts this signal, the megafunction master interface deasserts framen as soon as possible and asserts lt_rdyn to indicate that the last data phase has begun.

Table 4. Signals Used in Master Transactions (Part 2 of 2)

Type	Signal	Description
Local master control outputs	lm_addr_ackn	Local master address acknowledge. The PCI function asserts lm_addr_ackn to the local side to acknowledge the requested master transaction. During the same clock cycle lm_addr_ackn is asserted low, the local side must provide the transaction address on the l_adi bus and the transaction command on the l_cbeni.
	lm_ackn	Local master acknowledge. The PCI function asserts this signal to indicate valid data output during a master read, or ready to accept data during a master write.
	lm_dxfrn	Local master data transfer. The PCI function asserts this signal when a data transfer on the local side is successful during a master transaction.
	lm_tsr[9..0]	Local master transaction status register. These signals inform the local interface the progress of the transaction.

Figure 3 shows a block diagram of the master portion of the reference design.

The command/address/data (CAD) block in the master control logic uses the data path input from the function to provide relevant data to the master control and data path FIFO buffers. The CAD uses data path outputs from the master control and the data path FIFO buffers to provide relevant data to the local side of the pci_mt32 function. The CAD block is common to target control logic and master control logic.

PCI Master Read

To initiate a master read transaction:

- The master control logic requests the bus by asserting the `lm_req32n` signal to the local side of the pci_mt32 function for a 32-bit transaction.
- At the same time, the DMA engine signals the SDRAM interface to request an SDRAM write access.
- The PCI function asserts `reqn` to request the PCI bus and simultaneously asserts `lm_tsr[0]` from the local side to indicate that the master is requesting the PCI bus.
- Upon receiving the `gntn` signal from the arbiter, the pci_mt32 function asserts the `lm_adr_ackn` and `lm_tsr[1]` local side signals, indicating that the bus has been granted and the local side must supply the starting address and command. The master control provides the PCI address on `l_adi` and the PCI command on `l_cbeni` during the same clock cycle that the `lm_adr_ackn` and `lm_tsr[1]` signals are asserted.
- The master control asserts the `lm_rdyn` input to the pci_mt32 function to indicate that it is ready to accept data.
- The pci_mt32 function asserts `lm_ackn`, indicating to the master control that it has registered data from the PCI side on the previous clock cycle and is ready to send data to the local side master interface. Because `lm_rdyn` was asserted in the previous clock cycle and `lm_ackn` is asserted in the current cycle, the function asserts `lm_dxfrn` to indicate a valid data transfer on the local side.
- The pci_mt32 function also asserts `lm_tsr[8]`, indicating to the master control that a data phase was completed successfully on the PCI bus during the previous clock.
- The SDRAM interface logic reads one DWORD (32 bits) of data at a time from the PCI-to-SDRAM FIFO buffer and writes it into the SDRAM memory. During a master read transaction, the master control logic asserts the `stop` signal to the DMA and the SDRAM interface if the master must release the bus prematurely. The `lm_lastn` signal is asserted to the core to end the transaction normally, i.e., all data has been received. When the `lm_lastn` signal is asserted, the core deasserts `framen` as soon as possible and asserts `irdyn` to read the last data on the PCI bus. Additionally, the SDRAM interface transfers all valid data from the PCI-to-SDRAM FIFO buffer

and stops the operation. If the master has not read all of the data from the target due to premature termination, the master control logic and the DMA engine start a new master read cycle to read the remaining data.

- If the SDRAM cannot empty the FIFO fast enough and the FIFO is almost full the master control logic asserts the stop signal to request the DMA and the PCI-mt32 master function to end the current transaction to prevent FIFO-buffer overflow.
- If the latency timer expires, the pci_mt32 function will stop the current master transaction and assert the lm_tsr[4] to indicate a premature termination of the current transfer. The master control logic and the DMA engine monitor this signal and react accordingly.

PCI Master Write

To initiate a master write transaction:

- The DMA sends a signal to the SDRAM interface to request SDRAM read access.
- The master control logic waits for the SDRAM-to-PCI FIFO buffer to be filled with a predetermined number of DWORDs before requesting the PCI bus. This action ensures that the master does not violate PCI latency protocol because of slow SDRAM reads.
- If the transfer count is less than 32 DWORDs, the master control logic waits for all of the data to be ready in the SDRAM-to-PCI FIFO buffer before requesting the bus.
- If the transfer count is more than or equal to 32 DWORDs, it waits for 32 DWORDs to be written into the FIFO buffer before requesting the bus by asserting lm_req32n signal.
- On receiving gntn, the pci_mt32 function asserts lm_tsr[1] and lm_adr_ackn. This action indicates to the local side that the bus has been granted and the local side must provide a valid address and command on l_adi and l_cbeni, respectively.
- The master control logic asserts lm_rdyn to the pci_mt32 function to indicate that it is ready to transfer the data from SDRAM-to-PCI FIFO buffer.
- The pci_mt32 function asserts lm_ackn during the first data phase on the local side, even if the PCI side is not ready to transfer data. During subsequent data phases, the pci_mt32 function does not assert lm_ackn unless the PCI side is ready to accept data. Because the master control asserted lm_rdyn during the previous clock cycle and lm_ackn is asserted in the current cycle, the PCI function asserts lm_dxfrn to indicate a valid data transfer on the local side.
- Premature termination may occur if the latency timer is expired, the target disconnects, or the target retries.

If a master write transaction is terminated prematurely, the master control logic asserts the stop signal to DMA and the `abort` signal to the SDRAM interface. The local control logic continues to flush the SDRAM-to-PCI FIFO buffer until the SDRAM interface completes the current write to the FIFO buffer, and the transaction will be restarted to transfer the rest of data. The `lm_lastn` signal is asserted to end the transaction normally.

DMA Engine

This section describes the `pci_mt32` DMA engine.

DMA Registers

The DMA reference design implements the following registers:

- Control and status register (CSR)
- Address counter register (ACR)
- Byte counter register (BCR)
- Interrupt status register (ISR)
- Local address counter (LAR)

These registers are memory-mapped to `BAR0` of the `pci_mt32` function and must be configured by another master/host on the PCI bus.

Control & Status Register (CSR)

The control and status register is a 9-bit register and is used to configure the DMA engine. The CSR directs the DMA operation and provides the status of the current memory transfer. The CSR can be written/read by another master on the PCI bus. [Table 5](#) describes the format of the CSR.

Table 5. DMA Control & Status Register Format (Part 1 of 2)

Data Bit	Mnemonic	Read/Write	Definition
0	<code>int_ena</code>	Read/Write	PCI interrupt enable.
1	<code>flush</code>	Write	Flush the buffer. When high, it flushes the DMA FIFO buffer to empty and resets <code>dma_tc</code> and <code>ad_loaded</code> (bits 3 and 4 of the ISR). The <code>flush</code> bit resets itself; therefore, it always zero when read. The <code>flush</code> bit should never be set when the <code>dma_on</code> bit is set because a DMA transfer is in progress.
2	–	–	Reserved.
3	<code>write</code>	Read/Write	Memory read/write. The <code>write</code> bit determines the direction of the DMA transfer. When <code>write</code> is high, the data flows from the SDRAM to PCI bus (master write); when low, data flows from the PCI bus to the SDRAM (master read).

Data Bit	Mnemonic	Read/Write	Definition
4	dma_ena	Read/Write	DMA enable. When high, dma_ena allows the DMA engine to respond to DMA requests as long as the PCI bus activity is not stopped due to a pending interrupt.
5	tci_dis	Read/Write	Transfer complete interrupt disable. When high, tci_int disables dma_tc (bit 3 of the ISR) from generating PCI bus interrupts.
6	dma_on	Read/Write	DMA on. When high, dma_on indicates that the DMA engine can request ownership of the PCI bus. The dma_on bit is high when: <ul style="list-style-type: none"> ■ The ACR is loaded (bit 4 of ISR). ■ The DMA is enabled. ■ There is no error pending. ■ The DMA transfer sequence begins when dma_on is set. Under normal conditions (i.e., DMA is enabled and no error is pending), dma_on is set when a write transaction to the ACR occurs via a target write.
7	–	–	Reserved.
8	chain_ena	Read/Write	Chaining mode enable. When high, chain_ena indicates that the current DMA request is in chaining mode and the DMA descriptor FIFO buffer has the information for the DMA transfers.

DMA Address Counter (ACR)

The address counter is a 32-bit register. The ACR is implemented with a 30-bit counter and the 2 least significant bits are tied to ground. The ACR contains the PCI bus address for the current memory transfer and is incremented after every data phase on the PCI bus. The PCI bus memory transfer initiated by the DMA engine must begin at the DWORD boundary. The ACR can be written/read by the PCI bus master. Table 6 shows the format of the ACR. The ad_loaded bit triggers the beginning of the DMA operation because it sets the dma_on bit in the CSR. It is automatically set when the write to the ACR occurs. Therefore, the ACR must be written last when setting up the DMA register.

Data Bit	Name	Read/Write	Definition
1..0	ACR	Read	Ground.
31..2	ACR	Read/write	30-bit counter.

DMA Byte Counter (BCR)

The DMA byte counter is a 18-bit register. The BCR is implemented with a 15-bit counter and the 2 least significant bits are tied to ground. The BCR holds the byte count for the current DMA memory transfer and decrements (by 4 bytes) after every data transfer on the PCI bus. The BCR can be written/read by the PCI bus master. [Table 7](#) shows the format of the BCR.

<i>Table 7. DMA Byte Counter Format</i>			
Data Bit	Name	Read/Write	Definition
1..0	BCR	Read	Ground.
16..2	BCR	Read/Write	15-bit down counter.
31..17	Unused	–	–

Interrupt Status Register (ISR)

The interrupt and status register is a 6-bit register. The ISR provides all interrupt source status signals to the interrupt handler. The ISR is a read-only register and can be read by another master on the PCI bus. [Table 8](#) shows the format of the ISR.

<i>Table 8. Interrupt Status Register Format (Part 1 of 2)</i>			
Data Bit	Mnemonic	Read/Write	Definition
0	int_pend	Read	Interrupt pending. The DMA engine asserts <code>int_pend</code> to indicate that the DMA interrupt is pending. The possible interrupt signals are <code>err_pend</code> and <code>dma_tc</code> .
1	err_pend	Read	Error pending. When high, <code>err_pend</code> indicates that an error has occurred during the DMA memory transfer. The interrupt handler must read the PCI configuration status register and clear the appropriate bits. Any one of the following PCI status register bits can assert <code>err_pend</code> : <code>mstr_abrt</code> , <code>tar_abrt</code> , and <code>det_par_err</code> .
2	int_irq	Read	Interrupt request. When high, <code>int_irq</code> indicates that the local logic is requesting an interrupt, i.e., the <code>l_irqn</code> signal to the <code>pci_mt32</code> function is asserted.

<i>Table 8. Interrupt Status Register Format (Part 2 of 2)</i>			
Data Bit	Mnemonic	Read/Write	Definition
3	dma_tc	Read	<p>DMA terminal count. When high, <code>dma_tc</code> indicates that the DMA transfer is complete. The <code>dma_tc</code> bit is reset with any of the following three conditions:</p> <ul style="list-style-type: none"> ■ A read transaction to the ISR. ■ A write transaction to the CSR. ■ A write transaction to the ACR.
4	ad_loaded	Read	<p>Address loaded. When high, <code>ad_loaded</code> indicates that the address has been loaded in the ACR. This bit is cleared if any of the following conditions occur:</p> <ul style="list-style-type: none"> ■ The DMA operation completes and the <code>dma_tc</code> bit is set. ■ The flush bit is set. ■ The PCI bus is reset with <code>rstn</code> going low. ■ The <code>ad_loaded</code> bit triggers the beginning of the DMA operation because it sets the <code>dma_on</code> bit in the CSR. It is automatically set when the write to the ACR occurs; therefore, the ACR must be written last when setting up the DMA register.
5	start_chain	Read	<p>Start chaining mode. This bit is used in DMA chaining mode only. When high, it indicates that the CSR has been loaded and the <code>chain_enable</code> bit of the CSR is set. This bit is cleared if one of the following conditions occurs:</p> <ul style="list-style-type: none"> ■ The DMA operation completes and the <code>dma_tc</code> bit is set. ■ The flush bit is set. ■ The PCI bus is reset with <code>rstn</code> going low. ■ <code>start_chain</code> triggers the beginning of the chaining DMA by setting the <code>dma_on</code> bit in the CSR register.

Local Address Counter Register (LAR)

The local address counter register (LAR) is a 26-bit register. The LAR holds the SDRAM address from which the data will be transferred to/from the SDRAM. It is implemented with a 24-bit counter and the 2 least significant bits are tied to ground. This register decrements after every data phase transfer. The LAR is a write-only register. Table 9 shows the format of the LAR.

Data Bit	Name	Read/Write	Definition
1..0	LAR	Write	Ground.
25..2	LAR	Write	24-bit down counter.
31..26	Unused	–	–

DMA Operation

This section describes the operation of the DMA in non-chaining and chaining mode.

Non-Chaining Mode

To operate the DMA in non-chaining mode, the DMA registers must be written in the following sequence:

1. Write the CSR register with the appropriate value (`chain_enable` bit = 0).
2. Write the LAR register with the SDRAM starting address of the transaction.
3. Write the BCR with the number of bytes to be transferred.
4. Write the ACR with the starting PCI address for the transaction.

After the ACR is loaded with the PCI address, the `ad_loaded` bit in the ISR register is set and the DMA state machine is triggered. In the subsequent clock cycle, the `dma_on` bit of the CSR register is set to indicate that the DMA transfer is in progress. The DMA state machine then sends the request to signal the master control logic to request a PCI master transaction; the master control logic forwards the request to the `pci_mt32` function interface to request the PCI bus. The DMA state machine also asserts the `local_start` signal to request an SDRAM access through the SDRAM controller.

Once the bus has been granted to the `pci_mt32` master, data transfers can take place if data is available in the appropriate data FIFO buffer. If data is not available, wait state(s) will be inserted on the PCI bus. The BCR counts down after every data transfer on the PCI bus for DMA write and on the local side for DMA read until it reaches zero. The DMA control logic then sets the `dma_tc` and `int_pend` bits and resets the `ad_loaded` and `dma_on` bits to return the DMA to the idle state.

In the event of an abnormal termination of a DMA transaction where the byte counter has not expired, the DMA state machine waits for the master and SDRAM control logic to return to the idle state before requesting a new DMA transaction to transfer the remaining data.

Figure 4 shows the register set up sequence for a non-chaining mode DMA operation.

Figure 4. Non-Chaining DMA Setup Sequence

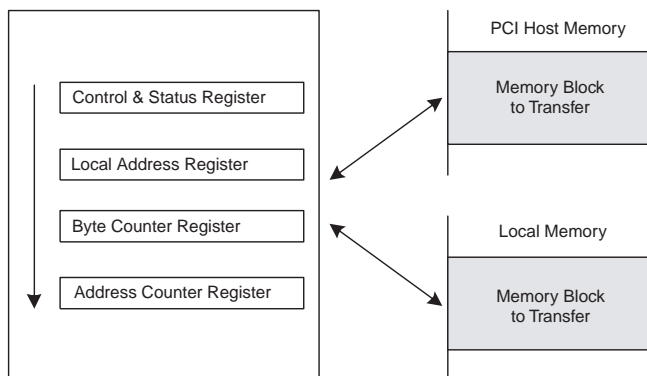

Chaining Mode

To operate the DMA in chaining mode, the descriptor FIFO buffer and the DMA registers must be written in the following sequence:

1. Target burst write the series of DMA transfer information to the DMA descriptor FIFO buffer. The DMA transfer information contains the PCI address and byte count to be transferred.
2. Write the SDRAM starting address of the transaction to the LAR.
3. Write the appropriate control data bits (`chain_enable` bit = 1) to the CSR.

When the `chain_enable` bit is set, the `start_chain` bit of the ISR will be set to indicate that the DMA is in the chain operation mode. This action triggers the loading of the first set of DMA data from the descriptor FIFO buffer to the ACR and BCR. After the ACR and BCR are loaded with valid data, the DMA state machine requests a DMA transaction. The DMA then operates similar to the non-chaining mode.

After the first DMA transfer has completed and the next set of DMA data is loaded from the descriptor FIFO buffer into the ACR and BCR, a new DMA transfer takes place. This process is repeated until the DMA FIFO buffer becomes empty, i.e., the DMA chain has ended. The DMA control logic then sets the `dma_tc` and `int_pend` bits and resets the `ad_loaded` and `dma_on` bits to return the DMA to the idle state.

Figure 5 shows the set up sequence for a chaining DMA mode operation.

Figure 5. Chaining DMA Setup Sequence

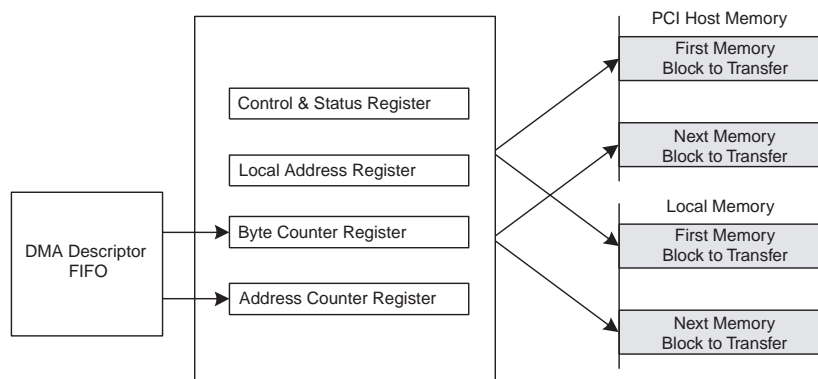

Interrupt Request

The local side logic requests an interrupt when one of the following conditions occurs:

- The DMA transaction has been completed successfully and the `dma_tc` bit of the ISR has been set.
- An error has been detected and the `err_pend` bit of the ISR has been set.

The interrupt request signal will be asserted until the appropriate bit causing the interrupt is cleared.

Designing for 66-Mhz Operation

When designing for 66-MHz operation, follow the guidelines below:

- Register all the input control signals to the PCI function or at most one level of logic. See [Figure 6](#).

Figure 6. Input Control Signals

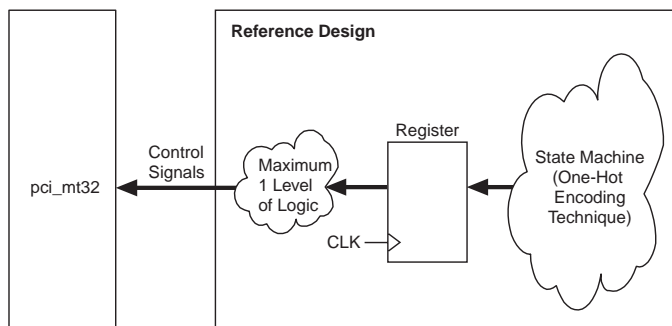

- Use one-hot encoding for all state machines.
- Register write request and the data written into the FIFO buffer.

Design File Structures

This section explains the file structure and modules used in the reference design. [Figure 7](#) shows the file structure.

Figure 7. Reference Design File Structure

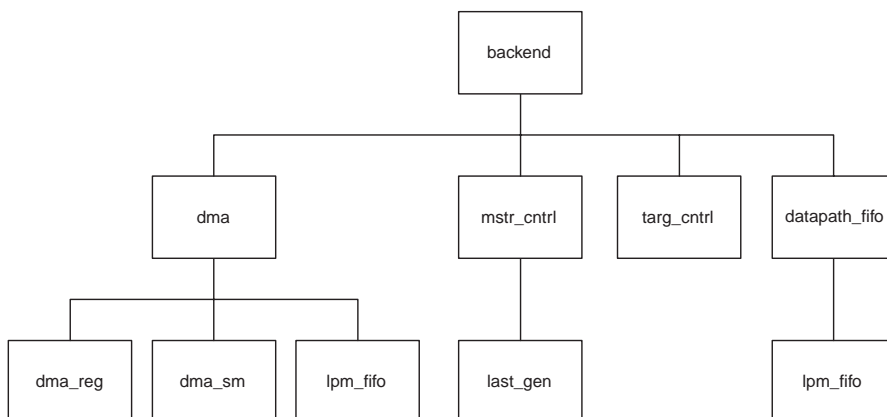

Table 10 describes the modules shown in Figure 7.

<i>Table 10. Reference Design Sub-Module Description</i>	
Module	Description
dma_reg	Write and read control. This module includes all of the DMA registers such as CSR, BCR, ACR, ISR, and LAR.
dma_sm	DMA state machines. This module provides DMA control in chaining DMA and non-chaining DMA mode.
lpm_fifo	Altera parameterizable LPM FIFO buffer.
dma	Top level of the DMA engine.
last_gen	lm_last signal generation. This module generates the lm_lastn signal for 32-bit and 64-bit master transactions.
mstr_cntrl	Master control. This module drives all the master local signals of the pci_mt32 function. It also interfaces to the DMA engine for the status of the current master transaction.
targ_cntrl	Target control. This module drives all the target local signals of the pci_mt32 function. It also connects to the SDRAM interface module to provide SDRAM access control.
datapath_fifo	Data path FIFO buffer. This module includes all of the FIFO buffers that the data transfer between the PCI function and the SDRAM. It also includes the data masking FIFO buffer.
backend	The top level of the reference design.

Figure 8 shows the structure of the SDRAM interface.

Figure 8. SDRAM Interface File Structure

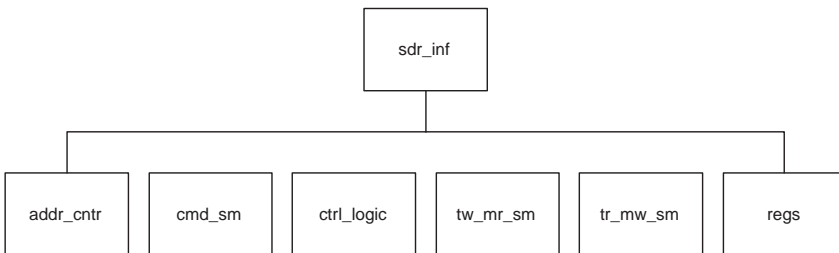

Table 11 describes the modules shown in Figure 8.

<i>Table 11. SDRAM Interface Sub-Module Description</i>	
Module	Description
addr_cnr	Address counter. This module generates the address for the SDRAM controller to store data.
cmd_sm	Command state machine. This module generates commands to the SDRAM controller.
ctrl_logic	Control logic. This module controls the read and write of the data path FIFO buffer.
tw_mr_sm	Target write or master read state machine. This module provides control signals for the data to be written into the SDRAM (target write/master read).
tr_mw_sm	Target read or master write state machine. This module provides control signals for the data to be read from the SDRAM (target read/master write).
regs	This module outputs the data that has to be loaded into the address counter, which is output as the address to the SDRAM controller during the configuration or load mode register access.

References

For more information refer to the following documents:

- [Altera PCI MegaCore Function User Guide](#)
- [Altera SDR SDRAM Controller White Paper](#)
- Micron Technology 64-Mb SDRAM data sheet

Revision History

The information contained in [Functional Specification 12: pci_mt32 MegaCore Function Reference Design](#) version 1.1 supersedes information published in previous versions.

Version 1.1

[Functional Specification 12: pci_mt32 MegaCore Function Reference Design](#) version 1.1 contains the following changes:

- Updated text throughout for 2.2.0 release of the PCI Compiler software.



101 Innovation Drive
San Jose, CA 95134
(408) 544-7000
<http://www.altera.com>
Applications Hotline:
(800) 800-EPLD
Customer Marketing:
(408) 544-7104
Literature Services:
lit_req@altera.com

Altera and MegaCore are trademarks and/or service marks of Altera Corporation in the United States and other countries. Altera acknowledges the trademarks of other organizations for their respective products or services mentioned in this document. Altera products are protected under numerous U.S. and foreign patents and pending applications, maskwork rights, and copyrights. Altera warrants performance of its semiconductor products to current specifications in accordance with Altera's standard warranty, but reserves the right to make changes to any products and services at any time without notice. Altera assumes no responsibility or liability arising out of the application or use of any information, product, or service described herein except as expressly agreed to in writing by Altera Corporation. Altera customers are advised to obtain the latest version of device specifications before relying on any published information and before placing orders for products or services.

Copyright © 2001 Altera Corporation. All rights reserved.



I.S. EN ISO 9001