



Saving Board Space with MAX 7000S & MAX 7000A TQFP Packages

February 1998, ver. 2

Board Space Savings

Altera® devices allow designers to save board space by enabling the integration of 22V10s, PALs, and GALs into higher density devices. Designers can save even more board space by using Altera MAX® 7000S and MAX 7000A devices in thin quad flat pack (TQFP) packages. [Table 1](#) shows that these packages use less board space than traditional plastic J-lead chip carrier (PLCC) and plastic quad flat pack (PQFP) packages.

Device	Density (Macrocells)	Pins	Package Type	Package Dimensions (mm)	Lead Pitch (mm)	Area (mm ²)	Size Reduction Achieved with TQFP Alternative
EPM7032S EPM7032A	32	44	PLCC	17.52 × 17.52	1.270	306.9	53%
		44	TQFP	12.00 × 12.00	0.800	144.0	–
EPM7064S EPM7064A	64	44	PLCC	17.52 × 17.52	1.270	306.9	53%
		44	TQFP	12.00 × 12.00	0.800	144.0	–
		84	PLCC	30.22 × 30.22	1.270	913.2	72%
		100	PQFP	17.19 × 23.20	0.650	398.8	36%
		100	TQFP	16.00 × 16.00	0.500	256.0	–
EPM7128S EPM7128A	128	84	PLCC	30.22 × 30.22	1.270	913.2	72%
		100	PQFP	17.19 × 23.20	0.650	398.8	36%
		100	TQFP	16.00 × 16.00	0.500	256.0	–
		160	PQFP	31.20 × 31.20	0.650	973.4	74%
EPM7160S	160	84	PLCC	30.22 × 30.22	1.270	913.2	72%
		100	PQFP	17.19 × 23.20	0.650	398.8	36%
		100	TQFP	16.00 × 16.00	0.500	256.0	–
		160	PQFP	31.20 × 31.20	0.650	973.4	74%
EPM7256A	256	100	TQFP	16.00 × 16.00	0.500	256.00	73%
		144	TQFP	22.00 × 22.00	0.500	484.0	–
		208	PQFP	30.60 × 30.60	0.500	936.4	52%
EPM7384A	384	144	TQFP	22.00 × 22.00	0.500	484.0	–
		208	PQFP	30.60 × 30.60	0.500	936.4	52%
EPM7512A	512	144	TQFP	22.00 × 22.00	0.500	484.0	–
		208	PQFP	30.60 × 30.60	0.500	936.4	52%

Figure 1 compares the sizes of TQFP, PLCC, and PQFP packages.

Figure 1. Space Savings with TQFP Packages

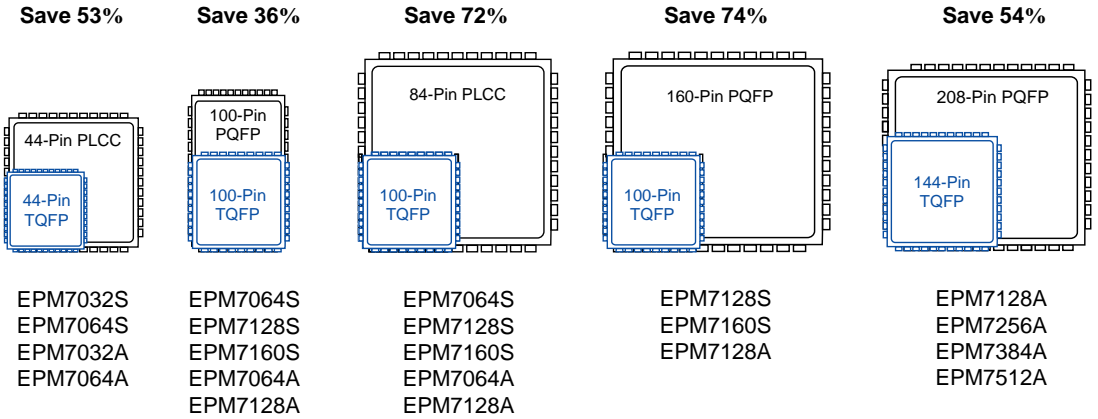

TQFP Package Outlines

Package outline dimensions are shown in the following formats:

min. inches (min. millimeters)

max. inches (max. millimeters)

or:

nominal inches ± tolerance

(nominal millimeters ± tolerance)

or:

inches BSC, Min., Max., Ref., Typ., R, Dia., Sq.
(millimeters)

Table 2 shows the units used to describe package outline dimensions.

Table 2. Package Outline Units

Unit	Description
BSC	Basic. Represents theoretical exact dimension or dimension target.
Min.	Minimum dimension specified.
Max.	Maximum dimension specified.
Ref.	Reference. Represents dimension for reference use only. This value is not a device specification.
Typ.	Typical. Provided as a general value. This value is not a device specification.
R	Radius. Represents curve dimension.
Dia.	Diameter. Represents curve dimension.
Sq.	Square. Indicates a square feature for a package with equal length and width dimensions.

Figures 2, 3, and 4 show the package outlines for MAX 7000S and MAX 7000A devices in 144-pin, 100-pin, and 44-pin TQFP packages, respectively.

Figure 2. 144-Pin Plastic TQFP Package

Controlling measurements are in millimeters, shown in parentheses. Inch measurements are for reference only.

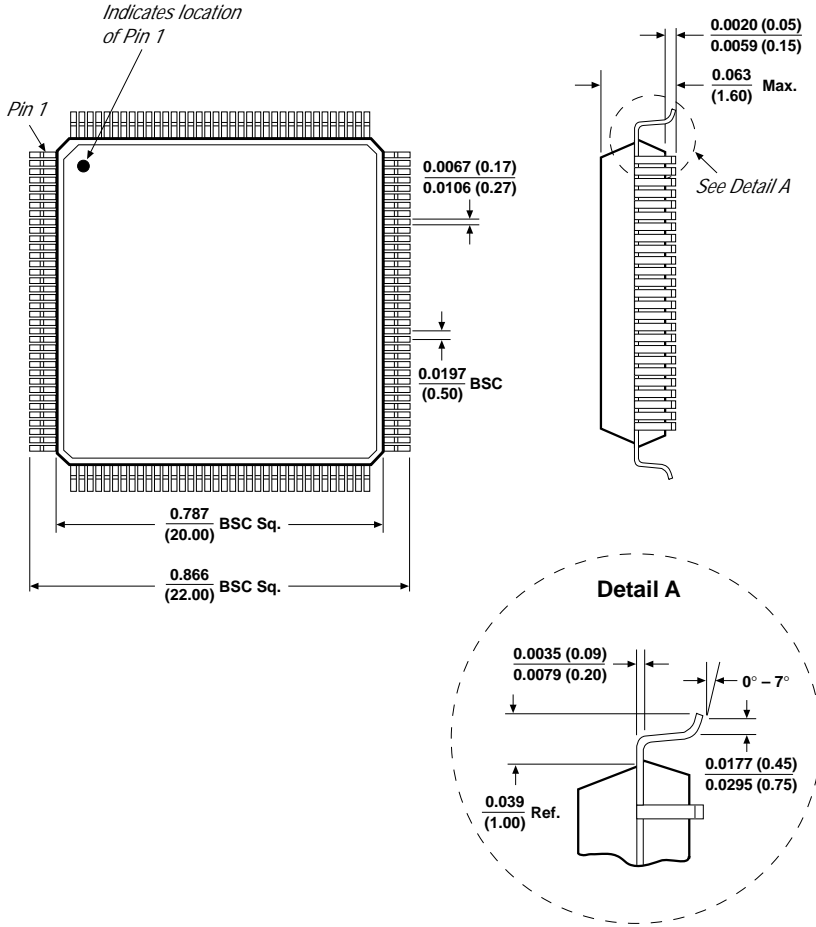

Figure 3. 100-Pin Plastic TQFP Package

Controlling measurements are in millimeters, shown in parentheses. Inch measurements are for reference only.

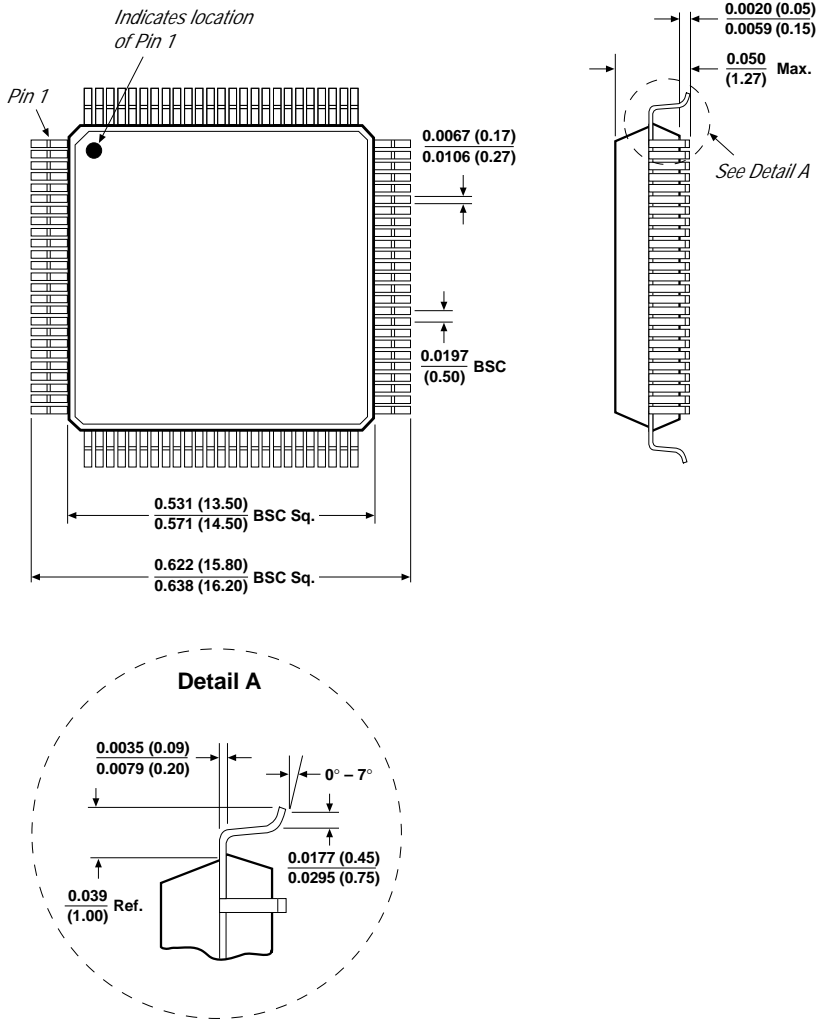
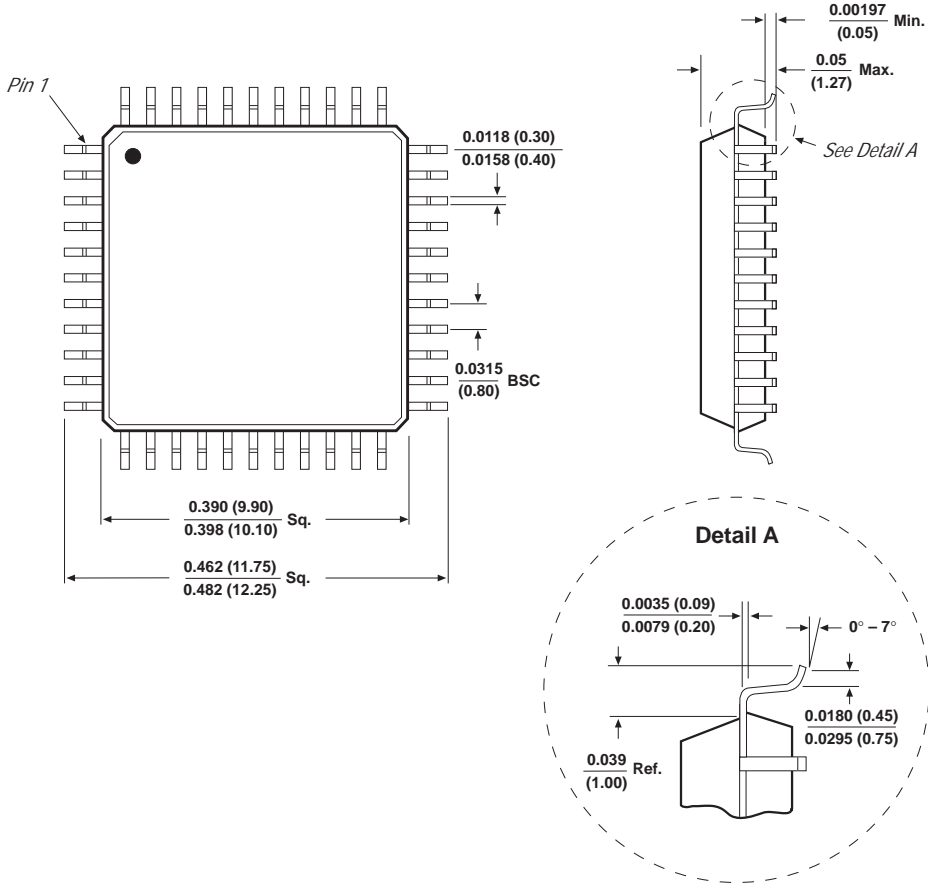

Figure 4. 44-Pin Plastic TQFP Package

Controlling measurements are in millimeters, shown in parentheses. Inch measurements are for reference only.



Copyright © 1995, 1996, 1997, 1998 Altera Corporation, 101 Innovation Drive, San Jose, CA 95134, USA, all rights reserved.

By accessing this information, you agree to be bound by the terms of Altera's Legal Notice.