



# **Transceiver Signal Integrity Development Kit, Stratix IV GT Edition Reference Manual**

---



101 Innovation Drive  
San Jose, CA 95134  
[www.altera.com](http://www.altera.com)

MNL-01052-1.1



Subscribe

© 2011 Altera Corporation. All rights reserved. ALTERA, ARRIA, CYCLONE, HARDCOPY, MAX, MEGACORE, NIOS, QUARTUS and STRATIX words and logos are trademarks of Altera Corporation and registered in the U.S. Patent and Trademark Office and in other countries. All other words and logos identified as trademarks or service marks are the property of their respective holders as described at [www.altera.com/common/legal.html](http://www.altera.com/common/legal.html). Altera warrants performance of its semiconductor products to current specifications in accordance with Altera's standard warranty, but reserves the right to make changes to any products and services at any time without notice. Altera assumes no responsibility or liability arising out of the application or use of any information, product, or service described herein except as expressly agreed to in writing by Altera. Altera customers are advised to obtain the latest version of device specifications before relying on any published information and before placing orders for products or services.



## Chapter 1. Overview

Introduction .....	1-1
General Description .....	1-1
Development Board Block Diagram .....	1-4
Handling the Board .....	1-5

## Chapter 2. Board Components

Introduction .....	2-1
Board Overview .....	2-2
Featured Device: Stratix IV GT Device .....	2-5
I/O Resources .....	2-6
Configuration, Status, and Setup Elements .....	2-9
Configuration .....	2-9
Embedded USB-Blaster .....	2-9
Fast Passive Parallel Download .....	2-10
JTAG Programming Header .....	2-11
Status and Setup Elements .....	2-11
Status LEDs .....	2-11
Board Jumpers .....	2-12
Clocks .....	2-14
General User Input/Output .....	2-16
Push Buttons .....	2-16
User LEDs .....	2-17
LCD .....	2-17
DIP Switches .....	2-18
Flash Memory Device .....	2-18
Components and Interfaces .....	2-20
Temperature Measurement .....	2-20
Power Measurement .....	2-22
Ethernet Port .....	2-23
Transceiver Channels .....	2-24
Power .....	2-25
Power Distribution System .....	2-26
Banana Jacks and Fuses .....	2-27

## Appendix A. Board Revision History

Single-Die Flash Version Differences .....	A-1
--	-----

## Additional Information

Document Revision History .....	Info-1
How to Contact Altera .....	Info-1
Typographic Conventions .....	Info-1



## Introduction

The Transceiver Signal Integrity Development Kit, Stratix® IV GT Edition allows you to evaluate the performance the Stratix IV GT transceivers and the low power benefits of the device itself. This document provides the detailed pin-out and component reference information required to create FPGA designs for implementation on the development board.

- For information about setting up the Stratix IV GT transceiver signal integrity development board, and using the included software, refer to the *Transceiver Signal Integrity Development Kit, Stratix IV GT Edition User Guide*.

## General Description

The Stratix IV GT transceiver signal integrity development board provides a hardware platform for evaluating the performance and signal integrity features of the Altera® Stratix IV GT devices. The board features the following major component blocks:

- EP4S100G2F40I1N FPGA
  - 0.95-V core
  - 1517-pin Fineline BGA (FBGA)
- FPGA Configuration
  - MAX® II+Flash Fast Passive Parallel (FPP) configuration
  - Flash storage for two configuration images (factory and user)
  - On-Board USB-Blaster™ using the Quartus® II Programmer
  - JTAG header for external USB-Blaster with the Quartus II Programmer
- On-Board Memory
  - 64-MB synchronous flash

- Status and Setup Elements
  - System reset push button
  - CPU reset push button
  - 4-position spread spectrum clock selection DIP switch
  - Three configuration status LEDs (factory, user, configuration error)
  - USB-Blaster activity LED
  - Ethernet link 10 LED
  - Ethernet link 100 LED
  - Ethernet link 1000 LED
  - Ethernet full duplex LED
  - Ethernet TX activity LED
  - Ethernet RX activity LED
  - Over-Temperature warning LED
  - Power LED
- FPGA Clock Sources
  - FPGA core clock sources
    - 25-MHz/100-MHz/125-MHz/200-MHz selectable spread spectrum clock oscillator
    - 50-MHz clock oscillator
    - SMA connectors for external differential clock input
  - FPGA transceiver clock sources
    - 100-MHz clock oscillator
    - 644.53-MHz clock oscillator
    - 706.25-MHz clock oscillator
    - SMA connectors for external differential clock input
- Clock Outputs and Triggers
  - Two FPGA I/O clock outputs to SMA connectors
  - 100-MHz clock trigger output to SMA connector
  - 644.53-MHz clock trigger output to SMA connector
  - 706.25-MHz clock trigger output to SMA connector

- General User Input/Output
  - 8-position user DIP switch
  - Six user push buttons
  - Hex rotary switch
  - Eight user LEDs
  - 16 character × 2 line LCD
- Components and Interfaces
  - 10/100/1000 Ethernet PHY and RJ-45 jack
  - Transceiver channels
    - Six full-duplex transceiver channels from GXB0 transceiver block brought out to the backplane connectors
    - Four full-duplex transceiver channels from GXB1 transceiver block brought out to the SMA connectors
    - Two channels from GXB2 transceiver block brought out to the SMA connectors. One channel is routed with 15 inches of board trace length on transmit and 5 inches board trace length on receive to simulate the degradation associated with long trace PCB routing
- Power
  - 14-V – 20-V DC input
  - 2.5-mm Barrel Jack for DC power input
  - On/Off slide power switch
  - On-Board power measurement circuitry
- Heat Sink and Fan
  - 40-mm heat sink and 5-V DC fan combo

# Development Board Block Diagram

Figure 1-1 shows the block diagram of the Stratix IV GT transceiver signal integrity board.

Figure 1-1. Stratix IV GT Transceiver Signal Integrity Board Block Diagram

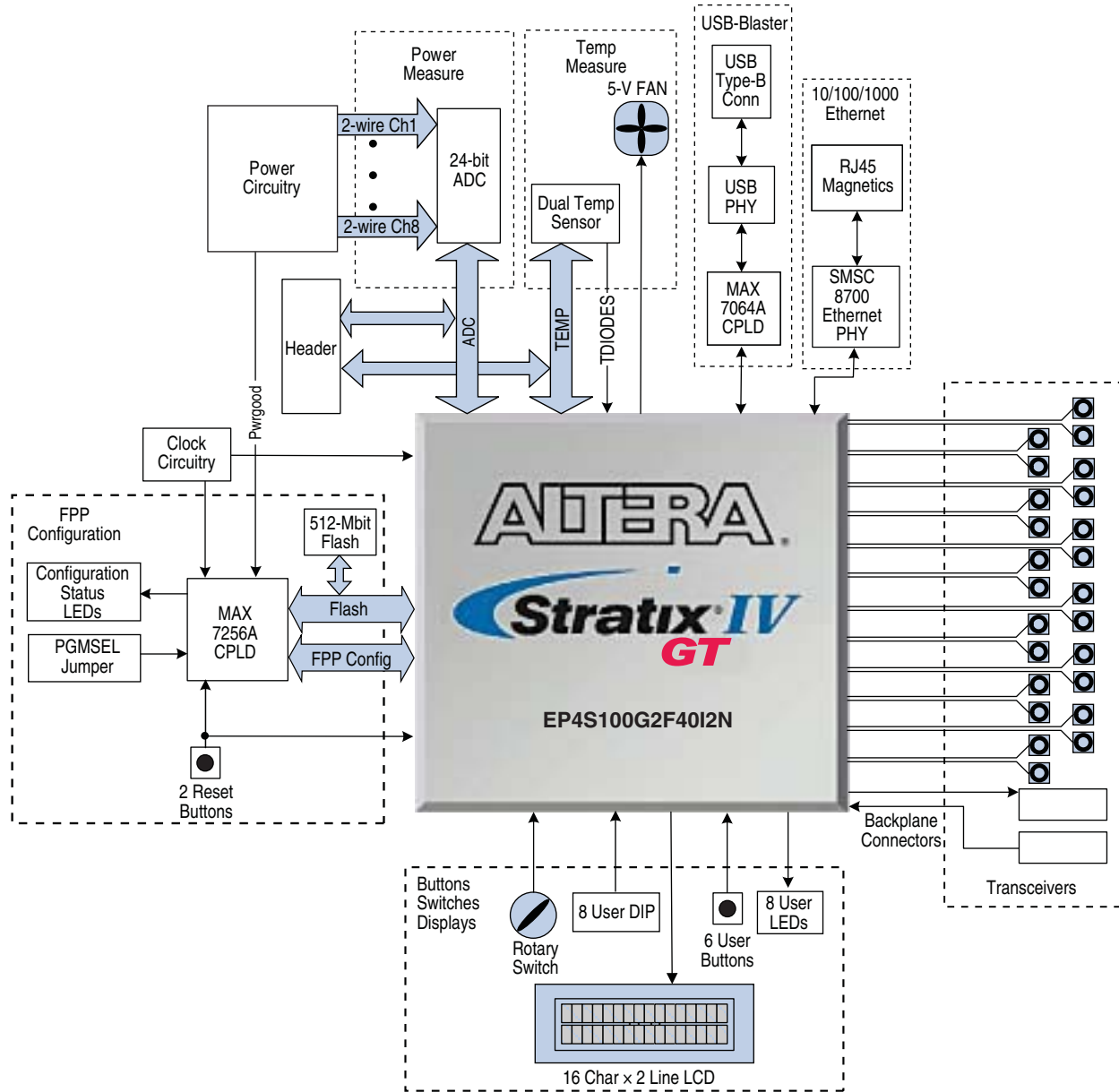

## Handling the Board

When handling the board, it is important to observe the following static discharge precaution:



Without proper anti-static handling, the board can be damaged. Therefore, use anti-static handling precautions when touching the board.

The Stratix IV GT transceiver signal integrity board must be stored between  $-40^{\circ}\text{C}$  and  $100^{\circ}\text{C}$ . The recommended operating temperature is between  $0^{\circ}\text{C}$  and  $55^{\circ}\text{C}$ .



## Introduction

This chapter introduces all the important components on the Stratix IV GT transceiver signal integrity development board. [Figure 2-1](#) illustrates major component locations and [Table 2-1](#) provides a brief description of all features of the board.



A complete set of schematics, a physical layout database, and GERBER files for the development board reside in the Stratix IV GT transceiver signal integrity development kit installation directory.



For information about powering up the board and installing the development kit software, refer to the *Transceiver Signal Integrity Development Kit, Stratix IV GT Edition User Guide*.

This chapter consists of the following sections:

- “Board Overview”
- “Featured Device: Stratix IV GT Device” on page 2-5
- “Configuration, Status, and Setup Elements” on page 2-9
- “General User Input/Output” on page 2-16
- “Flash Memory Device” on page 2-18
- “Components and Interfaces” on page 2-20
- “Power” on page 2-25

# Board Overview

This section provides an overview of the Stratix IV GT transceiver signal integrity development board, including an annotated board image and component descriptions. Figure 2-1 provides an overview of the board features.

**Figure 2-1. Overview of the Stratix IV GT Transceiver Signal Integrity Board Features**

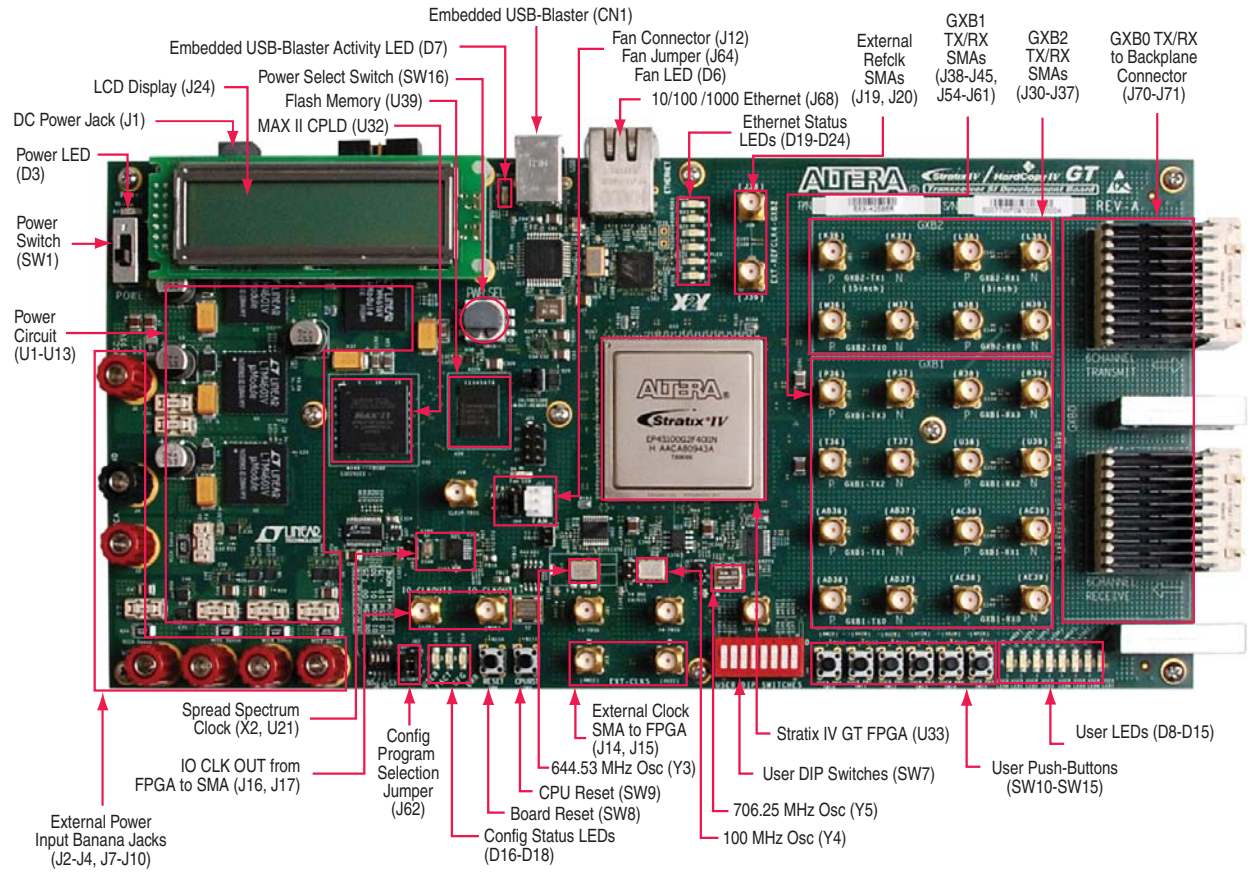

Table 2-1 describes the components and lists their corresponding board references.

**Table 2-1. Stratix IV GT Transceiver Signal Integrity Development Board Components (Part 1 of 4)**

Board Reference	Type	Description
<b>Featured Devices</b>		
U33	EP4S100G2F4011N	Stratix IV GT device in a 1517-pin FBGA package.
<b>Configuration, Status, and Setup Elements</b>		
J28	JTAG programming header	JTAG programming header for connecting an Altera USB-Blaster dongle to program the FPGA and MAX II CPLD devices.
J26	MAX II JTAG configuration jumper	Jumper to bypass the MAX II CPLD from the JTAG programming chain.
J63	JTAG for embedded USB-Blaster MAX II CPLD	JTAG for embedded USB-Blaster MAX II CPLD device programming.

**Table 2–1. Stratix IV GT Transceiver Signal Integrity Development Board Components (Part 2 of 4)**

Board Reference	Type	Description
U32	MAX II CPLD	Altera EPM1270256C3N, MAX II 256-pin CPLD for MAX II+FPP configuration.
D6	Fan LED	Indicates an FPGA over-temperature condition exists and a fan should be attached to the FPGA and running.
D16–D18	Configuration status LEDs	LEDs to indicate the status of FPP configuration.
J62	Configuration program select jumper	Jumper to select the flash configuration image to load upon power-on or reset.
J65	Y3 OSC enable/disable jumper	Jumper to enable or disable the Y3 OSC.
J66	Y4 OSC enable/disable jumper	Jumper to enable or disable the Y4 OSC.
J67	Y5 OSC enable/disable jumper	Jumper to enable or disable the Y5 OSC.
D3	Power LED	Blue LED to indicate board power status.
D7	USB-Blaster LED	Green activity status LED for the embedded USB-Blaster.
D19–D24	Bank of Ethernet LINK and Status LEDs	Ethernet Link, Speed, Full Duplex, Transmit and Receive activity LEDs.
SW16	Power measurement rotary switch	This switch selects 1 of 6 measured FPGA power rails to display on the LCD.
SW2	Spread spectrum configuration DIP switch	DIP switch to set the spread spectrum output clock frequency and down-spread percentages.
J18	Spread spectrum clock trigger	Spread spectrum clock source routed to SMA for triggering purposes.
J21	Y3 OSC clock trigger	Y3 oscillator clock source routed to SMA for triggering purposes.
J22	Y4 OSC clock trigger	Y4 oscillator clock source routed to SMA for triggering purposes.
J23	Y5 OSC clock trigger	Y5 oscillator clock source routed to SMA for triggering purposes.
J14, J15	Differential SMA clock input to FPGA core	SMA for receiving a differential external clock input to the FPGA core.
J19, J20	Differential SMA clock input to FPGA transceiver	SMA for receiving a differential external clock input to the FPGA transceiver.
J16, J17	Differential SMA clock output from FPGA core	SMA for sending a differential clock output from the FPGA core.
<b>Clock Circuitry</b>		
Y2, U20	50-MHz OSC and clock buffer	50-MHz clock to the FPGA and MAX II CPLD.
Y3, U22	644.53-MHz OSC and clock buffer	644.53-MHz clock to the FPGA transceivers.
Y4, U23	100-MHz OSC and clock buffer	100-MHz clock to the FPGA transceivers.
Y5, U24	706.25-MHz OSC and clock buffer	706.25-MHz clock to the FPGA transceivers.
X1	6-MHz XTAL	XTAL for FTDI USB PHY device.
Y1	24-MHz OSC	24-MHz oscillator for embedded USB-Blaster MAX II CPLD.
X3	25-MHz OSC	25-MHz oscillator for Marvell 88E1111 Ethernet PHY device.
X2, U21	25-MHz OSC and spread spectrum clock buffer	25-MHz oscillator and spread spectrum clock buffer circuitry.

**Table 2-1. Stratix IV GT Transceiver Signal Integrity Development Board Components (Part 3 of 4)**

Board Reference	Type	Description
<b>General User Input and Output</b>		
SW7	Bank of 8 user DIP switches	User DIP switches.
SW10–SW15	Bank of 6 user push buttons	User push buttons switches.
D8–D15	Bank of 8 user LEDs	User LEDs.
J25	General purpose user I/O header field	Four user I/Os brought out to a 0.1 inch header field.
J24	LCD interface header	Header for interfacing a 16 character × 2 line LCD.
<b>Memory Devices</b>		
U39	Flash memory	Numonyx 48F4400P0VB00, 512-Mb flash memory.
<b>Components and Interfaces</b>		
CN1	USB Type-B connector	USB interface for embedded USB-Blaster.
U17	MAX II CPLD	Altera EPM7064AETC44 MAX II CPLD device for embedded USB-Blaster circuitry.
J68	Ethernet RJ45 jack	Halo HFJ11-1G02E RJ45 Ethernet jack with integrated magnetic.
U40	10/100/1000 Ethernet PHY	Marvell 88E1111 triple speed Ethernet PHY.
J70	GXB0 transmit channel 0-5	Transceiver GXB0 transmit channel 0-5 connected to a backplane connector.
J71	GXB0 receive channel 0-5	Transceiver GXB0 receive channel 0-5 connected to a backplane connector.
J39, J41	GXB1 transmit channel 0	Transceiver GXB1 transmit channel 0 connected to SMA.
J43, J45	GXB1 transmit channel 1	Transceiver GXB1 transmit channel 1 connected to SMA.
J55, J57	GXB1 transmit channel 2	Transceiver GXB1 transmit channel 2 connected to SMA.
J59, J61	GXB1 transmit channel 3	Transceiver GXB1 transmit channel 3 connected to SMA.
J38, J40	GXB1 receive channel 0	Transceiver GXB1 receive channel 0 connected to SMA.
J42, J44	GXB1 receive channel 1	Transceiver GXB1 receive channel 1 connected to SMA.
J54, J56	GXB1 receive channel 2	Transceiver GXB1 receive channel 2 connected to SMA.
J58, J60	GXB1 receive channel 3	Transceiver GXB1 receive channel 3 connected to SMA.
J34, J36	GXB2 transmit channel 0	Transceiver GXB2 transmit channel 0 connected to SMA.
J30, J32	GXB2 receive channel 0	Transceiver GXB2 receive channel 0 connected to SMA.
J31, J33	GXB2 transmit channel 1	Transceiver GXB2 transmit channel 1 connected to SMA.
J35, J37	GXB2 receive channel 1	Transceiver GXB2 receive channel 1 connected to SMA.
J12	Fan power connector	Power connector for 5-V DC fan sink.
J64	Fan control jumper	Jumper to select whether the fan is always on or automatically controlled by the FPGA.
SW8	Reset push button	Board reset push button.
SW9	CPU reset push button	CPU reset push button.
<b>Power</b>		
J1	Power Input Jack	14-V – 20-V DC female input power jack. Accepts 2.5-mm male center-positive barrel from supplied 16-V DC power supply.
SW1	Power switch	Switch to power on/off the board.

**Table 2-1. Stratix IV GT Transceiver Signal Integrity Development Board Components (Part 4 of 4)**

Board Reference	Type	Description
J2	0.95-V banana jack	Banana jack for supplying external 0.95-V $V_{CC}$ power to the FPGA. Fuses F1 and F2 must be removed prior to supplying external power to this banana jack.
J3	VCCA banana jack	Banana jack for supplying external $V_{CCA}$ power to the FPGA. Fuse F3 must be removed prior to supplying external power to this banana jack.
J7	VCCR banana jack	Banana jack for supplying external $V_{CCR}$ power to the FPGA. Fuse F4 must be removed prior to supplying external power to this banana jack.
J8	VCCT banana jack	Banana jack for supplying external $V_{CCT}$ power to the FPGA. Fuse F5 must be removed prior to supplying external power to this banana jack.
J9	VCCH banana jack	Banana jack for supplying external $V_{CCH}$ power to the FPGA. Fuse F6 must be removed prior to supplying external power to this banana jack.
J10	VCCL banana jack	Banana jack for supplying external $V_{CCL}$ power to the FPGA. Fuse F7 must be removed prior to supplying external power to this banana jack.
J4	GND banana jack	Banana jack connected to GND of the board.
F1, F2	10A fuse	Fuses for 0.95-V $V_{CC}$ core of the FPGA. These fuses must be removed when an external power is applied to this banana jack.
F3	2A fuse	Fuse for $V_{CCA}$ power of the FPGA. This fuse must be removed when an external power is applied to this banana jack.
F6	5A fuse	Fuse for $V_{CCH}$ power of the FPGA. This fuse must be removed when an external power is applied to this banana jack.
F7	2A fuse	Fuse for $V_{CCL}$ power of the FPGA. This fuse must be removed when an external power is applied to this banana jack.
F4	2A fuse	Fuse for $V_{CCR}$ power of the FPGA. This fuse must be removed when an external power is applied to this banana jack.
F5	2A fuse	Fuse for $V_{CCT}$ power of the FPGA. This fuse must be removed when an external power is applied to this banana jack.
U14	Power measurement ADC	Linear Technology LTC2418CGN 24-bit delta-sigma analog to digital converter (ADC).
R3	0.001- $\Omega$ Rsense	Sense resistor for measuring FPGA $V_{CC}$ core power.
R11	0.009- $\Omega$ Rsense	Sense resistor for measuring FPGA $V_{CCA}$ power.
R24	0.009- $\Omega$ Rsense	Sense resistor for measuring FPGA $V_{CCH}$ power.
R25	0.009- $\Omega$ Rsense	Sense resistor for measuring FPGA $V_{CCL}$ power.
R20	0.009- $\Omega$ Rsense	Sense resistor for measuring FPGA $V_{CCR}$ power.
R21	0.009- $\Omega$ Rsense	Sense resistor for measuring FPGA $V_{CCT}$ power.

## Featured Device: Stratix IV GT Device

The Stratix IV GT transceiver signal integrity development board features the EP4S100G2F40I1N Stratix IV FPGA device (U33) in a 1517-pin FBGA package.



For more information about the Stratix IV GT devices, refer to the *Stratix IV Device Handbook*.

Table 2-2 lists the features of the Stratix IV GT EP4S100G2F40I1N device.

**Table 2-2. Stratix IV GT Device EP4S100G2F40I1N Features**

ALMs	Equivalent LEs	M9K RAM Blocks	M144K Blocks	Total RAM bits	DSP Blocks	18-bit × 18-bit Multipliers	PLLs	Maximum User I/O pins	Package Type
91,200	228,000	1,235	22	17,133	161	1,288	8	636	1517-pin FBGA

Table 2-3 lists the Stratix IV GT component reference and manufacturing information.

**Table 2-3. Stratix IV GT Device Component Reference and Manufacturing Information**

Board Reference	Description	Manufacturer	Manufacturing Part Number	Manufacturer Website
U33	Stratix IV GT	Altera Corporation	EP4S100G2F40I1N	<a href="http://www.altera.com">www.altera.com</a>

## I/O Resources

Figure 2-2 shows the bank organization and I/O count for the EP4S100G2F40I1N device in the 1517-pin FBGA package.

**Figure 2-2. Stratix IV GT Device I/O Bank Diagram (1)**

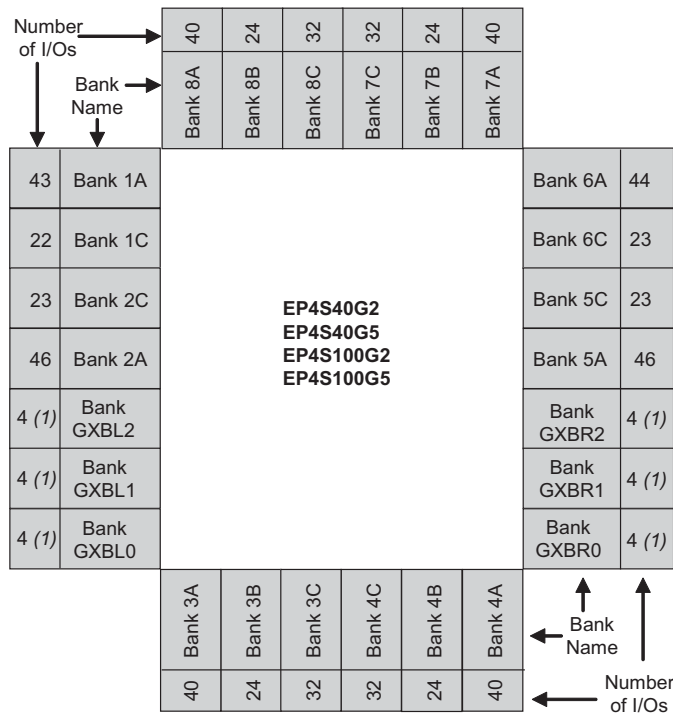

**Note to Figure 2-2:**

(1) There are two additional PMA-only transceiver channels in each transceiver bank.

Table 2–4 summarizes the FPGA I/O usage by function on the Stratix IV GT transceiver signal integrity development board. I/O direction is with respect to the FPGA.

**Table 2–4. Stratix IV GT I/O Usage Summary (Part 1 of 3)**

Function	I/O Type	I/O Count	Description
<b>FPGA Transceiver Clocks</b>			
100-MHz Diff Clock	LVDS input	2	Diff REFCLK Input
644.25-MHz Diff Clock	LVDS input	2	Diff REFCLK Input
706.53-MHz Diff Clock	LVDS input	2	Diff REFCLK Input
SMA Diff Clock Inputs	LVDS input	2	Diff REFCLK Input
<b>FPGA Global Clocks</b>			
50-MHz Clock	2.5-V CMOS input	1	Global Clock Input
Spread Spectrum Clock	LVDS input	2	Diff Global Clock
SMA Diff Clock Input	LVDS input	2	Diff Global Clock
SMA Diff I/O or Clock Output	—	2	Diff Global I/O or Clock Output
<b>Temperature Monitor</b>			
Temp Sense Diodes	Analog	2	Stratix IV GT Internal Sense Diode
<b>Power Measure</b>			
ADC Interface	2.5-V CMOS	5	8 Diff Channel 24-bit A/D Converter
<b>Temp Measure</b>			
MAX1619 Interface	2.5-V CMOS	4	Die Temp Sense
<b>EEPROM</b>			
EEP_CSn	2.5-V CMOS output	1	EEPROM Chip Select
<b>Fan</b>			
FAN_On	2.5-V CMOS output	1	Fan Control
FAN_LED	2.5-V CMOS output	1	Fan LED
<b>USB-Blaster</b>			
JTAG USB-Blaster or JTAG header	2.5-V CMOS	4	Built-in USB-Blaster or JTAG 0.1-mm header for Debug
<b>FPP Configuration</b>			
FPGA Dclk	2.5-V CMOS input	1	FPP Dclk
FPGA D[7:0]	2.5-V CMOS input	8	FPP Data
MSEL [2:0]	2.5-V CMOS input	3	Dedicated Configuration Pins
NCONFIG	2.5-V CMOS input	1	Dedicated Configuration Pins
NSTATUS	2.5-V CMOS inout	1	Dedicated Configuration Pins
NCE	2.5-V CMOS input	1	Dedicated Configuration Pins
CONFIG_DONE	2.5-V CMOS inout	1	Dedicated Configuration Pins
INIT_DONE	2.5-V CMOS output	1	Dedicated Configuration Pins
PGM[2:0]	2.5-V CMOS output	3	Configuration Program Select Pins

Table 2-4. Stratix IV GT I/O Usage Summary (Part 2 of 3)

Function	I/O Type	I/O Count	Description
<b>Flash Memory</b>			
ADDR[25:0]	2.5-V CMOS output	26	Flash Address Bus
DATA[15:0]	2.5-V CMOS inout	16	Flash Data Bus
FLASH_CEn	2.5-V CMOS output	1	Flash Chip Enable
FLASH_OEn	2.5-V CMOS output	1	Flash Read Strobe
FLASH_WEn	2.5-V CMOS output	1	Flash Write Strobe
FLASH_BSYn	2.5-V CMOS input	1	Flash Busy
FLASH_CLK	2.5-V CMOS output	1	Flash Clock
FLASH_RSTn	2.5-V CMOS output	1	Flash Reset
FLASH_ADVn	2.5-V CMOS output	1	Flash Address Valid
FLASH_WPn	2.5-V CMOS output	1	Flash Write Protect
<b>Resets</b>			
CPU_RESETh	2.5-V CMOS input	1	Nios® II CPU Reset
S4GT_RESETh	2.5-V CMOS input	1	S4GT General FPGA Reset
<b>Switches, Buttons, LEDES</b>			
User Push Buttons	2.5-V CMOS input	6	6 User Push buttons
User DIP Switches	2.5-V CMOS input	8	8 User DIP Switches
User LEDES	2.5-V CMOS output	8	8 User LEDES (Green)
HEX Rotary Switch	2.5-V CMOS input	4	16 Position Rotary Switch
User I/Os	2.5-V CMOS inout	4	4 User I/O pins to header field
<b>LCD</b>			
16 Character × 2 Line LCD	2.5-V CMOS	11	LCD
<b>Ethernet</b>			
TXD[3:0]	2.5-V CMOS output	4	Ethernet Transmit RGMII Data Bus
TXEN	2.5-V CMOS output	1	Ethernet Transmit Enable
GTCLK	2.5-V CMOS output	1	Ethernet Transmit Clock
RXD[3:0]	2.5-V CMOS input	4	Ethernet Receive RGMII Data Bus
RXDV	2.5-V CMOS input	1	Receive Data Valid
RXCLK	2.5-V CMOS input	1	Receive Clock
MDC	2.5-V CMOS input	1	Ethernet MII Clock
MDIO	2.5-V CMOS inout	1	Ethernet MII Data
ENET_SGMII_TXP/N	LVDS output	2	Ethernet SGMII Transmit Data Positive/Negative
ENET_SGMII_RXP/N	LVDS input	2	Ethernet SGMII Receive Data Positive/Negative
<b>Transceivers</b>			
GXB0 Transmit Channel	Transceiver channel	12	Six matched length GXB0 transmit channels routed to a backplane connector J70.
GXB0 Receive Channel	Transceiver channel	12	Six matched length GXB0 receive channels routed to a backplane connector J71.

**Table 2-4. Stratix IV GT I/O Usage Summary (Part 3 of 3)**

Function	I/O Type	I/O Count	Description
GXB2 Short Transmit Channel	Transceiver channel	2	Short transmit trace length (11.3G)
GXB2 Short Receive Channel	Transceiver channel	2	Short receive trace length (11.3G)
GXB2 Long Transmit Channel	Transceiver channel	2	15 inches trace length (11.3G)
GXB2 Long Receive Channel	Transceiver channel	2	5 inches trace length (11.3G)
GXB1 Four Full-Duplex Transceiver Channels (One entire block, excluding two clock multiplier unit (CMU) channels)	Transceiver channel	16	Four full-duplex channels from one entire transceiver block (excluding two CMU channels)
<b>Spares</b>			
Spare[7:0]	2.5-V CMOS inout	8	Spare signals to the MAX II CPLD
<b>Total Device I/O: 220</b>			
<b>Available Stratix IV GT I/O: 636</b>			

## Configuration, Status, and Setup Elements

This section describes the board's configuration, status, and setup elements.

### Configuration

The Stratix IV GT transceiver signal integrity development board supports three configuration methods:

- Embedded USB-Blaster is the default method for configuring the FPGA at any time using the Quartus II Programmer in JTAG mode with the supplied USB cable.
- MAX II+Flash FPP download for configuring the FPGA using stored images from flash on either power-up or pressing the reset (SW8) push button.
- JTAG programming header (J28) for configuring the FPGA using an external USB-Blaster (not supplied) and the Quartus II Programmer.

The following sections describe each of these methods.

#### Embedded USB-Blaster

The embedded USB-Blaster is implemented using a Type-B USB connector (CN1), a Future Technologies FT245BL USB PHY device (U16), and an Altera EPM7064 MAX II CPLD (U17). This allows the configuration of the FPGA using a USB cable directly connected between the USB port on the board (CN1) and a USB port of a PC running the Quartus II software.

A green USB-Blaster LED (D7) is also provided to indicate USB-Blaster activity. The embedded USB-Blaster is automatically disabled when an external USB-Blaster connects to the JTAG chain at header J28. Figure 2-3 shows the block diagram for the embedded USB-Blaster.

**Figure 2-3. Embedded USB-Blaster**

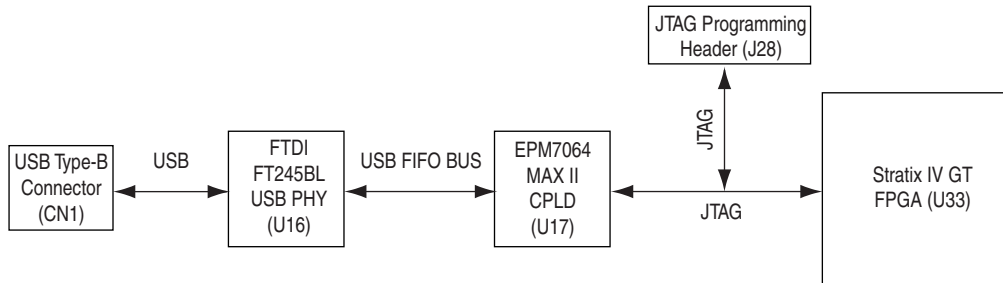

### Fast Passive Parallel Download

Figure 2-4 shows the block diagram for the MAX II+Flash FPP configuration. This method is used for automatic configuration of the FPGA with the configuration programming image stored in the flash memory. The FPP download controller is implemented within an Altera EPM1270F256C3N MAX II CPLD (U32). This controller, together with the Numonyx PC28F512P30BF 512-Mb CFI NOR-type flash memory (U39), performs the FPP configuration upon board power-up or reset. The CPLD shares the flash interface with the FPGA. The configuration program select jumper, PGMSEL, (J62) selects between two Programmer Object Files (.pof)—factory .pof or user .pof file stored in the flash. The FPP controller uses the Altera Parallel Flash Loader (PFL) megafunction to configure the FPGA by reading data from the flash and converting it to FPP format. This data is written to the FPGA's dedicated configuration pins during configuration. The configuration mode select signals, MSEL [2:0], are pulled to [0, 0, 0] on the board for FPP mode configuration. Three green configuration status LEDs (D16–D18) indicate the status of the FPP configuration.

**Figure 2-4. MAX II+Flash FPP Configuration**

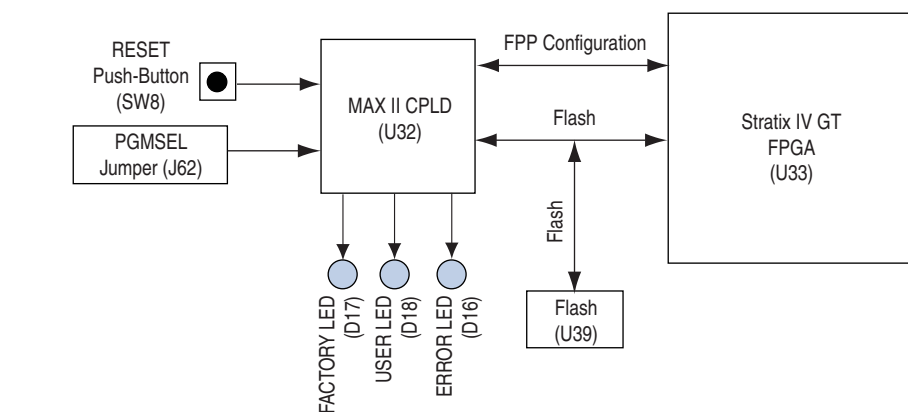

## JTAG Programming Header

Figure 2-5 shows the schematic connections for the dedicated JTAG programming header (J28). This header provides another method for configuring the FPGA (U33) using an Altera USB-Blaster with the Quartus II Programmer running on a PC. The MAX II JTAG configuration jumper (J26) allows the MAX II CPLD device to be removed from the JTAG chain so that the FPGA is the only device on the JTAG chain.

Figure 2-5. JTAG Programming Header

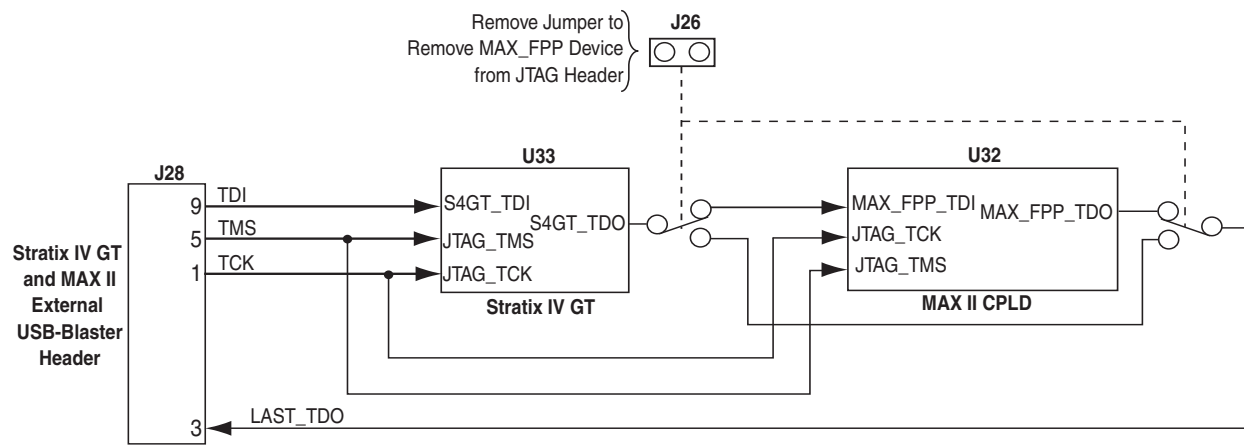

## Status and Setup Elements

The development board includes board-specific status LEDs, jumpers, and switches for enabling and configuring various features on the board, as well as a 16 character × 2 line LCD for displaying board power and temperature measurements. This section describes the status and setup elements.

### Status LEDs

Table 2-5 lists the LED board references, names, and functional descriptions.

Table 2-5. Board-Specific LEDs (Part 1 of 2)

Board Reference	LED Name	Description
D3	POWER	Blue LED. Illuminates when the board power switch (SW1) is on. (Requires 14–20 V input to DC input jack J1)
D6	FAN	Amber LED. Illuminates to indicate an FPGA over-temperature condition. A fan sink must be attached to the FPGA and running to prevent overheating.
D7	BLASTER	Green LED. Blinks to indicate the embedded USB-Blaster activity.
D16	ERROR	Red LED. Illuminates when a configuration error has occurred.
D17	FACTORY	Green LED. Illuminates when the factory POF image is successfully programmed into the FPGA.
D18	USER	Green LED. Illuminates when the user POF image is successfully programmed into the FPGA.
D19	TX	Green LED. Blinks to indicate Ethernet transmit activity.
D20	RX	Green LED. Blinks to indicate Ethernet receive activity.

**Table 2-5. Board-Specific LEDs (Part 2 of 2)**

Board Reference	LED Name	Description
D21	DUPLEX	Green LED. Illuminates to indicate Ethernet full duplex status.
D22	1000	Green LED. Illuminates to indicate Ethernet linked at 1000 Mbps.
D23	100	Green LED. Illuminates to indicate Ethernet linked at 100 Mbps.
D24	10	Green LED. Illuminates to indicate Ethernet linked at 10 Mbps.

Table 2-6 shows the surface mount LEDs which indicate various status of the board.

**Table 2-6. Status LEDs**

Board Reference	Description	Schematic Signal Name	I/O Standard	Stratix IV GT Device Pin Number	Other Connections
D3	Power LED	5V	—	—	—
D17	FACTORY LED	FACTORY_IMAGE	2.5-V CMOS	—	U32 pin R8
D18	USER LED	USER_IMAGE		—	U32 pin R7
D16	ERROR LED	CONFIG_ERR		—	U32 pin R9
D19	Ethernet transmit activity LED	ENET_LED_TX		—	U40 pin 68
D20	Ethernet receive activity LED	ENET_LED_RX		—	U40 pin 69
D21	Ethernet Full-Duplex LED	ENET_LED_DUPLEX		—	U40 pin 70
D22	Ethernet 1000-MB Link LED	ENET_LED_LINK1000		—	U40 pin 73
D23	Ethernet 100-MB Link LED	ENET_LED_LINK100		—	U40 pin 74
D24	Ethernet 100-MB Link LED	ENET_LED_LINK10	—	U40 pin 76	
D6	Over-Temperature LED	FAN_LED	2.5-V CMOS	U33 pin F14	—
D7	USB-Blaster activity LED	USB_LED	3.3-V CMOS	—	U17 pin 8

## Board Jumpers

Table 2-7 lists the board jumper references, names, and functional descriptions.

**Table 2-7. Board Jumpers (Part 1 of 2)**

Board Reference	Jumper Name	Description
J26	MAXII BYPASS	When a jumper is installed, the MAX II CPLD device (U32) is included in the JTAG programming chain. When a jumper is removed, the MAX II CPLD device (U32) is removed from the JTAG programming chain.
J62	PGMSEL	When a jumper is installed on pins 1-2, FPP configuration loads the user POF image from flash. When a jumper is installed on pins 2-3, FPP configuration loads the factory POF image from flash.
J64	FAN	When a jumper is installed on pins 1-2, the fan is automatically controlled by the FPGA. When a jumper is installed on pins 2-3, the fan is always on.

**Table 2-7. Board Jumpers (Part 2 of 2)**

Board Reference	Jumper Name	Description
J65	Y3 OSC	When a jumper is installed, Y3 oscillator is disabled.
	EN/DIS	When a jumper is removed, Y3 oscillator is enabled and running.
J66	Y4 OSC	When a jumper is installed, Y4 oscillator is disabled.
	EN/DIS	When a jumper is removed, Y4 oscillator is enabled and running.
J67	Y5 OSC	When a jumper is installed, Y5 oscillator is disabled.
	EN/DIS	When a jumper is removed, Y5 oscillator is enabled and running.

There is a spread spectrum configuration DIP switch (SW2) for configuring the spread spectrum clock device (U21). Table 2-8 lists the connection of the spread spectrum configuration DIP switch (SW2).

**Table 2-8. Spread Spectrum Configuration DIP Switch Pin-Out (SW2)**

Board Reference	Description	Schematic Signal Name	I/O Standard	Stratix IV GT Device Pin Name	Other Connections
SW2 pin 1 (S0)	Spread spectrum clock configuration DIP switch. When the switch is in the open position, a logic 1 is selected. When the switch is in the closed position, a logic 0 is selected.	S0	2.5-V CMOS	—	U21 pin 1
SW2 pin 2 (S1)		S1		—	U21 pin 2
SW2 pin 3 (S2)		SS0		—	U21 pin 3
SW2 pin 4 (S3)		SS1		—	U21 pin 8

Table 2-9 summarizes the functionality of the spread spectrum configuration DIP switch (SW2).

**Table 2-9. Spread Spectrum Configuration DIP Switch (SW2) Configuration**

S1	S0	Clock Frequency	S3	S2	Spread Spectrum %
0	0	25 MHz	0	0	Center ±25
0	1	100 MHz	0	1	Down -0.50
1	0	125 MHz	1	0	Down -0.75
1	1	200 MHz	1	1	No spread spectrum

## Clocks

Clocking for the Stratix IV GT transceiver signal integrity board is provided separately for both the FPGA core and transceivers. The core clocks include a dedicated 50-MHz clock, a spread spectrum clock capable of producing either 25-MHz, 100-MHz, 125-MHz, or 200-MHz clock, and a pair of SMA connectors to receive a differential external clock. The dedicated transceiver clocks include a 100-MHz, 644.25-MHz, and a 706.53-MHz clock oscillator source. The 706.53-MHz clock oscillator is an I<sup>2</sup>C programmable clock oscillator device from Silicon Labs that provides any custom frequency to the transceivers. Additionally, for further flexibility, the transceivers can receive a differential clock from an external source through a pair of SMA connectors.

Figure 2-6 shows the Stratix IV GT transceiver signal integrity development board clocking diagram.

**Figure 2-6. Stratix IV GT Transceiver Signal Integrity Board Clocking Diagram**

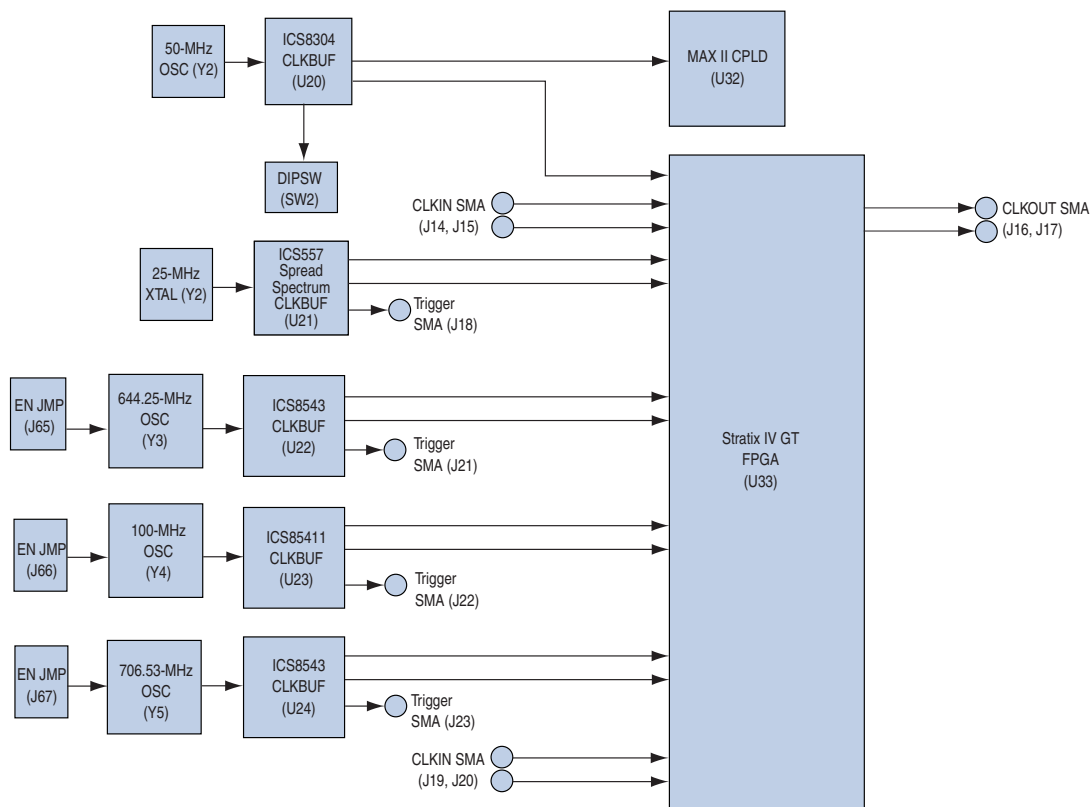

Table 2-10 shows the clock distribution for the Stratix IV GT transceiver signal integrity development board.

**Table 2-10. Stratix IV GT Transceiver Signal Integrity Board Clock Distribution**

Frequency	Signal Name	Signal Originates From	Signal Propagates To
50 MHz	MAXII_50M_CLK	U20 pin 8	U32 pin H5
	S4GT_50M_CLK4P	U20 pin 7	U33 pin AR22
User Input	S4GT_EXT_CLK5P	SMA J14	U33 pin AV22
	S4GT_EXT_CLK5N	SMA J15	U33 pin AW22
User Defined	IO_CLKOUT1	U33 pin M20	SMA J16
User Defined	IO_CLKOUT2	U33 pin L20	SMA J17
25 MHz, 100 MHz, 125 MHz, 200 MHz (Y2) (Frequencies set by switch SW2)	S4GT_CLK1P	U21 pin 15	U33 pin K34
	S4GT_CLK1N	U21 pin 14	U33 pin J34
User Input	EXT_REFCLK4P_GXB2	SMA J19	U33 pin J38
	EXT_REFCLK4N_GXB2	SMA J20	U33 pin J39
644.53 MHz (Y3)	644.53M_REFCLK2P_GXB1	U22 pin 20	U33 pin AA38
	644.53M_REFCLK2N_GXB1	U22 pin 19	U33 pin AA39
706.25 MHz (Y5)	706.25M_REFCLK3P_GXB1	U24 pin 1	U33 pin W38
	706.25M_REFCLK3N_GXB1	U24 pin 2	U33 pin W39
100 MHz (Y4)	100M_REFCLK5P_GXB2	U23 pin 1	U33 pin G38
	100M_REFCLK5N_GXB2	U23 pin 2	U33 pin G39
25 MHz, 100 MHz, 125 MHz, 200 MHz	X2 Trigger	U21 pin 11	SMA J18
644.53 MHz (Y3)	Y3 Trigger	U22 pin 12	SMA J21
100 MHz (Y4)	Y4 Trigger	U23 pin 3	SMA J22
706.25 MHz (Y5)	Y5 Trigger	U24 pin 3	SMA J23

## General User Input/Output

This section describes the user I/O interface to the FPGA including the push buttons, user and status LEDs, LCD, and user DIP, rotary, and slide switches. Table 2-11 lists the component references and the manufacturing information.

**Table 2-11. Component Reference Input and Output Devices**

Board Reference	Device Description	Manufacturer	Manufacturer Part Number	Manufacturer Website
SW8–SW15	Push buttons	Panasonic Corporation	EVQPAC07K	<a href="http://www.panasonic.com">www.panasonic.com</a>
D7–D15, D17–D24	Green LEDs	Lumex Inc.	SML-LX1206GC-TR	<a href="http://www.lumex.com">www.lumex.com</a>
D16	Red LED	Lumex Inc.	SML-LX1206IC-TR	<a href="http://www.lumex.com">www.lumex.com</a>
D6	Amber LED	Lite-on Technology Corporation	LTST-C150KYKT	<a href="http://www.liteon.com">www.liteon.com</a>
D3	Blue LED	Lumex Inc.	SML-LX1206USBC-TR	<a href="http://www.lumex.com">www.lumex.com</a>
LCD	LCD	Lumex Inc.	LCM-S01602DSR/C	<a href="http://www.lumex.com">www.lumex.com</a>
SW7	DIP switch	Grayhill Corporation	76SB08ST	<a href="http://www.grayhill.com">www.grayhill.com</a>
SW2	Mini-DIP switch	C&K Components / ITT Industries	TDA04H0SB1	<a href="http://www.ittcannon.com">www.ittcannon.com</a>
SW16	Rotary switch	Grayhill Corporation	94HCB16WT	<a href="http://www.grayhill.com">www.grayhill.com</a>
SW1	Slide switch	E-switch Inc.	EG2201A	<a href="http://www.e-switch.com">www.e-switch.com</a>

### Push Buttons

The board has eight push buttons for user-defined logic input. Each push-button when pressed drives logic low and when released returns to driving logic high. Table 2-12 summarizes the push buttons signal name and function.

**Table 2-12. Push Button Signal Names and Functions**

Board Reference	Description	Schematic Signal Name	I/O Standard	Stratix IV GT Device Pin Number	Other Connections
SW10	General purpose user push-button switches. These switches are not debounced.	USR_PB0	2.5-V CMOS	U33 pin AW28	10-k $\Omega$ pull-up resistor to 2.5 V
SW11		USR_PB1		U33 pin AV28	
SW12		USR_PB2		U33 pin AU28	
SW13		USR_PB3		U33 pin AT28	
SW14		USR_PB4		U33 pin AR28	
SW15		USR_PB5		U33 pin AP28	
SW8	Board reset. This switch is not debounced.	RESETn		—	U32 pin T2
SW9	CPU reset. This switch is not debounced.	CPURSTn		U33 pin AW18	10-k $\Omega$ pull-up resistor to 2.5 V

## User LEDs

A bank of eight green, surface mount LEDs (SM1206 type) are provided for general purpose use. The cathodes of these LEDs each connects to an FPGA I/O pin while the anodes are pulled to 2.5 V through a current limiting resistor. Driving the corresponding FPGA I/O pin low illuminates the LED. Driving the pin high turns the LED off. Table 2-13 lists the assignment for each user LED.

**Table 2-13. User LED Pin-Out (Green)**

Board Reference	Description	Schematic Signal Name	I/O Standard	Stratix IV GT Device Pin Number	Other Connections
D8	General purpose green surface mount (type 1206) User LEDs. Driving a logic 0 on the I/O port turns the LED ON. Driving a logic 1 on the I/O port turns the LED OFF.	USR_LED0	2.5-V CMOS	U33 pin AW29	160 $\Omega$ to 2.5 V
D9		USR_LED1		U33 pin AV29	160 $\Omega$ to 2.5 V
D10		USR_LED2		U33 pin AU29	160 $\Omega$ to 2.5 V
D11		USR_LED3		U33 pin AT29	160 $\Omega$ to 2.5 V
D12		USR_LED4		U33 pin AW30	160 $\Omega$ to 2.5 V
D13		USR_LED5		U33 pin AT30	160 $\Omega$ to 2.5 V
D14		USR_LED6		U33 pin AP30	160 $\Omega$ to 2.5 V
D15		USR_LED7		U33 pin AN30	160 $\Omega$ to 2.5 V

## LCD

The development board includes a 16 character  $\times$  2 line LCD. The display connects directly to the FPGA device. Table 2-14 lists the LCD pin assignments.

**Table 2-14. Seven-Segment Display Pin-Out**

Board Reference	Description	Schematic Signal Name	I/O Standard	Stratix IV GT Device Pin Name	Other Connections
LCD	LCD DATA 0	LCD_DATA0	2.5-V CMOS	U33 pin B17	J24 pin 7
LCD	LCD DATA 1	LCD_DATA1		U33 pin B19	J24 pin 8
LCD	LCD DATA 2	LCD_DATA2		U33 pin D21	J24 pin 9
LCD	LCD DATA 3	LCD_DATA3		U33 pin D22	J24 pin 10
LCD	LCD DATA 4	LCD_DATA4		U33 pin D23	J24 pin 11
LCD	LCD DATA 5	LCD_DATA5		U33 pin E22	J24 pin 12
LCD	LCD DATA 6	LCD_DATA6		U33 pin E23	J24 pin 13
LCD	LCD DATA 7	LCD_DATA7		U33 pin F23	J24 pin 14
LCD	LCD enable signal	LCD_EN		U33 pin C22	J24 pin 6
LCD	LCD data/control signal	LCD_D_Cn		U33 pin A18	J24 pin 4
LCD	LCD write enable strobe	LCD_Wen		U33 pin A17	J24 pin 5

## DIP Switches

The user DIP switch is for reference design functions and general purpose use. This switch connects to the FPGA device I/O pins. Table 2-15 summarizes the function and connections of the user DIP switch (SW7).

**Table 2-15. User DIP Switch Pin-Out (SW7)**

Board Reference	Description	Schematic Signal Name	I/O Standard	Stratix IV GT Device Pin Name	Other Connections
SW7 pin 1	User DIP switch connected to FPGA device. When the switch is in the open position, a logic 1 is selected. When the switch is in the closed position, a logic 0 is selected.	USR_DIP0	2.5-V CMOS	U33 pin AW27	10-kΩ pull-up resistor to 2.5 V
SW7 pin 2		USR_DIP1		U33 pin AU27	
SW7 pin 3		USR_DIP2		U33 pin AT27	
SW7 pin 4		USR_DIP3		U33 pin AP27	
SW7 pin 5		USR_DIP4		U33 pin AN27	
SW7 pin 6		USR_DIP5		U33 pin AP26	
SW7 pin 7		USR_DIP6		U33 pin AN26	
SW7 pin 8		USR_DIP7		U33 pin AM26	

## Flash Memory Device

The board features a Numonyx PC28F512P30BF 512-Mb CFI-compliant NOR-type flash memory device. This device stores configuration files for the FPGA. Both the MAX II CPLD (U32) and FPGA (U33) devices can access the flash. The MAX II access the flash for FPP configuration of the FPGA using the PFL Megafunction. The FPGA access to the flash's user space for embedded NIOS applications. Table 2-16 lists the pin-out information of the flash memory interface to the FPGA. The signal direction is with respect to the FPGA device.

**Table 2-16. Flash Memory Pin-Out (U39) (Part 1 of 2)**

Board Reference	Description	Schematic Signal Name	I/O Standard	Stratix IV GT Device Pin Name	Other Connections
U39 pin A1	Flash Address bus bit 1	F_AD1	2.5-V CMOS	U33 pin AN15	U32 pin M16
U39 pin B1	Flash Address bus bit 2	F_AD2	2.5-V CMOS	U33 pin AM14	U32 pin M15
U39 pin C1	Flash Address bus bit 3	F_AD3	2.5-V CMOS	U33 pin AN14	U32 pin M14
U39 pin D1	Flash Address bus bit 4	F_AD4	2.5-V CMOS	U33 pin AP15	U32 pin N16
U39 pin D2	Flash Address bus bit 5	F_AD5	2.5-V CMOS	U33 pin AP14	U32 pin N15
U39 pin A2	Flash Address bus bit 6	F_AD6	2.5-V CMOS	U33 pin AL15	U32 pin J16
U39 pin C2	Flash Address bus bit 7	F_AD7	2.5-V CMOS	U33 pin AP13	U32 pin N13
U39 pin A3	Flash Address bus bit 8	F_AD8	2.5-V CMOS	U33 pin AN13	U32 pin N14
U39 pin B3	Flash Address bus bit 9	F_AD9	2.5-V CMOS	U33 pin J15	U32 pin C14
U39 pin C3	Flash Address bus bit 10	F_AD10	2.5-V CMOS	U33 pin H13	U32 pin B12
U39 pin D3	Flash Address bus bit 11	F_AD11	2.5-V CMOS	U33 pin M13	U32 pin F15
U39 pin C4	Flash Address bus bit 12	F_AD12	2.5-V CMOS	U33 pin M14	U32 pin F16
U39 pin A5	Flash Address bus bit 13	F_AD13	2.5-V CMOS	U33 pin K15	U32 pin D16

**Table 2-16. Flash Memory Pin-Out (U39) (Part 2 of 2)**

Board Reference	Description	Schematic Signal Name	I/O Standard	Stratix IV GT Device Pin Name	Other Connections
U39 pin B5	Flash Address bus bit 14	F_AD14	2.5-V CMOS	U33 pin G13	U32 pin A11
U39 pin C5	Flash Address bus bit 15	F_AD15	2.5-V CMOS	U33 pin G14	U32 pin A12
U39 pin D7	Flash Address bus bit 16	F_AD16	2.5-V CMOS	U33 pin J12	U32 pin B13
U39 pin D8	Flash Address bus bit 17	F_AD17	2.5-V CMOS	U33 pin L13	U32 pin E15
U39 pin A7	Flash Address bus bit 18	F_AD18	2.5-V CMOS	U33 pin AM13	U32 pin L14
U39 pin B7	Flash Address bus bit 19	F_AD19	2.5-V CMOS	U33 pin AL14	U32 pin J15
U39 pin C7	Flash Address bus bit 20	F_AD20	2.5-V CMOS	U33 pin K13	U32 pin D14
U39 pin C8	Flash Address bus bit 21	F_AD21	2.5-V CMOS	U33 pin AL13	U32 pin K14
U39 pin A8	Flash Address bus bit 22	F_AD22	2.5-V CMOS	U33 pin K14	U32 pin D15
U39 pin G1	Flash Address bus bit 23	F_AD23	2.5-V CMOS	U33 pin H14	U32 pin A13
U39 pin H8	Flash Address bus bit 24	F_AD24	2.5-V CMOS	U33 pin J13	U32 pin B14
U39 pin B6	Flash Address bus bit 25	F_AD25	2.5-V CMOS	U33 pin K12	U32 pin C13
U39 pin F2	Flash Data bus bit 0	F_D0	2.5-V CMOS	U33 pin AK13	U32 pin L15
U39 pin E2	Flash Data bus bit 1	F_D1	2.5-V CMOS	U33 pin AK14	U32 pin L16
U39 pin G3	Flash Data bus bit 2	F_D2	2.5-V CMOS	U33 pin AJ13	U32 pin K15
U39 pin E4	Flash Data bus bit 3	F_D3	2.5-V CMOS	U33 pin AJ14	U32 pin K16
U39 pin E5	Flash Data bus bit 4	F_D4	2.5-V CMOS	U33 pin AH14	U32 pin H16
U39 pin G5	Flash Data bus bit 5	F_D5	2.5-V CMOS	U33 pin AH13	U32 pin H15
U39 pin G6	Flash Data bus bit 6	F_D6	2.5-V CMOS	U33 pin AG15	U32 pin G16
U39 pin H7	Flash Data bus bit 7	F_D7	2.5-V CMOS	U33 pin AG14	U32 pin G15
U39 pin E1	Flash Data bus bit 8	F_D8	2.5-V CMOS	U33 pin AE15	U32 pin M13
U39 pin E3	Flash Data bus bit 9	F_D9	2.5-V CMOS	U33 pin AD15	U32 pin L13
U39 pin F3	Flash Data bus bit 10	F_D10	2.5-V CMOS	U33 pin AF16	U32 pin J13
U39 pin F4	Flash Data bus bit 11	F_D11	2.5-V CMOS	U33 pin AE16	U32 pin H13
U39 pin F5	Flash Data bus bit 12	F_D12	2.5-V CMOS	U33 pin AG18	U32 pin G13
U39 pin H5	Flash Data bus bit 13	F_D13	2.5-V CMOS	U33 pin AE18	U32 pin F13
U39 pin G7	Flash Data bus bit 14	F_D14	2.5-V CMOS	U33 pin AG19	U32 pin F14
U39 pin E7	Flash Data bus bit 15	F_D15	2.5-V CMOS	U33 pin AF19	U32 pin E14
U39 pin E6	Flash Clock	F_CLK	2.5-V CMOS	U33 pin AU14	U32 pin R16
U39 pin D4	Flash Reset	F_RSTn	2.5-V CMOS	U33 pin N15	U32 pin H14
U39 pin B4	Flash Chip Enable	F_CEn	2.5-V CMOS	U33 pin AR13	U32 pin P14
U39 pin F8	Flash Output Enable	F_OEn	2.5-V CMOS	U33 pin AR14	U32 pin P15
U39 pin G8	Flash Write Enable	F_Wen	2.5-V CMOS	U33 pin N13	U32 pin G14
U39 pin F6	Flash Address Valid	F_ADVn	2.5-V CMOS	U33 pin AT13	U32 pin P13
U39 pin C6	Flash Write Protect	F_WPn	2.5-V CMOS	U33 pin AT14	U32 pin T12
U39 pin F7	Flash Busy	F_BSYn	2.5-V CMOS	U33 pin R14	U32 pin J14

Table 2-17 lists the flash memory map storage for two FPGA bitstreams (factory and user) as well as 40 MB of reserved user space for storage of PFL configuration settings, software binaries, and other data relevant to the targeted FPGA design (Nios II applications). For the EP4S100G2F40I1N FPGA device, each FPGA bitstream can be a maximum of 94.54 Mb (less than 12 MB). Hence, the factory and user POF space is set at 12 MB.

**Table 2-17. Flash Memory Map**

Name	Size (MB)	Address
Reserved	40	0x0180.0000 - 0x03FF.FFFF
USER	12	0x00C0.0000 - 0x017F.FFFF
FACTORY	12	0x0000.0000 - 0x00BF.FFFF

Table 2-18 lists the flash memory device component reference and manufacturing information.

**Table 2-18. Flash Memory Device**

Board Reference	Description	Manufacturer	Manufacturing Part Number	Manufacturer Website
U39	512-Mb NOR-type flash	Numonyx	PC28F512P30BF	<a href="http://www.numonyx.com">www.numonyx.com</a>

## Components and Interfaces

This section describes the temperature measurement and power measurement circuitries and the board's communication ports.

### Temperature Measurement

Figure 2-7 shows the block diagram for the temperature measurement circuitry.

**Figure 2-7. Temperature Measurement**

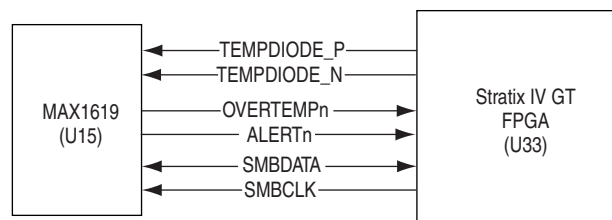

Temperature monitoring for the Stratix IV die is achieved by using a MAX1619 temperature sense device. The MAX1619 connects to the FPGA by a 2-wire SMBus interface. The OVERTEMPn and ALERTn signals from the MAX1619 connect to the FPGA to allow it to immediately sense a temperature fault condition and turn on the attached fan. The FPGA controls the fan based on the OVERTEMPn signal from the MAX1619, or the fan can be set to always ON.

Table 2-19 lists the fan control jumper (J64) which configures the fan.

**Table 2-19. Fan Control Jumper (J64)**

Board Reference	Jumper Name	Description
J64	FAN	When jumper is installed on pins 1-2, the fan is auto-controlled by the FPGA.
		When jumper is installed on pins 2-3, the fan is always on.

An over-temperature orange warning LED (D6) also connects to the FPGA to indicate that an over-temperature condition exists and that a fan should be attached and running. Table 2-20 lists the pin-out of the temperature sense interface to the FPGA.

**Table 2-20. Temperature Sensor Pin-Out**

Board Reference	Description	Schematic Signal Name	I/O Standard	Stratix IV GT Device Pin Number	Other Connections
U15 pin 3	Analog sense DIODE P pin	TEMPDIODE_P	Analog	U33 pin A9	—
U15 pin 4	Analog sense DIODE N pin	TEMPDIODE_N	Analog	U33 pin E11	—
U15 pin 12	SMBus Data pin	S4_SMBDATA	2.5-V CMOS	U33 pin B14	10-k $\Omega$ pull-up resistor to 2.5 V
U15 pin 14	SMBus Clock pin	S4_SMBCLK		U33 pin A14	10-k $\Omega$ pull-up resistor to 2.5 V
U15 pin 9	Over Temperature signal	OVERTEMPn		U33 pin C14	10-k $\Omega$ pull-up resistor to 2.5 V
U15 pin 11	Alert signal	ALERTn		U33 pin D14	10-k $\Omega$ pull-up resistor to 2.5 V

Table 2-21 lists the temperature sensor component reference and manufacturing information.

**Table 2-21. Temperature Sensor Component Reference**

Board Reference	Description	Manufacturer	Manufacturing Part Number	Manufacturer Website
U15	Dual temperature sensor with SMBus interface	Maxim Integrated Products, Inc.	MAX1619MEE+T	<a href="http://www.maxim-ic.com">www.maxim-ic.com</a>

## Power Measurement

Figure 2-8 shows the block diagram for the power measurement circuitry.

**Figure 2-8. Power Measurement Circuit**

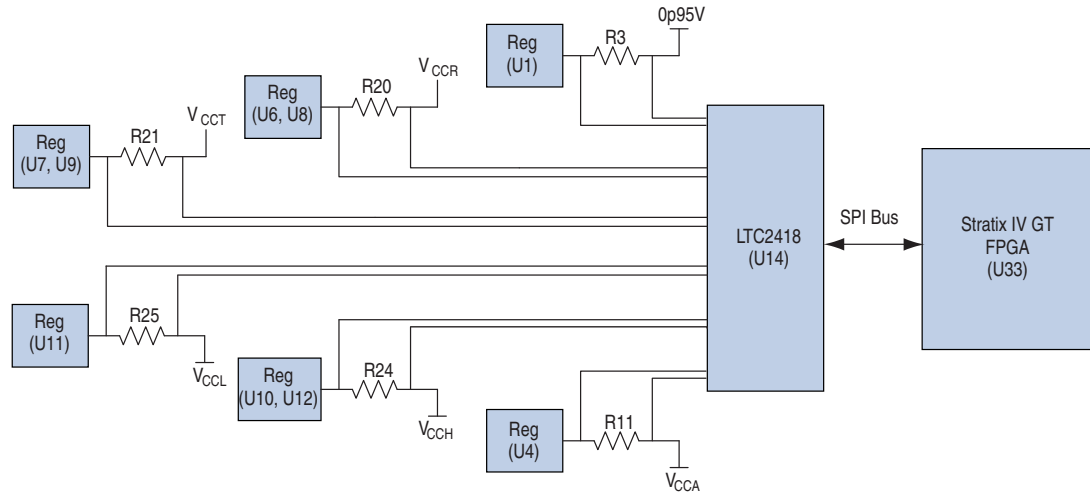

The power measurement is provided for six FPGA power rails (0.95-V  $V_{CC}$  core plus the transceiver power rails— $V_{CCR}$ ,  $V_{CCT}$ ,  $V_{CCL}$ ,  $V_{CCH}$ , and  $V_{CCA}$ ). The power measurement is implemented by a multi-channel differential 24-bit Linear Technology LT2418 (U14) delta-sigma analog-to-digital converter (ADC) and sense resistors to measure the small voltage drop across the resistors. This ADC connects to the FPGA via a serial peripheral interface (SPI) bus. The FPGA handles all power measurement processing and display to the LCD. A rotary switch (SW16) controls the selection of specific power rail to be displayed on the LCD. Table 2-22 lists the power rails being measured along with the value of the sense resistor used for each rail.

**Table 2-22. Power Rail Measurements**

Power Rail	Voltage (V)	Board Reference	$R_{sense}$ ( $\Omega$ )
$V_{CC}$ and $V_{CCHIP}$	0.95	R3	0.001
$V_{CCR}$	1.2	R20	0.009
$V_{CCT}$	1.2	R21	0.009
$V_{CCL}$	1.2	R25	0.009
$V_{CCH}$	1.4	R24	0.009
$V_{CCA}$	3.3	R11	0.009

Table 2-23 lists the SPI Bus pin connections to the FPGA for the power measurement circuitry.

**Table 2-23. Power Measurement Pin-Out**

Board Reference	Description	Schematic Signal Name	I/O Standard	Stratix IV GT Device Pin Number	Other Connections
U14 pin 17	Serial data out	S4_SPI_MISO	2.5-V CMOS	U33 pin C11	—
U14 pin 20	Serial data in	S4_SPI_MOSI	2.5-V CMOS	U33 pin B11	—
U14 pin 18	Serial clock	S4_SPI_SCK	2.5-V CMOS	U33 pin C12	—
U14 pin 16	Chip select	S4_ADC_CS <sub>n</sub>	2.5-V CMOS	U33 pin C13	10-kΩ pull-up resistor to 2.5 V
U14 pin 19	Frequency control	S4_ADC_Fo	2.5-V CMOS	U33 pin A13	—

Table 2-24 lists the ADC component reference and manufacturing information

**Table 2-24. ADC Component Reference**

Board Reference	Description	Manufacturer	Manufacturing Part Number	Manufacturer Website
U14	8-Channel differential 24-bit ADC	Linear Technology	LTC2418CGN#PBF	<a href="http://www.linear.com">www.linear.com</a>

## Ethernet Port

The Stratix IV GT transceiver signal integrity development board incorporates a triple speed 10/100/1000 Base-T Ethernet port. The implementation uses a discrete Ethernet PHY device and RJ45 connector with integrated magnetics connected to the FPGA. Figure 2-9 shows the block diagram of the Ethernet port.

**Figure 2-9. Ethernet Port**

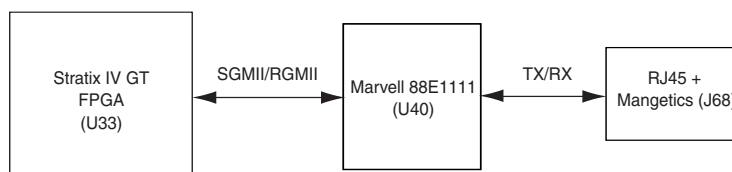

Table 2-25 lists the components used for the Ethernet port and the manufacturing information.

**Table 2-25. Ethernet Component References**

Board Reference	Description	Manufacturer	Manufacturing Part Number	Manufacturer Website
U40	10/100/1000 Base-T Ethernet PHY	Marvell Semiconductor	88E1111-B2-CAA1C000	<a href="http://www.marvell.com">www.marvell.com</a>
J68	RJ45 with integrated magnetics	Halo Electronics	HFJ11-1G02ERL	<a href="http://www.haloelectronics.com">www.haloelectronics.com</a>

Table 2–26 lists the SGMII and RGMII interface pin connection to the FPGA for the Ethernet PHY device.

**Table 2–26. Power Measurement Pin-Out**

Board Reference	Description	Schematic Signal Name	I/O Standard	Stratix IV GT Device Pin Number	Other Connections
U40 pin 11	RGMII Transmit Data 0	TXD0	2.5-V CMOS	U33 pin C29	—
U40 pin 12	RGMII Transmit Data 1	TXD1		U33 pin C30	—
U40 pin 14	RGMII Transmit Data 2	TXD2		U33 pin A27	—
U40 pin 16	RGMII Transmit Data 3	TXD3		U33 pin A29	—
U40 pin 9	RGMII Transmitter Enable	TXEN		U33 pin A31	—
U40 pin 8	RGMII Transmit Clock	GTCLK		U33 pin B29	—
U40 pin 95	RGMII Receive Data 0	RXD0		U33 pin F27	—
U40 pin 92	RGMII Receive Data 1	RXD1		U33 pin F26	—
U40 pin 93	RGMII Receive Data 2	RXD2		U33 pin E29	—
U40 pin 91	RGMII Receive Data 3	RXD3		U33 pin E28	—
U40 pin 94	RGMII Receive Data Valid	RXDV		U33 pin D28	—
U40 pin 2	Receive Clock	RXCLK		U33 pin D29	—
U40 pin 82	SGMII Transmit Data P	ENET_SGMII_TX_P	LVDS output	U33 pin L29	—
U40 pin 81	SGMII Transmit Data N	ENET_SGMII_TX_N		U33 pin K29	—
U40 pin 77	SGMII Receive Data P	ENET_SGMII_RX_P	LVDS input	U33 pin D31	—
U40 pin 75	SGMII Receive Data N	ENET_SGMII_RX_N		U33 pin C31	—

## Transceiver Channels

The Stratix IV GT in the 1517-pin FBGA package incorporates six transceiver blocks (GXB0 left/right, GXB1 left/right, and GXB2 left/right), with up to six transmit and six receive channels per GXB block. For evaluation of these channels, this board offers a total of 12 transceiver channels of the three left GXB blocks to SMA and backplane connectors. Table 2–27 lists the SMA and backplane connector information.

**Table 2–27. SMA Connector Component References**

Board Reference	Description	Manufacturer	Manufacturing Part Number	Manufacturer Website
J30–J61	SMA connector	Lighthouse Technology	LTI-SASF546-P26-X1	<a href="http://www.maxim-ic.com">www.maxim-ic.com</a>
J70–J71	FCI Airmax VS connectors	FCI	10057041-101LF	<a href="http://www.fci.com">www.fci.com</a>

In the left GXB0 block, six transmit and six receive channels are sent to the backplane connectors J70 and J71. In the left GXB1 block, four transmit and four receive channels are sent to SMA connectors J38–J45 and J54–J61. In the left GXB2 block, two transmit and two receive channels are sent to SMA connectors J30–J37.

Table 2–28 summarizes the transceiver channels available on the Stratix IV GT transceiver signal integrity development board.

**Table 2–28. Transceiver Channel Pin-Out**

Board Reference	Description	Schematic Signal Name	I/O Standard	Stratix IV GT Device Pin Number	Other Connections
J70	TX0 from Left GXB0 Block	GXB0_TX0 [p/n]	—	AT36, AT37	J70.F6, J70.E6
J70	TX1 from Left GXB0 Block	GXB0_TX1 [p/n]	—	AP36, AP37	J70.E5, J70.D5
J70	TX2 from Left GXB0 Block	GXB0_TX2 [p/n]	—	AH36, AH37	J70.L4, J70.K4
J70	TX3 from Left GXB0 Block	GXB0_TX3 [p/n]	—	AF36, AF37	J70.K3, J70.J3
J70	TX4 from Left GXB0 Block	GXB0_CMU_TX4 [p/n]	—	AM36, AM37	J70.F4, J70.E4
J70	TX5 from Left GXB0 Block	GXB0_CMU_TX5 [p/n]	—	AK36, AK37	J70.E3, J70.D3
J71	RX0 from Left GXB0 Block	GXB0_RX0 [p/n]	—	AU38, AU39	J71.F6, J71.E6
J71	RX1 from Left GXB0 Block	GXB0_RX1 [p/n]	—	AR38, AR39	J71.E5, J71.D5
J71	RX2 from Left GXB0 Block	GXB0_RX2 [p/n]	—	AJ38, AJ39	J71.L4, J71.K4
J71	RX3 from Left GXB0 Block	GXB0_RX3 [p/n]	—	AG38, AG39	J71.K3, J71.J3
J71	RX4 from Left GXB0 Block	GXB0_CMU_RX4 [p/n]	—	AN38, AN39	J71.F4, J71.E4
J71	RX5 from Left GXB0 Block	GXB0_CMU_RX5 [p/n]	—	AL38, AL39	J71.E3, J71.D3
J39, J41	TX0 from Left GXB1 Block	GXB1_TX0 [p/n]	—	AD36, AD37	—
J38, J40	RX0 from Left GXB1 Block	GXB1_RX0 [p/n]	—	AE38, AE39	—
J43, J45	TX1 from Left GXB1 Block	GXB1_TX1 [p/n]	—	AB36, AB37	—
J42, J44	RX1 from Left GXB1 Block	GXB1_RX1 [p/n]	—	AC38, AC39	—
J55, J57	TX2 from Left GXB1 Block	GXB1_TX2 [p/n]	—	T36, T37	—
J54, J56	RX2 from Left GXB1 Block	GXB1_RX2 [p/n]	—	U38, U39	—
J59, J61	TX3 from Left GXB1 Block	GXB1_TX3 [p/n]	—	P36, P37	—
J58, J60	RX3 from Left GXB1 Block	GXB1_RX3 [p/n]	—	R38, R39	—
J34, J36	TX0 from Left GXB2 Block	GXB2_TX0 [p/n]	—	M36, M37	—
J30, J32	RX0 from Left GXB2 Block	GXB2_RX0 [p/n]	—	N38, N39	—
J31, J33	15 inches long transmitter TX1 channel from Left GXB2 Block	GXB2_TX1 [p/n]	—	K36, K37	—
J35, J37	5 inches long receiver RX1 channel from Left GXB2 Block	GXB2_RX1 [p/n]	—	L38, L39	—

All receive channels include a 0402 type 0.1- $\mu$ F DC blocking capacitor in series with the P and N signals to remove the DC component of the transmitted signal. The receivers internally regenerate the required DC offset. Blocking capacitors are not provided for transmit channels.

## Power

The board’s power is provided through a laptop style DC power input. The input voltage must be in the range of 14 V to 20 V. The DC voltage is then stepped down to the various power rails used by the components on the board. The slide switch (SW1) is the board power switch.

Table 2-29 lists the connection of this power switch.

**Table 2-29. Slide Switch Pin-Out (SW1)**

Board Reference	Description	Schematic Signal Name	I/O Standard	Stratix IV GT Device Pin Name	Other Connections
SW1	Power switch. Slide switch to ON position to power on the board. Slide switch to OFF position to power off the board.	RUN_SW	—	—	DC Input U1 pin A10 U2 pin A10 U3 pin A10

## Power Distribution System

Figure 2-10 shows the power distribution system on the board.

**Figure 2-10. Power Distribution System**

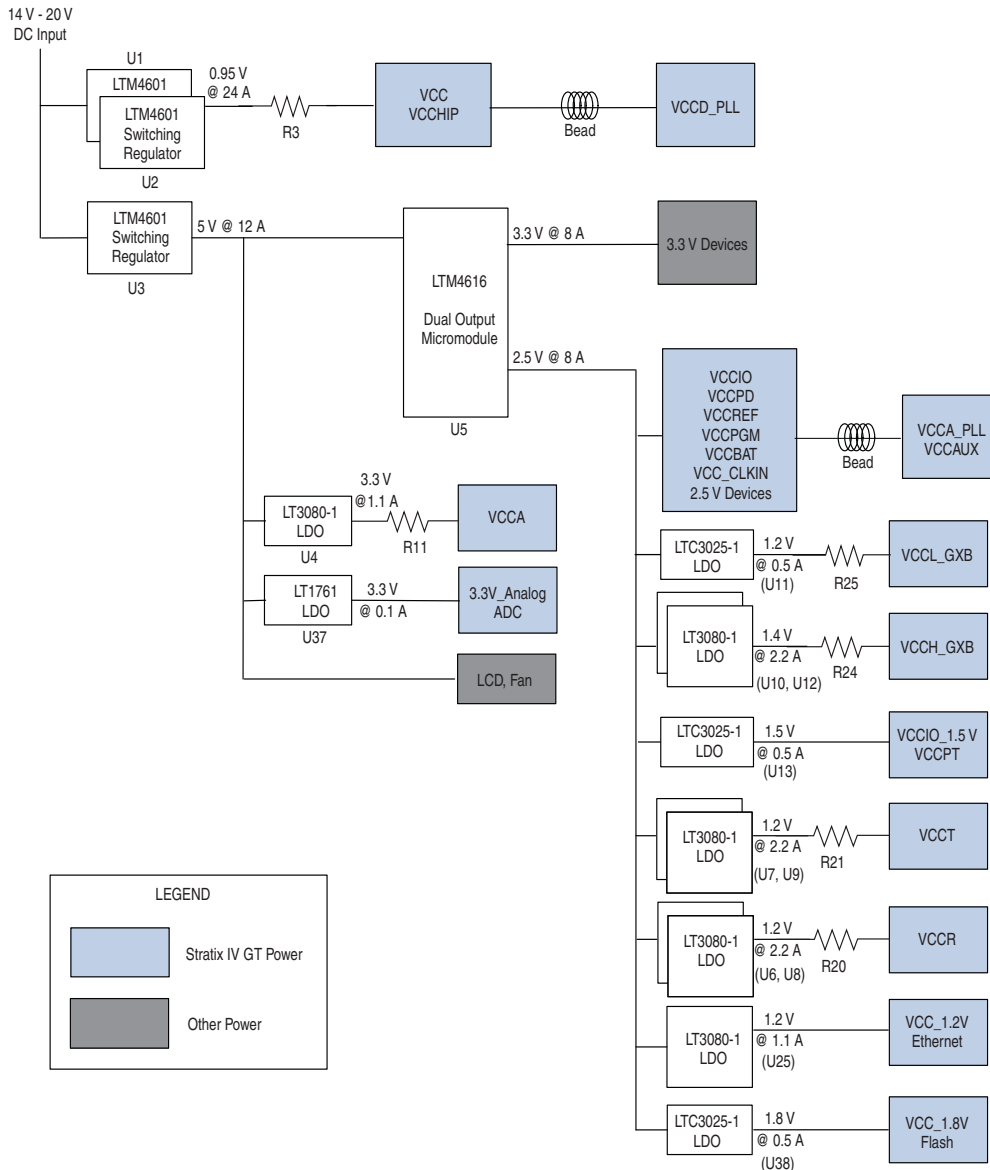

Table 2–30 lists the power components used on the board.

**Table 2–30. Voltage Regulator Component Reference**

Reference Designator	Device Description	Manufacturer	Manufacturer Part Number	Manufacturer Website
U1, U2, U3	12A $\mu$ Module Switching Regulator	Linear Technology	LTM4601EV#PBF	<a href="http://www.linear.com">www.linear.com</a>
U5	Dual 8A/Channel $\mu$ Module Switching Regulator	Linear Technology	LTM4616EV#PBF	<a href="http://www.linear.com">www.linear.com</a>
U4, U6, U7, U8, U9, U10, U12, U25	1.1A LDO Linear Regulator	Linear Technology	LT3080EDD-1#PBF	<a href="http://www.linear.com">www.linear.com</a>
U11, U13, U38	500 mA VLDO Linear Regulator	Linear Technology	LTC3025EDC-1#PBF	<a href="http://www.linear.com">www.linear.com</a>
U37	100 mA Low Noise LDO Linear Regulator	Linear Technology	LT1761ES5-SD#PBF	<a href="http://www.linear.com">www.linear.com</a>

## Banana Jacks and Fuses

In addition to the power supplied by the regulators, several power rails can be directly supplied by an external bench-top power supply through the on-board banana jacks (J2–J4, J7–J10). Figure 2–11 illustrates how the external power is allowed in through the banana jacks by first removing the fuses (F1–F7) associated with the power rail to be externally supplied.



Failure to remove the associated fuses (F1–F7) or improperly setting the external supply voltages too high can result in damage to the board.

**Figure 2–11. External Power Supplied through Banana Jack**

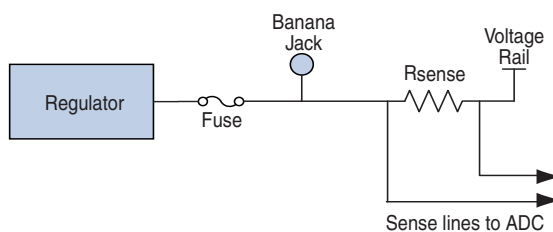

Table 2–31 summarizes the banana jacks and fuses associated with each power rail that can be supplied by external power.

**Table 2–31. Banana Jack and Fuses Component Reference (Part 1 of 2)**

Banana Jack Board Reference	Fuse Board Reference	Device Description	Manufacturer	Manufacturer Part Number	Manufacturer Website
J2	F1, F2	Banana jack and fuse for supplying external power to VCC core	Johnson Components	111-0702-001	<a href="http://www.johnsoncomponents.com">www.johnsoncomponents.com</a>
			Littelfuse Inc.	154 010.DR	<a href="http://www.littelfuse.com">www.littelfuse.com</a>

**Table 2-31. Banana Jack and Fuses Component Reference (Part 2 of 2)**

Banana Jack Board Reference	Fuse Board Reference	Device Description	Manufacturer	Manufacturer Part Number	Manufacturer Website
J3	F3	Banana jack and fuse for supplying external power to VCCA	Johnson Components	111-0702-001	<a href="http://www.johnsoncomponents.com">www.johnsoncomponents.com</a>
			Littelfuse Inc.	154 002	<a href="http://www.littelfuse.com">www.littelfuse.com</a>
J9	F6	Banana jack and fuse for supplying external power to VCCH	Johnson Components	111-0702-001	<a href="http://www.johnsoncomponents.com">www.johnsoncomponents.com</a>
			Littelfuse Inc.	154 005.DR	<a href="http://www.littelfuse.com">www.littelfuse.com</a>
J10	F7	Banana jack and fuse for supplying external power to VCCL	Johnson Components	111-0702-001	<a href="http://www.johnsoncomponents.com">www.johnsoncomponents.com</a>
			Littelfuse Inc.	154 002	<a href="http://www.littelfuse.com">www.littelfuse.com</a>
J7	F84	Banana jack and fuse for supplying external power to VCCR	Johnson Components	111-0702-001	<a href="http://www.johnsoncomponents.com">www.johnsoncomponents.com</a>
			Littelfuse Inc.	154 002	<a href="http://www.littelfuse.com">www.littelfuse.com</a>
J8	F5	Banana jack and fuse for supplying external power to VCCT	Johnson Components	111-0702-001	<a href="http://www.johnsoncomponents.com">www.johnsoncomponents.com</a>
			Littelfuse Inc.	154 002	<a href="http://www.littelfuse.com">www.littelfuse.com</a>
J4	—	Banana jack connected to board GND	Johnson Components	111-0703-001	<a href="http://www.johnsoncomponents.com">www.johnsoncomponents.com</a>
			Littelfuse Inc.	—	<a href="http://www.littelfuse.com">www.littelfuse.com</a>

This appendix catalogs revisions to the Stratix IV GT transceiver signal integrity development board.

Table A-1 lists the released versions of the Stratix IV GT transceiver signal integrity development board.

**Table A-1. Stratix IV GT Transceiver Signal Integrity Development Board Revision History**

Version	Release Date	Description
Single-die flash	November 2011	Replaced Intel dual-die 512-Mb flash PC48F4400POVB00 with Numonyx single-die 512-Mb flash PC28F512P30BF.
Production silicon	December 2009	Initial release.

## Single-Die Flash Version Differences

The single-die flash version of the Stratix IV GT transceiver signal integrity development board is created to replace the obsolete dual-die flash device with a single-die flash device. The two flash devices are considered equivalent except for some software routines used to access them because the single-die device has only one CFI table whereas the dual-die device has two CFI tables.

To determine which flash your board is using, refer to the device part number installed at U39. The single-die package is smaller than the dual-die version.

- For more information about the flash change and its application, refer to the *Transceiver Signal Integrity Kit, Stratix IV GT Edition User Guide*.



This chapter provides additional information about the document and Altera.

## Document Revision History

The following table lists the revision history for this document.

Date	Version	Changes
November 2011	1.1	<ul style="list-style-type: none"> <li>■ Added “<a href="#">Single-Die Flash Version Differences</a>” section to document the replacement of dual-die 512-Mb flash with a single-die 512-Mb flash device.</li> <li>■ Updated the flash device manufacturing part number in <a href="#">Table 2–16</a>.</li> <li>■ Converted the document to new frame template and made textual and style changes.</li> </ul>
December 2009	1.0	Initial release.

## How to Contact Altera

To locate the most up-to-date information about Altera products, refer to the following table.

Contact <sup>(1)</sup>	Contact Method	Address
Technical support	Website	<a href="http://www.altera.com/support">www.altera.com/support</a>
Technical training	Website	<a href="http://www.altera.com/training">www.altera.com/training</a>
	Email	<a href="mailto:custrain@altera.com">custrain@altera.com</a>
Product literature	Website	<a href="http://www.altera.com/literature">www.altera.com/literature</a>
Nontechnical support (general) (software licensing)	Email	<a href="mailto:nacomp@altera.com">nacomp@altera.com</a>
	Email	<a href="mailto:authorization@altera.com">authorization@altera.com</a>









**Note to Table:**

(1) You can also contact your local Altera sales office or sales representative.

## Typographic Conventions

The following table shows the typographic conventions this document uses.

Visual Cue	Meaning
<b>Bold Type with Initial Capital Letters</b>	Indicate command names, dialog box titles, dialog box options, and other GUI labels. For example, <b>Save As</b> dialog box. For GUI elements, capitalization matches the GUI.
<b>bold type</b>	Indicates directory names, project names, disk drive names, file names, file name extensions, software utility names, and GUI labels. For example, <code>\qdesigns</code> directory, <b>D:</b> drive, and <code>chiptrip.gdf</code> file.
<i>Italic Type with Initial Capital Letters</i>	Indicate document titles. For example, <i>Stratix IV Design Guidelines</i> .

Visual Cue	Meaning
<i>italic type</i>	Indicates variables. For example, $n + 1$ . Variable names are enclosed in angle brackets (< >). For example, <file name> and <project name>.pof file.
Initial Capital Letters	Indicate keyboard keys and menu names. For example, the Delete key and the Options menu.
“Subheading Title”	Quotation marks indicate references to sections in a document and titles of Quartus II Help topics. For example, “Typographic Conventions.”
Courier type	Indicates signal, port, register, bit, block, and primitive names. For example, data1, tdi, and input. The suffix n denotes an active-low signal. For example, resetn. Indicates command line commands and anything that must be typed exactly as it appears. For example, c:\qdesigns\tutorial\chiptrip.gdf. Also indicates sections of an actual file, such as a Report File, references to parts of files (for example, the AHDL keyword SUBDESIGN), and logic function names (for example, TRI).
	An angled arrow instructs you to press the Enter key.
1., 2., 3., and a., b., c., and so on	Numbered steps indicate a list of items when the sequence of the items is important, such as the steps listed in a procedure.
	Bullets indicate a list of items when the sequence of the items is not important.
	The hand points to information that requires special attention.
	The question mark directs you to a software help system with related information.
	The feet direct you to another document or website with related information.
	The multimedia icon directs you to a related multimedia presentation.
 CAUTION	A caution calls attention to a condition or possible situation that can damage or destroy the product or your work.
 WARNING	A warning calls attention to a condition or possible situation that can cause you injury.
	The envelope links to the <a href="#">Email Subscription Management Center</a> page of the Altera website, where you can sign up to receive update notifications for Altera documents.