



Stratix V GX FPGA Development Board

Reference Manual



101 Innovation Drive
San Jose, CA 95134
www.altera.com

MNL-01063-1.2



Subscribe

© 2012 Altera Corporation. All rights reserved. ALTERA, ARRIA, CYCLONE, HARDCOPY, MAX, MEGACORE, NIOS, QUARTUS and STRATIX are Reg. U.S. Pat. & Tm. Off. and/or trademarks of Altera Corporation in the U.S. and other countries. All other trademarks and service marks are the property of their respective holders as described at www.altera.com/common/legal.html. Altera warrants performance of its semiconductor products to current specifications in accordance with Altera's standard warranty, but reserves the right to make changes to any products and services at any time without notice. Altera assumes no responsibility or liability arising out of the application or use of any information, product, or service described herein except as expressly agreed to in writing by Altera. Altera customers are advised to obtain the latest version of device specifications before relying on any published information and before placing orders for products or services.



Chapter 1. Overview

General Description	1-1
Board Component Blocks	1-2
Development Board Block Diagram	1-4
Handling the Board	1-4

Chapter 2. Board Components

Introduction	2-1
Board Overview	2-2
Featured Device: Stratix V GX FPGA	2-5
I/O Resources	2-5
MAX V CPLD System Controller	2-6
Configuration, Status, and Setup Elements	2-12
Configuration	2-12
FPGA Programming over On-Board USB-Blaster II	2-12
FPGA Programming from Flash Memory	2-16
FPGA Programming over External USB-Blaster	2-17
Status Elements	2-18
Status LEDs	2-18
Setup Elements	2-19
Board Settings DIP Switch	2-19
JTAG Control DIP Switch	2-20
PCI Express Control DIP Switch	2-21
MAX V Reset Push Button	2-21
Program Load Push Button	2-21
Program Select Push Button	2-22
CPU Reset Push Button	2-22
Clock Circuitry	2-23
On-Board Oscillators	2-23
Off-Board Clock Input/Output	2-25
Memory Clocks	2-26
General User Input/Output	2-26
User-Defined Push Buttons	2-26
User-Defined DIP Switches	2-27
User-Defined LEDs	2-28
General User-Defined LEDs	2-28
HSMC User-Defined LEDs	2-29
Character LCD	2-29
Components and Interfaces	2-31
PCI Express	2-31
10/100/1000 Ethernet	2-34
High-Speed Mezzanine Cards (HSMC)	2-35
SDI Video Output/Input	2-43
40G QSFP Connector	2-45
Memory	2-46
DDR3	2-46
QDRII+	2-50
Flash	2-53

Power Supply	2-55
Power Distribution System	2-55
Power Measurement	2-57
Temperature Sense	2-58
Statement of China-RoHS Compliance	2-59

Appendix A. Board Revision History

Additional Information

Document Revision History	Info-1
How to Contact Altera	Info-2
Typographic Conventions	Info-2

This document describes the hardware features of the Stratix® V GX FPGA development board, including the detailed pin-out and component reference information required to create custom FPGA designs that interface with all components of the board.

General Description

The Stratix V GX FPGA development board provides a hardware platform for developing and prototyping high-performance and high-bandwidth application designs. The board provides a wide range of peripherals and memory interfaces to facilitate the development of Stratix V GX FPGA designs.

Two High-Speed Mezzanine Card (HSMC) connectors are available to add additional functionality via a variety of HSMC cards available from both Altera and various partners.

- To see a list of the latest HSMC cards available or to download a copy of the HSMC specification, refer to the [Development Board Daughtercards](#) page of the Altera website.

Design advancements and innovations, such as the PCI Express hard IP implementation, partial reconfiguration, and programmable power technology ensure that designs implemented in the Stratix V GX FPGAs operate faster, with lower power than in previous FPGA families.

- For more information on the following topics, refer to the respective documents:
 - Stratix V device family, refer to the [Stratix V Device Handbook](#).
 - PCI Express hard IP implementation, refer to the [Stratix V Hard IP for PCI Express User Guide](#).
 - HSMC Specification, refer to the [High Speed Mezzanine Card \(HSMC\) Specification](#).

Board Component Blocks

The board features the following major component blocks:

- Altera Stratix V FPGA (5SGXEA7K2F40C2) in the 1517-pin FineLine BGA Package
 - 622,000 LEs
 - 358,500 adaptive logic modules (ALMs)
 - 50-Mbits embedded memory
 - 36 transceivers (12.5 Gbps)
 - 174 full-duplex LVDS channels
 - 28 phase locked loops (PLLs)
 - 512 18x18-bit multipliers
 - 850-mV core voltage
 - 696 user I/Os
 - 2 PCI Express hard IP blocks
- MAX[®] V CPLD (5M2210ZF256C4) System Controller in the 256-pin FineLine BGA Package
 - 2,210 LEs
 - 203 user I/Os
 - 1.8-V core voltage
- FPGA Configuration Circuitry
 - MAX II CPLD (EPM570GM100) and Flash Fast Passive Parallel (FPP) configuration
 - On-Board USB-Blaster[™] II for use with the Quartus[®] II Programmer, Nios[®] II Software Build Tools, and System Console.
- On-Board Clocking Circuitry
 - 50-MHz, 100-MHz, 125-MHz, and programmable oscillators
 - SMA connector for clock input (LVPECL)
- Memory devices
 - 1152-Mbyte DDR3 SDRAM with a 72-bit data bus
 - 4.5-Mbyte QDR II+ SRAM with a 18-bit data bus (footprint is compatible for 9-Mbyte QDR II with a 18-bit data bus)
 - Two 512-Mbyte synchronous flash with a 16-bit data bus

- Communication Ports
 - PCI Express (PCIe) x8 edge connector
 - Two HSMC ports
 - One universal HSMC port A
 - One DQS-type HSMC port B
 - SMB for SDI input and output
 - QSFP
 - USB 2.0
 - Gigabit Ethernet
 - LCD header
- General User I/O
 - 16 user LEDs
 - Two-line character LCD display
 - Six configuration status LEDs
 - Five PCI Express LEDs
 - Four Ethernet LEDs
- Push Button and DIP Switches
 - One CPU reset push button
 - Three general user push buttons
 - Two configuration push buttons
 - Eight user DIP switches
 - Four MAX V control DIP switches
- Power
 - 19-V (laptop) DC input
 - PCI Express edge connector power
 - On-Board power measurement circuitry
- System Monitoring
 - Power—voltage, current, wattage
 - Temperature—FPGA die, local board
- Mechanical
 - PCI Express short form factor
 - PCI Express chassis or bench-top operation

Development Board Block Diagram

Figure 1-1 shows the block diagram of the Stratix V GX FPGA Development Board.

Figure 1-1. Stratix V GX FPGA Development Board Block Diagram

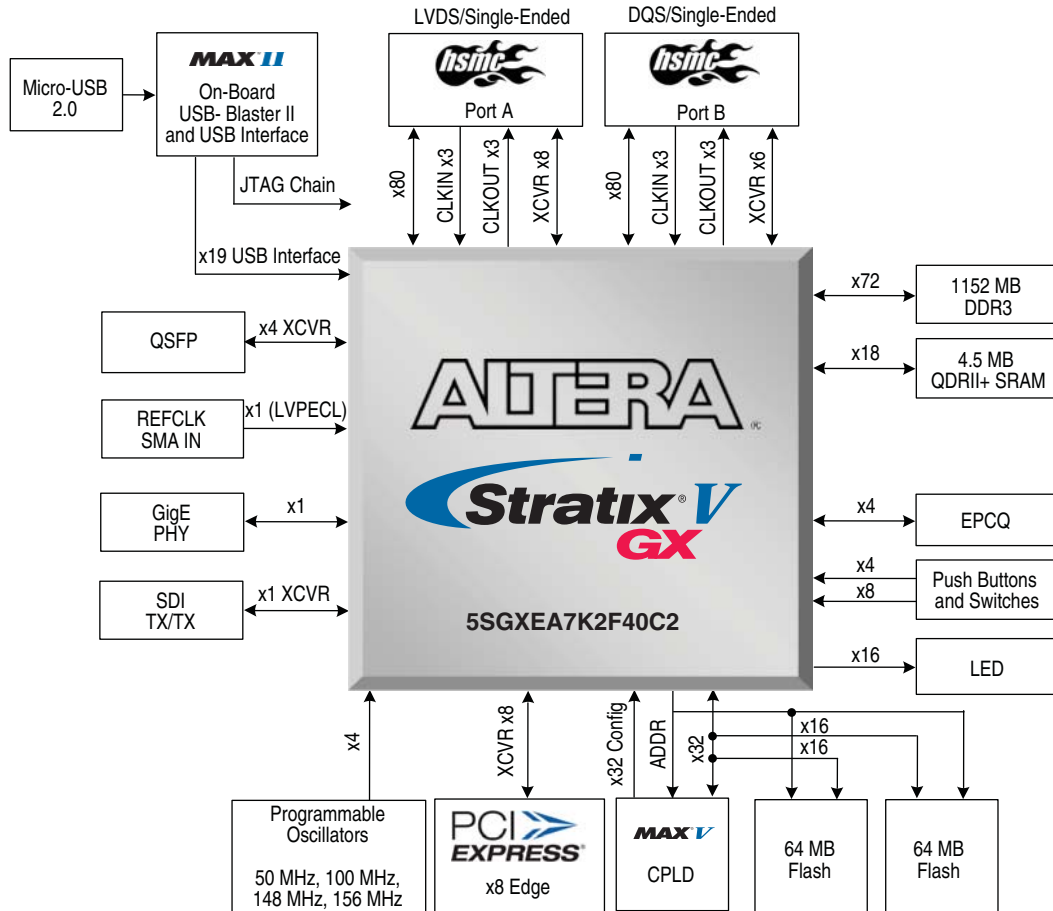

Handling the Board

When handling the board, it is important to observe the following static discharge precaution:



Without proper anti-static handling, the board can be damaged. Therefore, use anti-static handling precautions when touching the board.

Introduction

This chapter introduces all the important components on the Stratix V GX FPGA Development Board. [Figure 2–1](#) illustrates major component locations and [Table 2–1](#) provides a brief description of all features of the board.



A complete set of schematics, a physical layout database, and GERBER files for the development board reside in the Stratix V GX FPGA development kit documents directory.



For information about powering up the board and installing the demo software, refer to the [Stratix V GX FPGA Development Kit User Guide](#).

This chapter consists of the following sections:

- “Board Overview”
- “Featured Device: Stratix V GX FPGA” on page 2–5
- “MAX V CPLD System Controller” on page 2–6
- “Configuration, Status, and Setup Elements” on page 2–12
- “Clock Circuitry” on page 2–23
- “General User Input/Output” on page 2–26
- “Components and Interfaces” on page 2–31
- “Memory” on page 2–46
- “Power Supply” on page 2–55
- “Statement of China-RoHS Compliance” on page 2–59

Board Overview

This section provides an overview of the Stratix V GX FPGA development board, including an annotated board image and component descriptions. Figure 2-1 provides an overview of the development board features.

Figure 2-1. Overview of the Stratix V GX FPGA Development Board Features

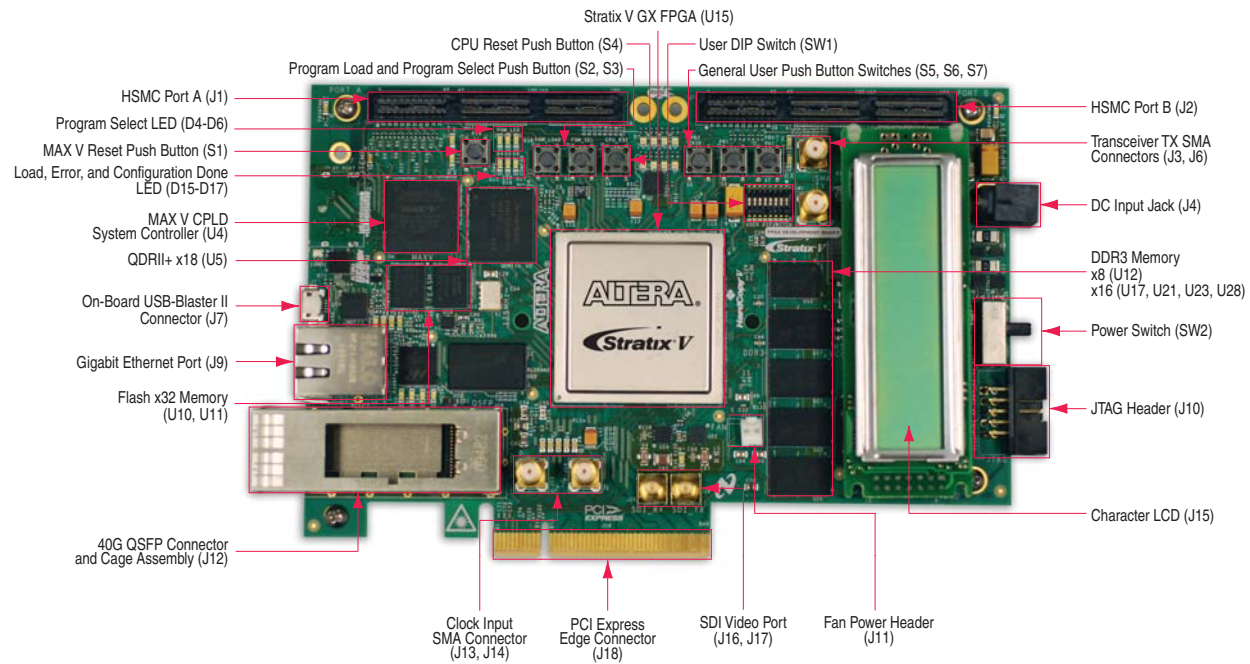

Table 2-1 describes the components and lists their corresponding board references.

Table 2-1. Stratix V GX FPGA Development Board Components (Part 1 of 4)

Board Reference	Type	Description
Featured Devices		
U15	FPGA	5SGXEA7K2F40C2, 1517-pin BGA.
U4	CPLD	5M2210ZF256C4, 256-pin BGA.
Configuration, Status, and Setup Elements		
J10	JTAG header	Provides access to the JTAG chain by using an external USB-Blaster cable (disables the on-board USB-Blaster II).
J7	On-Board USB-Blaster II	Micro-USB 2.0 connector for programming and debugging the FPGA.
SW3	JTAG DIP switch	Enables and disables devices in the JTAG chain. This switch is located on the back of the board.
SW4	FPGA mode select DIP switch	Sets the Stratix V MSEL [4 : 0] pins.
SW5	Board settings DIP switch	Controls the MAX V CPLD System Controller functions such as clock select, clock enable, factory or user design load from flash and FACTORY signal command sent at power up. This switch is located at the bottom of the board.

Table 2–1. Stratix V GX FPGA Development Board Components (Part 2 of 4)

Board Reference	Type	Description
SW6	PCI Express DIP switch	Controls the PCI Express lane width by connecting <code>prsn</code> pins together on the PCI Express edge connector. This switch is located at the back of the board.
S3	Program select push button	Toggles the program LEDs which selects the program image that loads from flash memory to the FPGA.
S2	Program load push button	Configures the FPGA from flash memory image based on the program LEDs.
D4, D5, D6	Program LEDs	Illuminates to show the LED sequence that determines which flash memory image loads to the FPGA when you press the program load push button.
D17	Configuration done LED	Illuminates when the FPGA is configured.
D15	Load LED	Illuminates during FPGA configuration.
D16	Error LED	Illuminates when the FPGA configuration from flash fails.
D24	Power LED	Illuminates when 5-V power is present.
D25, D26	System Console TX/RX LEDs	Indicate the transmit or receive activity of the System Console USB interface. The TX and RX LEDs would flicker if the link is in use and active. The LEDs are either off when not in use or on when in use but idle.
D27, D28	JTAG TX/RX LEDs	Indicate the transmit or receive activity of the JTAG chain. The TX and RX LEDs would flicker if the link is in use and active. The LEDs are either off when not in use or on when in use but idle.
D29, D30, D31, D32	Ethernet LEDs	Indicate the connection speed as well as transmit or receive activity.
D3, D13	HSMC port A LEDs	You can configure these LEDs to indicate transmit or receive activity.
D1	HSMC port A Present LED	Illuminates when a daughtercard is plugged into the HSMC port A.
D11, D14	HSMC port B LEDs	You can configure these LEDs to indicate transmit or receive activity.
D2	HSMC port B Present LED	Illuminates when a daughtercard is plugged into the HSMC port B.
D33, D34	PCI Express Gen2/Gen3 LED	You can configure these LEDs to illuminate when PCI Express is in Gen2 or Gen3 mode.
D35, D36, D37	PCI Express Link LEDs	You can configure these LEDs to display the PCI Express link width (x1, x4, x8).
Clock Circuitry		
X1	125 M oscillator	125.000-MHz crystal oscillator for Gigabit Ethernet, Serial RapidIO™ (SRIO), or PCI Express.
U38	Quad-output oscillator	Programmable oscillator with default frequencies of 100 MHz, 156.25 MHz, 625 MHz, and 270 MHz.
U46	Quad-output oscillator	Programmable oscillator with default frequencies of 125 MHz, 644.53125 MHz, 282.5 MHz, and 125 MHz.
X6	148.5 M oscillator	148.500-MHz voltage controlled crystal oscillator for SDI video. This oscillator is programmable to any frequency between 20–810 MHz.
X4	100 M oscillator	100.000-MHz (programmable to any frequency between 20–810 MHz) crystal oscillator for PCI Express or general use such as memories. Multiplex with <code>CLKIN_SMA_P</code> or <code>CLKIN_SMA_N</code> based on <code>CLK_SEL</code> switch value.

Table 2-1. Stratix V GX FPGA Development Board Components (Part 3 of 4)

Board Reference	Type	Description
X3	50 M oscillator	50.000-MHz crystal oscillator for general purpose logic.
J13, J14	Clock input SMAs	Drives LVPECL-compatible clock inputs into the clock multiplexer buffer.
U4	100 M oscillator	100-MHz crystal oscillator for the MAX V CPLD System Controller.
General User Input and Output		
D7-D10, D18-D21	User LEDs	Eight bi-color LEDs (green and red) for 16 user LEDs. Illuminates when driven low.
SW1	User DIP switch	Octal user DIP switches. When the switch is ON, a logic 0 is selected.
S1	MAX V reset push button	The default reset for the MAX V CPLD System Controller.
S4	CPU reset push button	The default reset for the FPGA logic.
S5, S6, S7	General user push button	Three user push buttons. Driven low when pressed.
Memory Devices		
U12, U17, U21, U23, U28	DDR3 x72	A 1152-Mbyte DDR3 SDRAM with a 72-bit data bus. The 72-bit data bus consists of four x16 devices and one x8 device with a single address or command bus.
U5	QDRII+ x18	A 4.5-Mbyte QDRII+ SRAM with a 18-bit data bus. The device has a separate 18-bit read and 18-bit write port with DDR signalling at up to 550 MHz.
U10, U11	Flash x32	Two 512-Mbyte synchronous flash devices with a 16-bit data buses for non-volatile memory. The board supports two flash devices of 16-bit interface each, which combine to allow for 1-Gbyte synchronous flash with a 32-bit data bus.
Communication Ports		
J18	PCI Express edge connector	Made of gold-plated edge fingers for up to x8 signaling in either Gen1, Gen2, or Gen3 mode.
J12	QSFP connector	Provides four transceiver channels for a 40G QSFP module.
J1	HSMC port A	Provides eight transceiver channels and 84 CMOS or 17 LVDS channels per the HSMC specification.
J2	HSMC port B	Provides four transceiver channels and 84 CMOS or a DQ/DQS interface.
J9	Gigabit Ethernet port	RJ-45 connector which provides a 10/100/1000 Ethernet connection via a Marvell 88E1111 PHY and the FPGA-based Altera Triple Speed Ethernet MAC MegaCore function in SGMII mode.
Video and Display Ports		
J16, J17	SDI video port	Two 75-Ω system management bus (SMB) connectors which provide a full-duplex SDI interface through a LMH0303 driver and LMH0384 cable equalizer.
J15	Character LCD header	A single 14-pin 0.1" pitch dual-row header which interfaces to the 16 character x 2 line LCD module.
Power Supply		
J18	PCI Express edge connector	Interfaces to a PCI Express root port such as an appropriate PC motherboard.

Table 2-1. Stratix V GX FPGA Development Board Components (Part 4 of 4)

Board Reference	Type	Description
J4	DC input jack	Accepts a 19-V DC power supply.
SW2	Power switch	Switch to power on or off the board when power is supplied from the DC input jack.

Featured Device: Stratix V GX FPGA

The Stratix V GX FPGA development board features the Stratix V GX FPGA 5SGXEA7K2F40C2 device (U15) in a 1517-pin FineLine BGA package.



For more information about the Stratix V device family, refer to the *Stratix V Device Handbook*.

Table 2-2 describes the features of the Stratix V GX FPGA 5SGXEA7K2F40C2 device.

Table 2-2. Stratix V GX FPGA 5SGXEA7K2F40C2 Features

ALMs	Equivalent LEs	Registers	M20K Blocks	MLAB Blocks (Mb)	18-bit × 18-bit Multipliers	PLLs	Transceiver Channels (12.5 Gbps)	Package Type
358,500	622,000	939,000	2,560	7.16	512	28	36	1517-pin FineLine BGA

Table 2-3 lists the Stratix V GX FPGA component reference and manufacturing information.

Table 2-3. Stratix V GX FPGA Component Reference and Manufacturing Information

Board Reference	Description	Manufacturer	Manufacturing Part Number	Manufacturer Website
U15	FPGA, Stratix V GX F1517, 622K LEs, leadfree	Altera Corporation	5SGXEA7K2F40C2C2N	www.altera.com

I/O Resources

Table 2-4 lists the Stratix V GX FPGA device pin count and usage by function on the development board.

Table 2-4. Stratix V GX FPGA Pin Count and Usage (Part 1 of 2)

Function	I/O Standard	I/O Count	Special Pins
DDR3	1.5-V SSTL	126	1 Diff ×9DQS
QDRII+ SRAM	1.8-V HSTL	67	1 Diff ×2 DQS
MAX V System Controller	1.5-V CMOS	8	—
Flash	1.8-V CMOS	68	—
PCI Express ×8	2.5-V CMOS + XCVR	43	1 REFCLK
HSMC Port A	2.5-V CMOS + LVDS + XCVR	118	1 REFCLK
HSMC Port B	2.5-V CMOS + DQS + XCVR	104	1 REFCLK
Gigabit Ethernet	2.5-V CMOS + LVDS	8	—

Table 2-4. Stratix V GX FPGA Pin Count and Usage (Part 2 of 2)

Function	I/O Standard	I/O Count	Special Pins
On-Board USB-Blaster II	1.5-V CMOS	18	—
	3.3-V CMOS	1	—
SDI Video	2.5-V CMOS + XCVR	8	1 REFCLK
QSFP	2.5-V CMOS + XCVR	23	1 REFCLK
Buttons	1.8/2.5-V CMOS	4	1 DEV_CLRn
Switches	1.8-V CMOS	8	—
Character LCD	2.5-V CMOS	11	—
LEDs	1.8/2.5-V CMOS	16	—
Clocks or Oscillators	1.8-V CMOS + LVDS	25	9 REFCLK
Device I/O Total:		713	

MAX V CPLD System Controller

The board utilizes the 5M2210ZF256C4 System Controller, an Altera MAX V CPLD, for the following purposes:

- FPGA configuration from flash memory
- Power consumption monitoring
- Temperature monitoring
- Fan control
- Control registers for clocks
- Control registers for remote system update

Figure 2-2 illustrates the MAX V CPLD System Controller's functionality and external circuit connections as a block diagram.

Figure 2-2. MAX V CPLD System Controller Block Diagram

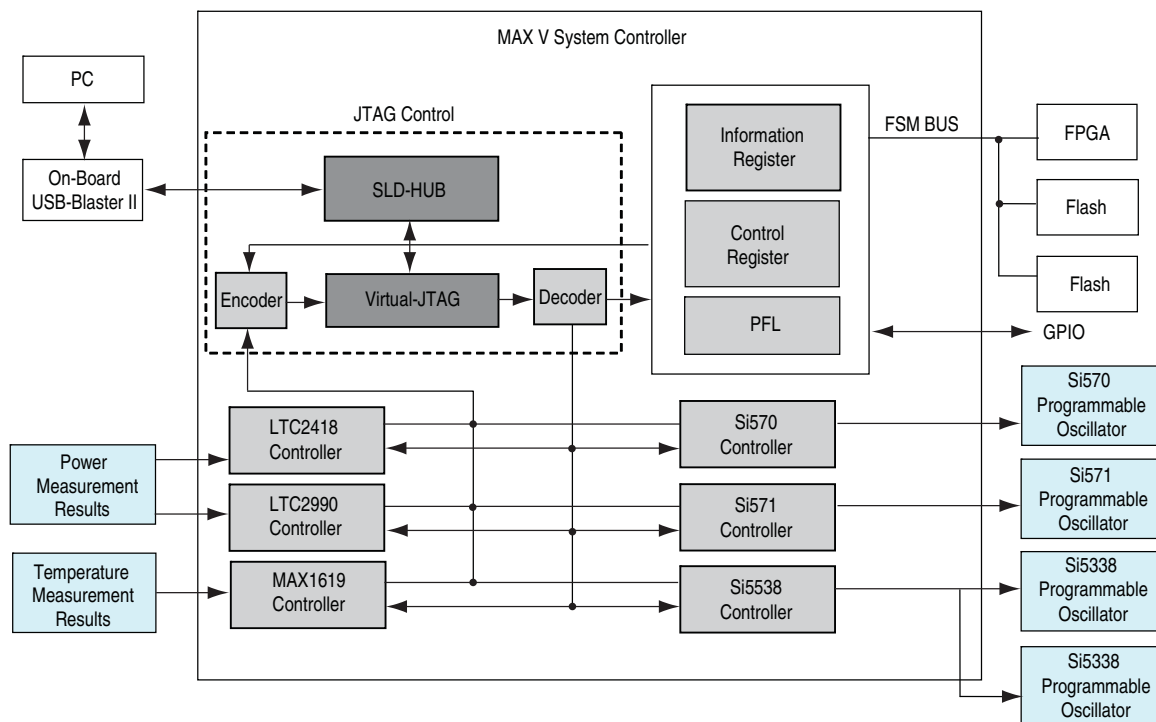

Table 2-5 lists the I/O signals present on the MAX V CPLD System Controller. The signal names and functions are relative to the MAX V device (U4).

Table 2-5. MAX V CPLD System Controller Device Pin-Out (Part 1 of 6)

Schematic Signal Name	MAX V CPLD Pin Number	Stratix V GX FPGA Pin Number	I/O Standard	Description
5M2210_JTAG_TMS	N4	—	2.5-V	MAX V JTAG TMS
CLK125_EN	B9	—	2.5-V	125 MHz oscillator enable
CLK50_EN	E9	—	2.5-V	50 MHz oscillator enable
CLK_CONFIG	J5	—	2.5-V	100 MHz configuration clock input
CLK_ENABLE	A15	—	2.5-V	DIP - clock oscillator enable
CLK_SEL	A13	—	2.5-V	DIP - clock select SMA or oscillator
CLKIN_50	J12	AN6	1.8-V	50 MHz clock input
CLOCK_SCL	C9	—	2.5-V	Programmable oscillator I ² C clock
CLOCK_SDA	D9	—	2.5-V	Programmable oscillator I ² C data
CPU_RESETn	D10	AM34	2.5-V	FPGA reset push button
FACTORY_LOAD	A2	—	2.5-V	DIP - load factory image or user1 image from flash at power-up
FACTORY_REQUEST	R14	—	1.8-V	On-Board USB-Blaster II request to send FACTORY command

Table 2-5. MAX V CPLD System Controller Device Pin-Out (Part 2 of 6)

Schematic Signal Name	MAX V CPLD Pin Number	Stratix V GX FPGA Pin Number	I/O Standard	Description
FACTORY_STATUS	N12	—	1.8-V	On-Board USB-Blaster II FACTORY command status
FLASH_ADVn	N7	AP7	1.8-V	FM bus flash memory address valid
FLASH_CEn0	R5	AV14	1.8-V	FM bus flash memory chip enable 0
FLASH_CEn1	M7	AW13	1.8-V	FM bus flash memory chip enable 1
FLASH_CLK	R6	AM8	1.8-V	FM bus flash memory clock
FLASH_OEn	M6	AJ7	1.8-V	FM bus flash memory output enable
FLASH_RDYBSYN0	T5	AL6	1.8-V	FM bus flash memory chip ready 0
FLASH_RDYBSYN1	R7	AN7	1.8-V	FM bus flash memory chip ready 1
FLASH_RESETh	P7	AJ6	1.8-V	FM bus flash memory reset
FLASH_WEn	N6	AN8	1.8-V	FM bus flash memory write enable
FM_A0	E14	AW19	1.8-V	FM address bus
FM_A1	C14	AV19	1.8-V	FM address bus
FM_A2	C15	AM16	1.8-V	FM address bus
FM_A3	E13	AL16	1.8-V	FM address bus
FM_A4	E12	AF16	1.8-V	FM address bus
FM_A5	D15	AG16	1.8-V	FM address bus
FM_A6	F14	AN17	1.8-V	FM address bus
FM_A7	D16	AM17	1.8-V	FM address bus
FM_A8	F13	AP16	1.8-V	FM address bus
FM_A9	E15	AN16	1.8-V	FM address bus
FM_A10	E16	AT17	1.8-V	FM address bus
FM_A11	F15	AR17	1.8-V	FM address bus
FM_A12	G14	AU16	1.8-V	FM address bus
FM_A13	F16	AU17	1.8-V	FM address bus
FM_A14	G13	AW16	1.8-V	FM address bus
FM_A15	G15	AV16	1.8-V	FM address bus
FM_A16	G12	AW17	1.8-V	FM address bus
FM_A17	G16	AV17	1.8-V	FM address bus
FM_A18	H14	AU6	1.8-V	FM address bus
FM_A19	H15	AT6	1.8-V	FM address bus
FM_A20	H13	AL17	1.8-V	FM address bus
FM_A21	H16	AK17	1.8-V	FM address bus
FM_A22	J13	AE16	1.8-V	FM address bus
FM_A23	R3	AE17	1.8-V	FM address bus
FM_A24	P5	AH16	1.8-V	FM address bus
FM_A25	T2	AP21	1.8-V	FM address bus
FM_D0	J14	AN21	1.8-V	FM data bus
FM_D1	J15	AD21	1.8-V	FM data bus

Table 2-5. MAX V CPLD System Controller Device Pin-Out (Part 3 of 6)

Schematic Signal Name	MAX V CPLD Pin Number	Stratix V GX FPGA Pin Number	I/O Standard	Description
FM_D2	K16	AD20	1.8-V	FM data bus
FM_D3	K13	AG21	1.8-V	FM data bus
FM_D4	K15	AH21	1.8-V	FM data bus
FM_D5	K14	AE21	1.8-V	FM data bus
FM_D6	L16	AE20	1.8-V	FM data bus
FM_D7	L11	AL22	1.8-V	FM data bus
FM_D8	L15	AK21	1.8-V	FM data bus
FM_D9	L12	AJ21	1.8-V	FM data bus
FM_D10	M16	AJ20	1.8-V	FM data bus
FM_D11	L13	AL21	1.8-V	FM data bus
FM_D12	M15	AL20	1.8-V	FM data bus
FM_D13	L14	AN25	1.8-V	FM data bus
FM_D14	N16	AM25	1.8-V	FM data bus
FM_D15	M13	AP24	1.8-V	FM data bus
FM_D16	N15	AN24	1.8-V	FM data bus
FM_D17	N14	AC24	1.8-V	FM data bus
FM_D18	P15	AB24	1.8-V	FM data bus
FM_D19	P14	AF25	1.8-V	FM data bus
FM_D20	D13	AE25	1.8-V	FM data bus
FM_D21	D14	AE24	1.8-V	FM data bus
FM_D22	F11	AD24	1.8-V	FM data bus
FM_D23	J16	AG24	1.8-V	FM data bus
FM_D24	F12	AH24	1.8-V	FM data bus
FM_D25	K12	AK24	1.8-V	FM data bus
FM_D26	M14	AJ24	1.8-V	FM data bus
FM_D27	N13	AL24	1.8-V	FM data bus
FM_D28	R1	AL25	1.8-V	FM data bus
FM_D29	P4	AW25	1.8-V	FM data bus
FM_D30	N5	AV25	1.8-V	FM data bus
FM_D31	P6	AT24	1.8-V	FM data bus
FPGA_CONF_DONE	K1	AH6	2.5-V	FPGA configuration done
FPGA_CONFIG_D0	D3	AP33	2.5-V	FPGA configuration data
FPGA_CONFIG_D1	C2	AT33	2.5-V	FPGA configuration data
FPGA_CONFIG_D2	C3	AR33	2.5-V	FPGA configuration data
FPGA_CONFIG_D3	E3	AU34	2.5-V	FPGA configuration data
FPGA_CONFIG_D4	D2	AU33	2.5-V	FPGA configuration data
FPGA_CONFIG_D5	E4	AN31	2.5-V	FPGA configuration data
FPGA_CONFIG_D6	D1	AM31	2.5-V	FPGA configuration data
FPGA_CONFIG_D7	E5	AU32	2.5-V	FPGA configuration data

Table 2-5. MAX V CPLD System Controller Device Pin-Out (Part 4 of 6)

Schematic Signal Name	MAX V CPLD Pin Number	Stratix V GX FPGA Pin Number	I/O Standard	Description
FPGA_CONFIG_D8	F3	AT32	2.5-V	FPGA configuration data
FPGA_CONFIG_D9	E1	AR31	2.5-V	FPGA configuration data
FPGA_CONFIG_D10	F4	AP31	2.5-V	FPGA configuration data
FPGA_CONFIG_D11	F2	AW34	2.5-V	FPGA configuration data
FPGA_CONFIG_D12	F1	AV34	2.5-V	FPGA configuration data
FPGA_CONFIG_D13	F6	AW31	2.5-V	FPGA configuration data
FPGA_CONFIG_D14	G2	AV31	2.5-V	FPGA configuration data
FPGA_CONFIG_D15	G3	AW32	2.5-V	FPGA configuration data
FPGA_CONFIG_D16	G1	AV32	2.5-V	FPGA configuration data
FPGA_CONFIG_D17	G4	AJ33	2.5-V	FPGA configuration data
FPGA_CONFIG_D18	H2	AH33	2.5-V	FPGA configuration data
FPGA_CONFIG_D19	G5	AL33	2.5-V	FPGA configuration data
FPGA_CONFIG_D20	H3	AK33	2.5-V	FPGA configuration data
FPGA_CONFIG_D21	J1	AK32	2.5-V	FPGA configuration data
FPGA_CONFIG_D22	J2	AJ32	2.5-V	FPGA configuration data
FPGA_CONFIG_D23	H5	AH31	2.5-V	FPGA configuration data
FPGA_CONFIG_D24	K2	AG31	2.5-V	FPGA configuration data
FPGA_CONFIG_D25	K5	AF31	2.5-V	FPGA configuration data
FPGA_CONFIG_D26	L1	AE31	2.5-V	FPGA configuration data
FPGA_CONFIG_D27	L2	AJ30	2.5-V	FPGA configuration data
FPGA_CONFIG_D28	K3	AH30	2.5-V	FPGA configuration data
FPGA_CONFIG_D29	M2	AR30	2.5-V	FPGA configuration data
FPGA_CONFIG_D30	L4	AP30	2.5-V	FPGA configuration data
FPGA_CONFIG_D31	L3	AU30	2.5-V	FPGA configuration data
FPGA_CVP_CONFDONE	N3	AT29	2.5-V	FPGA configuration via protocol done
FPGA_DCLK	J3	AC31	2.5-V	FPGA configuration clock
FPGA_nCONFIG	N1	AK35	2.5-V	FPGA configuration active
FPGA_nSTATUS	J4	AM5	2.5-V	FPGA configuration ready status
FPGA_PR_DONE	H1	AT30	2.5-V	FPGA partial reconfiguration done
FPGA_PR_ERROR	P2	AU29	2.5-V	FPGA partial reconfiguration error
FPGA_PR_READY	E2	AN29	2.5-V	FPGA partial reconfiguration ready
FPGA_PR_REQUEST	F5	AN30	2.5-V	FPGA partial reconfiguration request
HSMA_PRSENTn	B8	AW8	2.5-V	HSMC port A present
HSMB_PRSENTn	A8	AU7	2.5-V	HSMC port B present
M570_CLOCK	P11	—	1.8-V	25-MHz clock to on-board USB-Blaster for sending FACTORY command
M570_PCIE_JTAG_EN	P12	—	1.8-V	A low signal disables the on-board USB-Blaster when PCIe masters the JTAG
MAX5_BEN0	P10	U31	1.8-V	MAX V byte enable 0

Table 2-5. MAX V CPLD System Controller Device Pin-Out (Part 5 of 6)

Schematic Signal Name	MAX V CPLD Pin Number	Stratix V GX FPGA Pin Number	I/O Standard	Description
MAX5_BEN1	R11	T31	1.8-V	MAX V byte enable 1
MAX5_BEN2	T12	N33	1.8-V	MAX V byte enable 2
MAX5_BEN3	N11	M33	1.8-V	MAX V byte enable 3
MAX5_CLK	T11	E34	1.8-V	MAX V clock
MAX5_CSN	R10	B32	1.8-V	MAX V chip select
MAX5_OEN	M10	A32	1.8-V	MAX V output enable
MAX5_WEN	N10	A34	1.8-V	MAX V write enable
MAX_CONF_DONE	E11	—	1.8-V	FPGA configuration done LED
MAX_ERROR	A4	—	1.8-V	FPGA configuration error LED
MAX_LOAD	A6	—	1.8-V	FPGA configuration active LED
MAX_RESETn	M9	—	1.8-V	MAX V reset push button
MSEL0	B10	AA9	2.5-V	DIP - FPGA mode select 0
MSEL1	B3	AA10	2.5-V	DIP - FPGA mode select 1
MSEL2	C10	AD8	2.5-V	DIP - FPGA mode select 2
MSEL3	C12	AG8	2.5-V	DIP - FPGA mode select 3
MSEL4	C6	AH7	2.5-V	DIP - FPGA mode select 4
OVERTEMP	B7	—	2.5-V	Temperature monitor fan enable
OVERTEMPn	C8	—	2.5-V	Temperature monitor over-temperature indicator LED
PCIE_JTAG_EN	C7	—	2.5-V	DIP switch to enable the PCIe JTAG master
PGM_CONFIG	D12	—	2.5-V	Loads the flash memory image identified by the PGM LEDs
PGM_LED0	B14	—	2.5-V	Flash memory PGM select indicator 0
PGM_LED1	C13	—	2.5-V	Flash memory PGM select indicator 1
PGM_LED2	B16	—	2.5-V	Flash memory PGM select indicator 2
PGM_SEL	B13	—	2.5-V	Toggles the PGM_LED[0:2] sequence
SDI_RX_BYPASS	D5	AB30	2.5-V	SDI equalization bypass
SDI_RX_EN	E8	AB28	2.5-V	SDI receive enable
SDI_TX_EN	D11	AK27	2.5-V	SDI transmit enable
SECURITY_MODE	R12	—	1.8-V	DIP - On-board USB-Blaster II send FACTORY command at power up.
SENSE_CS0n	E7	—	2.5-V	Power monitor chip select
SENSE_SCK	A5	—	2.5-V	Power monitor SPI clock
SENSE_SDI	D7	—	2.5-V	Power monitor SPI data in
SENSE_SDO	B6	—	2.5-V	Power monitor SPI data out
SENSE_SMB_CLK	D8	—	2.5-V	Temperature monitor SMB clock
SENSE_SMB_DATA	A7	—	2.5-V	Temperature monitor SMB data
SI570_EN	A10	—	2.5-V	Si570 programmable oscillator enable

Table 2-5. MAX V CPLD System Controller Device Pin-Out (Part 6 of 6)

Schematic Signal Name	MAX V CPLD Pin Number	Stratix V GX FPGA Pin Number	I/O Standard	Description
SI571_EN	D4	—	2.5-V	Si571 programmable VCXO enable
TSENSE_ALERTn	B5	—	2.5-V	Temperature monitor alert

Table 2-6 lists the MAX V CPLD System Controller component reference and manufacturing information.

Table 2-6. MAX V CPLD EPM2210 System Controller Component Reference and Manufacturing Information

Board Reference	Description	Manufacturer	Manufacturing Part Number	Manufacturer Website
U4	MAX V CPLD 2210 LE 256FBGA LF 1.8V VCCINT	Altera Corporation	5M2210ZF256C4N	www.altera.com

Configuration, Status, and Setup Elements

This section describes the board's configuration, status, and setup elements.

Configuration

This section describes the FPGA, flash memory, and MAX V CPLD System Controller device programming methods that the Stratix V GX FPGA development board supports.

The Stratix V GX FPGA development board supports three configuration methods:

- On-Board USB-Blaster II is the default method for configuring the FPGA at any time using the Quartus II Programmer in JTAG mode with the supplied micro-USB cable.
- Flash memory download for configuring the FPGA using stored images from the flash memory on either power-up or pressing the program load push button (S2).
- External USB-Blaster for configuring the FPGA using the external USB-Blaster.

FPGA Programming over On-Board USB-Blaster II

The on-board USB-Blaster II is implemented using a micro-USB type-B connector (J7), a USB 2.0 PHY device, and an Altera MAX II CPLD EPM570GM100 (U14). This allows the configuration of the FPGA using a USB cable which connects directly between the USB port on the board (J7) and a USB port on a PC running the Quartus II software. The on-board USB-Blaster II normally masters the JTAG chain.



For more information about the on-board USB-Blaster II, refer to the [on-board USB-Blaster II](#) page of the Altera Wiki website.

MAX II CPLD EPM570GM100

The MAX II CPLD is dedicated to the on-board USB-Blaster II functionality. The CPLD connects to the CY7C68013A USB 2.0 PHY device on one side and drives the JTAG and System Console direct USB signals out the other side through the general purpose I/O (GPIO) pins.

Table 2-7 lists the I/O signals present on the MAX II CPLD EPM570GM100.

Table 2-7. MAX II CPLD EPM570GM100 On-Board USB-Blaster II I/O Signals

Schematic Signal Name	Type	Description
SC_RX	1.5-V CMOS output	USB system console receive LED
SC_TX	1.5-V CMOS output	USB system console transmit LED
JTAG_RX	1.5-V CMOS output	USB-Blaster II JTAG receive LED
JTAG_TX	1.5-V CMOS output	USB-Blaster II JTAG transmit LED
C_JTAG_TCK	2.5-V CMOS output	GPIO for on-board JTAG chain clock
C_JTAG_TMS	2.5-V CMOS output	GPIO for on-board JTAG chain mode
C_JTAG_TDI	2.5-V CMOS output	GPIO for on-board JTAG chain data in
C_JTAG_TDO	2.5-V CMOS input	GPIO for on-board JTAG chain data out
USB_CLK	1.5-V CMOS input	USB System Console clock
USB_OEn	1.5-V CMOS input	USB System Console FPGA output enable
USB_RESETn	1.5-V CMOS input	USB System Console reset
USB_DATA(7:0)	1.5-V CMOS inout (8 bits)	USB System Console FIFO data bus
USB_RDn	1.5-V CMOS input	USB System Console read from FIFO
USB_WRn	1.5-V CMOS input	USB System Console write to FIFO
USB_EMPTY	1.5-V CMOS output	USB System Console FIFO empty
USB_FULL	1.5-V CMOS output	USB System Console FIFO full
USB_ADDR(1:0)	1.5-V CMOS input/output	USB System Console address bus
USB_SCL	1.5-V CMOS input/output	USB System Console configuration clock
USB_SDA	1.5-V CMOS input/output	USB System Console configuration data
FACTORY_REQUEST	1.5-V CMOS input	Send FACTORY command
FACTORY_STATUS	1.5-V CMOS output	FACTORY command status
M570_CLOCK	1.5-V CMOS input	25-MHz input clock for FACTORY command

JTAG Chain

The on-board USB-Blaster II is automatically disabled when you connect an external USB-Blaster to the JTAG chain or when you enable JTAG from the PCI Express edge connector. [Figure 2-3](#) illustrates the JTAG chain.

Figure 2-3. JTAG Chain

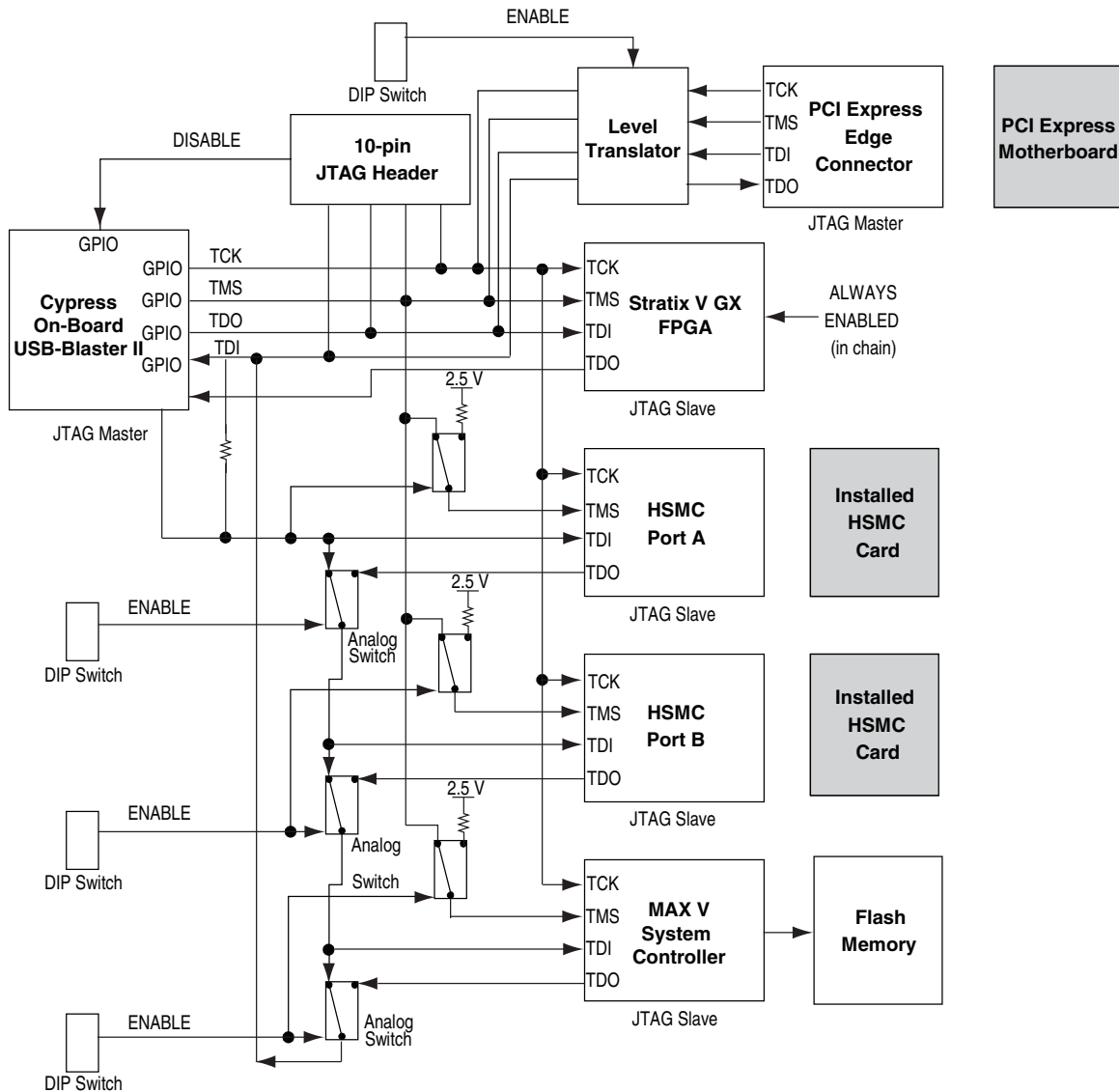

Each jumper shown in [Figure 2-3](#) is located in the JTAG DIP switch (SW3) on the back of the board. To connect a device or interface in the chain, their corresponding switch must be in the OFF position. Push all the switches in the ON position to only have the FPGA in the chain. Note that the MAX V CPLD System Controller must be in the chain to use some of the GUI interfaces.

 By default, the on-board USB-Blaster II clocks TCK at 24 MHz. For the on-board USB-Blaster II to function correctly, you must set the Quartus II clock constraint on the `internal_tck` input signal to 24 MHz.

System Console USB Interface

The System Console USB interface is a fast parallel interface. Together with the soft logic supplied by Altera, this interface provides a System Console master for debug access.

The System Console controls the debug master via signals shown in Table 2-8 to give fast access to an Avalon® Memory-Mapped (Avalon-MM) master bus that the Qsys system integration tool generates.

 For more information about the System Console, refer to the *Analyzing and Debugging Designs with the System Console* chapter in volume 3 of the *Quartus II Handbook*.

Table 2-8 lists the System Console USB interface pin connections relative to the FPGA.

Table 2-8. System Console USB Interface Pin Connections

Stratix V GX FPGA Device Pin Number	Schematic Signal Name	Direction	Note
AV28	usb_clk	input	48 MHz
H34	usb_reset_n	input	—
G32, G33, F32, E32, A37, A36, C34, A35	usb_data[7:0]	bidirectional	G32(MSB), A35 (LSB)
N34	usb_full	output	—
P34	usb_empty	output	—
J33	usb_wr_n	input	—
K33	usb_rd_n	input	—
E33	usb_oe_n	input	—
G34, K34	usb_addr	bidirectional	Reserved
J34	usb_scl	bidirectional	—
F33	usb_sda	bidirectional	—

Flash Programming

Flash programming is possible through a variety of methods using the Stratix V GX FPGA device.

The first method is to use the factory design called the Board Update Portal. This design is an embedded webserver, which serves the Board Update Portal web page. The web page allows you to select new FPGA designs including hardware, software, or both in an industry-standard S-Record File (**.flash**) and write the design to the user hardware page (page 1) of the flash over the network.

The secondary method is to use the pre-built PFL design included in the development kit. The development board implements the Altera PFL megafunction for flash programming. The PFL megafunction is a block of logic that is programmed into an Altera programmable logic device (FPGA or CPLD). The PFL functions as a utility for writing to a compatible flash device. This pre-built design contains the PFL megafunction that allows you to write either page 0, page 1, or other areas of flash over the USB interface using the Quartus II software. Use this method to restore the development board to its factory default settings.

Other methods to program the flash can be used as well, including the Nios II processor.

- For more information on the Nios II processor, refer to the [Nios II Processor](#) page of the Altera website.

FPGA Programming from Flash Memory

On either power-up or by pressing the program load push button (S2), the MAX V CPLD System Controller's parallel flash loader configures the FPGA from the flash memory. The system controller uses the Altera Parallel Flash Loader (PFL) megafunction which reads 32-bit data from the flash memory and converts it to fast passive parallel (FPP) format. This 32-bit data is then written to the FPGA's dedicated configuration pins during configuration.

Table 2-9 lists the configuration status LEDs settings.

Table 2-9. Configuration LED settings (Note 1)

LED			Design
PGM_LED0	PGM_LED1	PGM_LED2	
✓	—	—	Factory
—	✓	—	User design 1
—	—	✓	User design 2

Note to Table 2-9:
(1) A checkmark (✓) indicates that the LED is ON (logic 0) while a dash (—) indicates that the LED is OFF (logic 1).

Figure 2-4 shows the PFL configuration.

Figure 2-4. PFL Configuration

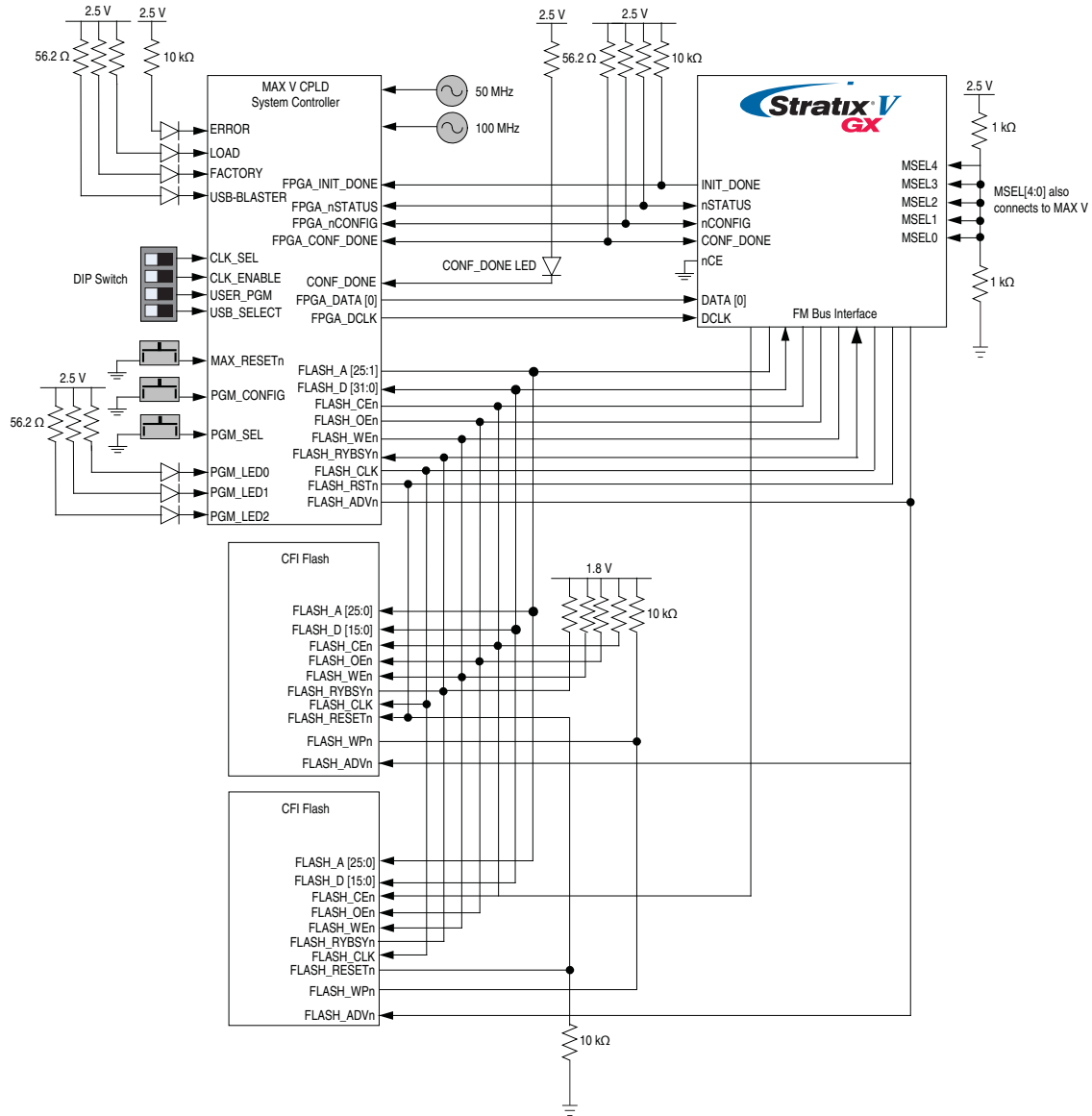

For more information on the flash memory map storage, refer to the *Stratix V GX FPGA Development Kit User Guide*.

FPGA Programming over External USB-Blaster

The JTAG programming header provides another method for configuring the FPGA (U15) using an external USB-Blaster device with the Quartus II Programmer running on a PC. The external USB-Blaster connects to the board through the JTAG header (J10).

 For more information on the following topics, refer to the respective documents:

- Board Update Portal and PFL Design, refer to the *Stratix V GX FPGA Development Kit User Guide*.
- PFL megafunction, refer to *AN 386: Using the Parallel Flash Loader with the Quartus II Software*.

Status Elements

The development board includes board-specific status LEDs and switches for enabling and configuring various features on the board, as well as a 16 character × 2 line LCD for displaying board power and temperature measurements. This section describes these status elements.

Status LEDs

Surface mount LEDs indicate the various status of the board. A logic 0 is driven on the I/O port to turn the LED on while a logic 1 is driven to turn the LED off.

Table 2–10 lists the LED board references, names, and functional descriptions.

Table 2–10. Board-Specific LEDs (Part 1 of 2)

Board Reference	LED Name	Schematic Signal Name	Description
D24	POWER	—	Blue LED. Illuminates when 5.0-V power is active.
D15	LOAD	MAX_LOAD	Green LED. Illuminates when the MAX V CPLD System Controller is actively configuring the FPGA. Driven by the MAX V CPLD System Controller.
D16	ERR	MAX_ERROR	Red LED. Illuminates when the MAX V CPLD System Controller fails to configure the FPGA. Driven by the MAX V CPLD System Controller.
D17	CONF DN	MAX_CONF_DONE	Green LED. Illuminates when the FPGA is successfully configured. Driven by the MAX V CPLD System Controller.
D29	TX	ENET_LED_TX	Green LED. Blinks to indicate Ethernet PHY transmit activity. Driven by the Marvell 88E1111 PHY.
D30	RX	ENET_LED_RX	Green LED. Blinks to indicate Ethernet PHY receive activity. Driven by the Marvell 88E1111 PHY.
D31	100	ENET_LED_LINK100	Green LED. Illuminates to indicate Ethernet linked at 100 Mbps connection speed. Driven by the Marvell 88E1111 PHY.
D32	1000	ENET_LED_LINK1000	Green LED. Illuminates to indicate Ethernet linked at 1000 Mbps connection speed. Driven by the Marvell 88E1111 PHY.
D1	HSMC Port A Present	HSMA_PRSENTN	Green LED. Illuminates when the HSMC port A has a board or cable plugged-in such that pin 160 becomes grounded. Driven by the add-in card.
D2	HSMC Port B Present	HSMB_PRSENTN	Green LED. Illuminates when the HSMC port B has a board or cable plugged-in such that pin 160 becomes grounded. Driven by the add-in card.

Table 2-10. Board-Specific LEDs (Part 2 of 2)

Board Reference	LED Name	Schematic Signal Name	Description
D4, D5, D6	PGM_LED	PGM_LED0 PGM_LED1 PGM_LED2	The sequence displayed determines if the factory design or a user design is used to configure the FPGA from flash when you press the PGM_LOAD push button. Refer to Table 2-9 for the push button configuration settings.
D12	TEMP	OVERTEMPn	Red LED. Illuminates when a heat sink or fan should be installed. Driven by the MAX1619 thermal sensor OVERTEMPn signal.

[Table 2-11](#) lists the board-specific LEDs component references and manufacturing information.

Table 2-11. Board-Specific LEDs Component References and Manufacturing Information

Board Reference	Description	Manufacturer	Manufacturer Part Number	Manufacturer Website
D1, D2, D4-D6, D15, D17, D29-D32	Green LEDs	Lumex Inc.	SML-LX1206GC-TR	www.lumex.com
D16	Red LED	Lumex Inc.	SML-LX1206USBC-TR	www.lumex.com
D24	Blue LED	Lumex Inc.	SML-LX1206USBC-TR	www.lumex.com

Setup Elements

The development board includes several different kinds of setup elements. This section describes the following setup elements:

- Board settings DIP switch
- JTAG control DIP switch
- PCI Express control DIP switch
- MAX V reset push button
- Program load push button
- Program select push button
- CPU reset push button

Board Settings DIP Switch

The board settings DIP switch (SW5) controls various features specific to the board and the MAX V CPLD System Controller logic design. [Table 2-12](#) lists the switch controls and descriptions.

Table 2-12. Board Settings DIP Switch Controls (Part 1 of 2)

Switch	Schematic Signal Name	Description	Default
1	CLK_SEL	ON : SMA input clock select. OFF : Programmable oscillator input clock select (default 100 MHz).	OFF
2	CLK_ENABLE	ON : On-Board oscillator enabled. OFF : On-Board oscillator disabled.	ON

Table 2–12. Board Settings DIP Switch Controls (Part 2 of 2)

Switch	Schematic Signal Name	Description	Default
3	FACTORY_LOAD	ON : Load user 1 design from flash at power up. OFF : Load factory design from flash at power up.	OFF
4	SECURITY_MODE	ON : Do not send FACTORY command at power-up. OFF : Send FACTORY command at power-up.	ON

Table 2–13 lists the board settings DIP switch component reference and manufacturing information.

Table 2–13. Board Settings DIP Switch Component Reference and Manufacturing Information

Board Reference	Description	Manufacturer	Manufacturer Part Number	Manufacturer Website
SW5	Four-Position slide DIP switch	C & K Components	TDA04H0SB1	www.ck-components.com

JTAG Control DIP Switch

The JTAG control DIP switch (SW3) provides you an option to either remove or include devices in the active JTAG chain. However, the Stratix V GX FPGA device is always in the JTAG chain. Table 2–14 shows the switch controls and its descriptions.

Table 2–14. JTAG Control DIP Switch Controls

Switch	Schematic Signal Name	Description	Default
1	5M2210_JTAG_EN	ON : Bypass MAX V CPLD System Controller. OFF : MAX V CPLD System Controller in-chain.	OFF
2	HSMA_JTAG_EN	ON : Bypass HSMC port A. OFF : HSMC port A in-chain.	ON
3	HSMB_JTAG_EN	ON : Bypass HSMC port B. OFF : HSMC port B in-chain.	ON
4	PCIE_JTAG_EN	ON : On-Board USB-Blaster II or external USB-Blaster is the chain master. OFF : PCI Express edge connector is the chain master.	ON

Table 2–15 lists the JTAG control DIP switch component references and manufacturing information.

Table 2–15. JTAG Control DIP Switch Component Reference and Manufacturing Information

Board Reference	Device Description	Manufacturer	Manufacturer Part Number	Manufacturer Website
SW3	Four-Position slide DIP switch	C & K Components	TDA04H0SB1	www.ck-components.com

PCI Express Control DIP Switch

The PCI Express control DIP switch (SW6) can enable or disable different configurations. Table 2-16 shows the switch controls and descriptions.

Table 2-16. PCI Express Control DIP Switch Controls

Switch	Schematic Signal Name	Description	Default
1	PCIE_PRSENT2n_x1	ON : Enable x1 presence detect OFF : Disable x1 presence detect	ON
2	PCIE_PRSENT2n_x4	ON : Enable x4 presence detect OFF : Disable x4 presence detect	ON
3	PCIE_PRSENT2n_x8	ON : Enable x8 presence detect OFF : Disable x8 presence detect	ON
4	—	Unused	—

Table 2-17 lists the PCI Express control DIP switch component reference and manufacturing information.

Table 2-17. PCI Express Control DIP Switch Component Reference and Manufacturing Information

Board Reference	Device Description	Manufacturer	Manufacturer Part Number	Manufacturer Website
SW6	Four-Position slide DIP switch	C & K Components	TDA04H0SB1	www.ck-components.com

MAX V Reset Push Button

The MAX V reset push button, MAX_RESETn, is an input to the MAX V CPLD System Controller. This push button is the default logic reset for the CPLD logic.

Table 2-19 lists the MAX V reset push button component reference and manufacturing information.

Table 2-18. MAX V Reset Push Button Component Reference and Manufacturing Information

Board Reference	Description	Manufacturer	Manufacturer Part Number	Manufacturer Website
S1	Push button	Dawning Precision Co., Ltd.	TS-A02SA-2-S100	www.dawning2.com.tw

Program Load Push Button

The program load push button, PGM_CONFIG, is an input to the MAX V CPLD System Controller. The push button forces a reconfiguration of the FPGA from flash memory. The location in the flash memory is based on the settings of the PGM_LED [2:0] which is controlled by the program select push button, PGM_SEL.

Table 2-19 lists the program load push button component reference and manufacturing information.

Table 2-19. Program Load Push Button Component Reference and Manufacturing Information

Board Reference	Description	Manufacturer	Manufacturer Part Number	Manufacturer Website
S2	Push button	Dawning Precision Co., Ltd.	TS-A02SA-2-S100	www.dawning2.com.tw

Program Select Push Button

The program select push button, PGM_SEL, is an input to the MAX V CPLD System Controller. The push button toggles the PGM_LED [2:0] setting that selects which location in the flash memory is used to configure the FPGA. Refer to Table 2-9 for the configuration settings.

Table 2-20 lists the program select push button component reference and manufacturing information.

Table 2-20. Program Select Push Button Component Reference and Manufacturing Information

Board Reference	Description	Manufacturer	Manufacturer Part Number	Manufacturer Website
S3	Push button	Dawning Precision Co., Ltd.	TS-A02SA-2-S100	www.dawning2.com.tw

CPU Reset Push Button

The CPU reset push button, CPU_RESETh, is an input to the Stratix V GX FPGA DEV_CLRn pin and is an open-drain I/O from the MAX V CPLD System Controller. This push button is the default logic reset for the FPGA logic. The MAX V System Controller also drives this push button during POR.

You must enable the CPU_RESETh signal within the Quartus II software for this reset function to work. Otherwise, the CPU_RESETh acts as a regular I/O pin. When you enable the signal in the Quartus II software, and then pulled high on the board, this push button resets every register within the FPGA with a low signal.

Table 2-21 lists the CPU reset push button component reference and manufacturing information.

Table 2-21. CPU Reset Configuration Push Button Component Reference and Manufacturing Information

Board Reference	Description	Manufacturer	Manufacturer Part Number	Manufacturer Website
S4	Push button	Dawning Precision Co., Ltd.	TS-A02SA-2-S100	www.dawning2.com.tw

Clock Circuitry

This section describes the board's clock inputs and outputs.

On-Board Oscillators

The development board includes a 50-MHz, 100-MHz, 125-MHz, and 156.25-MHz programmable oscillators. Figure 2-5 shows the default frequencies of all external clocks going to the Stratix V GX FPGA development board.

Figure 2-5. Stratix V GX FPGA Development Board External Clock Inputs and Default Frequencies

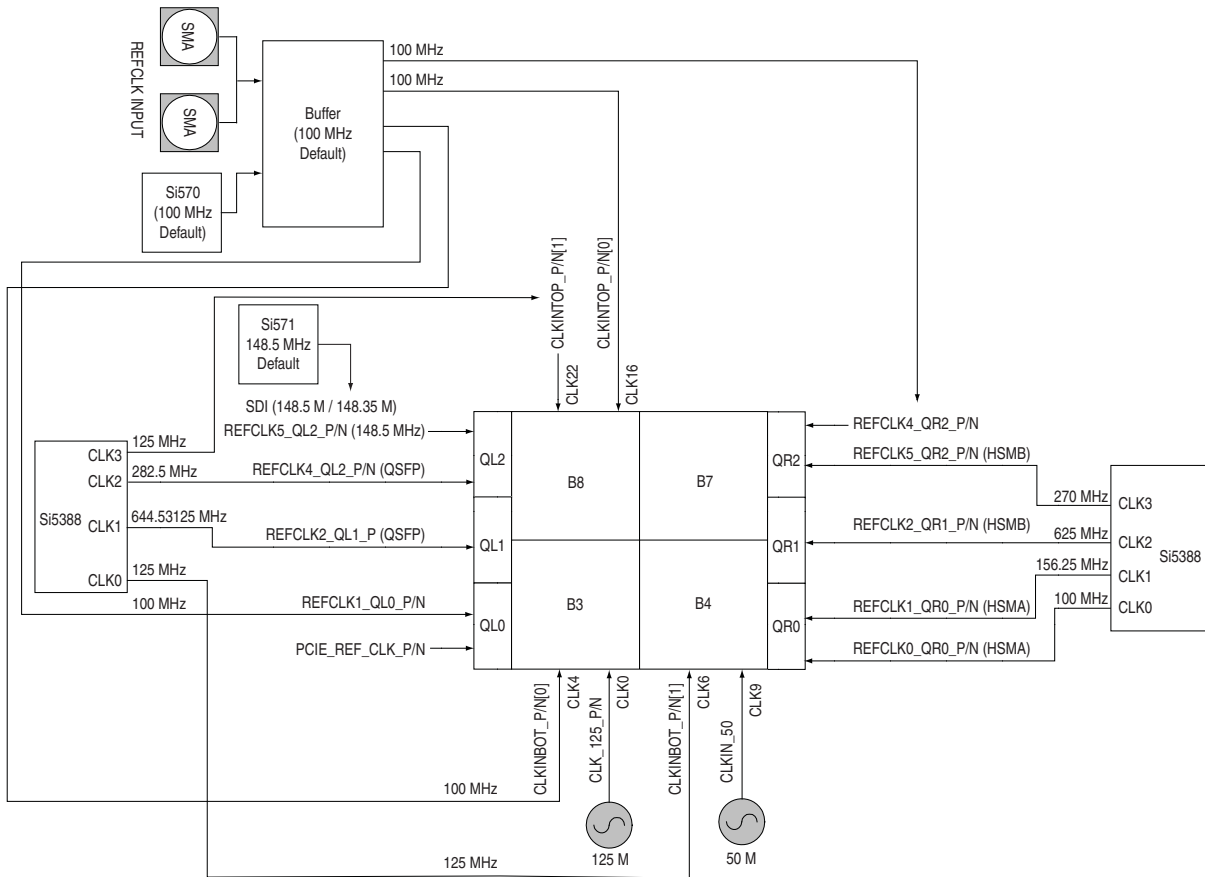

Table 2–22 lists the oscillators, its I/O standard, and voltages required for the development board.

Table 2–22. On-Board Oscillators

Source	Schematic Signal Name	Frequency	I/O Standard	Stratix V GX FPGA Device Pin Number	Application
X3	CLKIN_50	50.000 MHz	2.5V CMOS	AN6	Nios II and MAX V
X2	CLK_CONFIG	100.000 MHz	2.5V CMOS	—	Fast FPGA configuration
X4	REFCLK1_QL0_P	100.000 MHz	LVDS (fanout buffer)	AD33	PCI Express host/dual-XTL
	REFCLK1_QL0_N			AD34	
	CLKINBOT_P0			AH22	Bottom edge
	CLKINBOT_N0			AJ22	
	CLKINTOP_P0			J23	Top edge—DDR3
	CLKINTOP_N0			J24	
	REFCLK4_QR2_P			V6	HSMC port B
	REFCLK4_QR2_N			V5	
X1	CLK_125_P	125.000 MHz	LVDS	AV29	10/100/1000 Ethernet
	CLK_125_N		LVDS	AW29	
X6	REFCLK5_QL2_P	148.500 MHz	LVDS	T33	HD-SDI video
	REFCLK5_QL2_N		LVDS	T34	
U46	CLKINTOP_P1	125.000 MHz	LVDS	N32	Top edge
	CLKINTOP_N1		LVDS	M32	
	REFCLK4_QL2_P	282.500 MHz	LVDS	V34	QSFP
	REFCLK4_QL2_N		LVDS	V35	
	REFCLK2_QL1_P	644.53125 MHz	LVDS	AB35	
	REFCLK2_QL1_N		LVDS	AB34	
	CLKINBOT_P1	125.000 MHz	LVDS	AF17	Bottom edge—memory
CLKINBOT_N1	LVDS		AG17		
U38	REFCLK5_QR2_P	270.000 MHz	LVDS	T7	HSMC port B
	REFCLK5_QR2_N		LVDS	T6	
	REFCLK2_QR1_P	625.000 MHz	LVDS	AB6	
	REFCLK2_QR1_N		LVDS	AB5	
	REFCLK1_QR0_P	156.250 MHz	LVDS	AD7	XAUI, 10GbE, HSMC port A
	REFCLK1_QR0_N		LVDS	AD6	
	REFCLK0_QR0_P	100.000 MHz	LVDS	AF6	HSMC port A
	REFCLK0_QR0_N		LVDS	AF5	

Off-Board Clock Input/Output

The development board has input and output clocks which can be driven onto the board. The output clocks can be programmed to different levels and I/O standards according to the FPGA device's specification.

Table 2-23 lists the clock inputs for the development board.

Table 2-23. Off-Board Clock Inputs

Source	Schematic Signal Name	I/O Standard	Stratix V GX FPGA Device Pin Number	Description
SMA	CLKIN_SMA_P	LVPECL	—	Input to LVDS fan-out buffer (drives one REFCLK)
	CLKIN_SMA_N	LVPECL	—	
Samtec HSMC	HSMA_CLK_IN0	2.5-V	AG28	Single-ended input from the installed HSMC cable or board.
Samtec HSMC	HSMA_CLK_IN_P1	LVDS/2.5-V	AR8	LVDS input from the installed HSMC cable or board. Can also support 2x LVTTTL inputs.
	HSMA_CLK_IN_N1	LVDS/LVTTTL	AT8	
Samtec HSMC	HSMA_CLK_IN_P2	LVDS/LVTTTL	G7	LVDS input from the installed HSMC cable or board. Can also support 2x LVTTTL inputs.
	HSMA_CLK_IN_N2	LVDS/LVTTTL	G6	
Samtec HSMC	HSMB_CLK_IN0	2.5-V	AF29	Single-ended input from the installed HSMC cable or board.
Samtec HSMC	HSMB_CLK_IN_P1	LVDS/LVTTTL	U15	LVDS input from the installed HSMC cable or board. Can also support 2x LVTTTL inputs.
	HSMB_CLK_IN_N1	LVDS/LVTTTL	T16	
Samtec HSMC	HSMB_CLK_IN_P2	LVDS/LVTTTL	P16	LVDS input from the installed HSMC cable or board. Can also support 2x LVTTTL inputs.
	HSMB_CLK_IN_N2	LVDS/LVTTTL	N16	
PCI Express Edge	PCIE_REFCLK_P	LVDS/LVTTTL	AF34	LVDS input from the PCI Express edge connector.
	PCIE_REFCLK_N	HCSL	AF35	

Table 2-24 lists the clock outputs for the development board.

Table 2-24. Off-Board Clock Outputs

Source	Schematic Signal Name	I/O Standard	Stratix V GX FPGA Device Pin Number	Description
Samtec HSMC	HSMA_CLK_OUT0	2.5V CMOS	AJ10	FPGA CMOS output (or GPIO)
Samtec HSMC	HSMA_CLK_OUT_P1	LVDS/2.5V CMOS	AG9	LVDS output. Can also support 2x CMOS outputs.
	HSMA_CLK_OUT_N1	LVDS/2.5V CMOS	AH9	
Samtec HSMC	HSMA_CLK_OUT_P2	LVDS/2.5V CMOS	G9	LVDS output. Can also support 2x CMOS outputs.
	HSMA_CLK_OUT_N2	LVDS/2.5V CMOS	G8	
Samtec HSMC	HSMB_CLK_OUT0	2.5V CMOS	L16	FPGA CMOS output (or GPIO)
Samtec HSMC	HSMB_CLK_OUT_P1	LVDS/2.5V CMOS	D16	LVDS output. Can also support 2x CMOS outputs.
	HSMB_CLK_OUT_N1	LVDS/2.5V CMOS	C16	
Samtec HSMC	HSMB_CLK_OUT_P2	LVDS/2.5V CMOS	B16	LVDS output. Can also support 2x CMOS outputs.
	HSMB_CLK_OUT_N2	LVDS/2.5V CMOS	A16	

Memory Clocks

The development board includes memory clocks which are driven to or received from the on-board memory devices. For more information on the memory clock signals, refer to the section on “Memory” on page 2-46.

Table 2-25 lists the crystal oscillators component references and manufacturing information.

Table 2-25. Crystal Oscillator Component References and Manufacturing Information

Board Reference	Description	Manufacturer	Manufacturer Part Number	Manufacturer Website
X1	148.50 MHz LVDS voltage controlled crystal oscillator	Epson	EG-2121CA 125.0000M-LGPNL3	www.eea.epson.com
X2	100 MHz 2.5-V CMOS oscillator	ECS, Inc.	ECS-3525-1000-B-TR	www.ecsxtal.com
X3	50 MHz 1.8-V oscillator	ECS, Inc.	ECS-3518-500-B-xx	www.ecsxtal.com
X4	100.00 MHz LVDS programmable crystal oscillator	Silicon Labs	570FAB000433DG	www.silabs.com
X6	125 MHz LVDS saw oscillator	Silicon Labs	571FDB000159DG	www.silabs.com
U38	Programmable LVDS quad-clock 100M, 156.25M, 625M, 270M defaults	Silicon Labs	Si5338A-A01086-GM	www.silabs.com
U46	Programmable LVDS quad-clock 125M, 644.53125M, 282.5M, 125M defaults	Silicon Labs	Si5338A-A01085-GM	www.silabs.com

General User Input/Output

This section describes the user I/O interface to the FPGA. This section describes the following I/O elements:

- User-defined push buttons
- User-defined DIP switch
- User-defined LEDs
- Character LCD

User-Defined Push Buttons

The development board includes three user-defined push buttons. Board references S5, S6, and S7 are push buttons that allow you to interact with the Stratix V GX FPGA device. When you press and hold down the push button, the device pin is set to logic 0; when you release the push button, the device pin is set to logic 1. There is no board-specific function for these general user push buttons.

Table 2-26 lists the user-defined push button schematic signal names and their corresponding Stratix V GX FPGA device pin numbers.

Table 2-26. User-Defined Push Button Schematic Signal Names and Functions

Board Reference	Schematic Signal Name	I/O Standard	Stratix V GX FPGA Device Pin Number	Description
S5	USER_PB2	2.5-V (Variable S5_VCCIO_HSMB)	A7	User-Defined push buttons
S6	USER_PB1		B7	
S7	USER_PB0		C7	

Table 2-27 lists the user-defined push button component reference and the manufacturing information.

Table 2-27. User-Defined Push Button Component Reference and Manufacturing Information

Board Reference	Description	Manufacturer	Manufacturer Part Number	Manufacturer Website
S5, S6, S7	Push button	Dawning Precision Co., Ltd.	TS-A02SA-2-S100	www.dawning2.com.tw

User-Defined DIP Switches

Board reference SW1 is an 8-pin DIP switch. The switches are user-defined, and are for additional FPGA input control. There is no board-specific function for these switches.

Table 2-28 lists the user-defined DIP switch schematic signal names and their corresponding Stratix V GX FPGA pin numbers.

Table 2-28. User-Defined DIP Switch Schematic Signal Names and Functions

Board Reference (SW1)	Schematic Signal Name	I/O Standard	Stratix V GX FPGA Device Pin Number	Description
1	USER_DIPSW0	2.5-V (Variable S5_VCCIO_HSMB)	E7	User-Defined DIP switch connected to FPGA device. When the switch is in the CLOSED or ON position, a logic 0 is selected. When the switch is in the OPEN or OFF position, a logic 1 is selected.
2	USER_DIPSW1		H7	
3	USER_DIPSW2		J7	
4	USER_DIPSW3		K7	
5	USER_DIPSW4		M6	
6	USER_DIPSW5		N6	
7	USER_DIPSW6		P7	
8	USER_DIPSW7		N7	

Table 2-29 lists the user-defined DIP switch component reference and the manufacturing information.

Table 2-29. User-Defined DIP Switch Component Reference and Manufacturing Information

Board Reference	Description	Manufacturer	Manufacturer Part Number	Manufacturer Website
SW1	Eight-Position DIP switch	C & K Components	TDA08H0SB1	www.ck-components.com

User-Defined LEDs

The development board includes general and HSMC user-defined LEDs. This section describes all user-defined LEDs. For information on board specific or status LEDs, refer to “[Status Elements](#)” on page 2-18.

General User-Defined LEDs

Board references D7 through D10 and D18 through D21 are eight bi-color user LEDs which allow status and debugging signals to be driven to the LEDs from the designs loaded into the Stratix V GX FPGA device. These bi-color LEDs are in red and green, which combines to a total of 16 unique user LEDs. The LEDs illuminate when a logic 0 is driven, and turns off when a logic 1 is driven. There is no board-specific function for these LEDs.

[Table 2-30](#) lists the user-defined LED schematic signal names and their corresponding Stratix V GX FPGA pin numbers.

Table 2-30. User-Defined LED Schematic Signal Names and Functions

Board Reference	Schematic Signal Name	I/O Standard	Stratix V GX FPGA Device Pin Number	Description
D21.3	USER_LED_G0	2.5-V	J11	User-Defined LEDs. Driving a logic 0 on the I/O port turns the LED ON. Driving a logic 1 on the I/O port turns the LED OFF.
D20.3	USER_LED_G1	2.5-V	U10	
D19.3	USER_LED_G2	2.5-V	U9	
D18.3	USER_LED_G3	1.8-V	AU24	
D10.3	USER_LED_G4	2.5-V	AF28	
D9.3	USER_LED_G5	2.5-V	AE29	
D8.3	USER_LED_G6	1.8-V	AR7	
D7.3	USER_LED_G7	2.5-V	AV10	
D21.4	USER_LED_R0	2.5-V	AH28	
D20.4	USER_LED_R1	2.5-V	AG30	
D19.4	USER_LED_R2	1.8-V	AL7	
D18.4	USER_LED_R3	1.8-V	AR24	
D10.4	USER_LED_R4	1.8-V	AM7	
D9.4	USER_LED_R5	1.8-V	AW7	
D8.4	USER_LED_R6	1.8-V	AL23	
D7.4	USER_LED_R7	1.8-V	AV7	

[Table 2-31](#) lists the user-defined LED component reference and the manufacturing information.

Table 2-31. User-Defined LED Component Reference and Manufacturing Information

Board Reference	Device Description	Manufacturer	Manufacturer Part Number	Manufacturer Website
D7-D10, D18-D21	Bi-color green/red LEDs, 0606, SMT, Clear Lens, 2.1/2.0 V	Lite-On, Inc.	LTST-C195GEKT	www.us.liteon.com

HSMC User-Defined LEDs

The HSMC port A and B have two LEDs located nearby. The LEDs are labeled TX and RX. The LEDs display data flow to and from the connected HSMC cards. The LEDs are driven by the Stratix V GX FPGA device. There are no board-specific functions for the HSMC LEDs.

Table 2–32 lists the HSMC user-defined LED schematic signal names and their corresponding Stratix V GX FPGA pin numbers.

Table 2–32. HSMC User-Defined LED Schematic Signal Names and Functions

Board Reference	Schematic Signal Name	I/O Standard	Stratix V GX FPGA Device Pin Number	Description
D3	HSMA_TX_LED	1.8-V	AU8	User-Defined LEDs. Labeled TX for HSMC Port A.
D13	HSMA_RX_LED	1.8-V	AV8	User-Defined LEDs. Labeled RX for HSMC Port A.
D11	HSMB_TX_LED	1.8-V	AP6	User-Defined LEDs. Labeled TX for HSMC Port B.
D14	HSMB_RX_LED	1.8-V	AR6	User-Defined LEDs. Labeled RX for HSMC Port B.

Table 2–33 lists the HSMC user-defined LED component reference and the manufacturing information.

Table 2–33. HSMC User-Defined LED Component Reference and Manufacturing Information

Board Reference	Description	Manufacturer	Manufacturer Part Number	Manufacturer Website
D3, D11, D13, D14	Green LEDs, 0805, SMT, 2.0 V	Lumex Inc.	SML-LXT0805GW-TR	www.lumex.com

Character LCD

The development board contains a single 14-pin 0.1" pitch dual-row header that interfaces to a 16 character × 2 line Lumex LCD display. The LCD has a 14-pin receptacle that mounts directly to the board's 14-pin header, so you can easily remove it to access components under the display. You can also use the header for debugging or other purposes.

Table 2–34 summarizes the LCD pin assignments. The signal names and directions are relative to the Stratix V GX FPGA.

Table 2–34. LCD Pin Assignments, Schematic Signal Names, and Functions

Board Reference (J15)	Schematic Signal Name	I/O Standard	Stratix V GX FPGA Device Pin Number	Description
4	LCD_D_Cn	2.5-V	AH10	LCD data or command select
5	LCD_WEn	2.5-V	AW10	LCD write enable
6	LCD_CSn	2.5-V	AU9	LCD chip select
7	LCD_DATA0	2.5-V	AP10	LCD data bus
8	LCD_DATA1	2.5-V	AN10	LCD data bus
9	LCD_DATA2	2.5-V	AM10	LCD data bus

Table 2-34. LCD Pin Assignments, Schematic Signal Names, and Functions

Board Reference (J15)	Schematic Signal Name	I/O Standard	Stratix V GX FPGA Device Pin Number	Description
10	LCD_DATA3	2.5-V	AL10	LCD data bus
11	LCD_DATA4	2.5-V	AP9	LCD data bus
12	LCD_DATA5	2.5-V	AN9	LCD data bus
13	LCD_DATA6	2.5-V	AT9	LCD data bus
14	LCD_DATA7	2.5-V	AR9	LCD data bus

Table 2-35 shows the LCD pin definitions, and is an excerpt from the Lumex data sheet.

 For more information such as timing, character maps, interface guidelines, and other related documentation, visit www.lumex.com.

Table 2-35. LCD Pin Definitions and Functions

Pin Number	Symbol	Level	Function
1	V _{DD}	—	Power supply
2	V _{SS}	—	
3	V ₀	—	
4	RS	H/L	Register select signal H: Data input L: Instruction input
5	R/W	H/L	H: Data read (module to MPU) L: Data write (MPU to module)
6	E	H, H to L	Enable
7-14	DB0-DB7	H/L	Data bus, software selectable 4-bit or 8-bit mode

 The particular model used does not have a backlight and the LCD drive pin is connected to 5 V for maximum pixel drive.

Table 2-36 lists the LCD component references and the manufacturing information.

Table 2-36. LCD Component References and Manufacturing Information

Board Reference	Description	Manufacturer	Manufacturer Part Number	Manufacturer Website
J15	2×7 pin, 100 mil, vertical header	Samtec	SSW-107-01-G-D	www.samtec.com
	2×16 character display, 5×8 dot matrix	Lumex Inc.	LCM-S01602DSR/C	www.lumex.com

Components and Interfaces

This section describes the development board's communication ports and interface cards relative to the Stratix V GX FPGA device. The development board supports the following communication ports:

- PCI Express
- 10/100/1000 Ethernet
- HSMC
- SDI Video Output
- 40G QSFP Module

PCI Express

The Stratix V GX FPGA development board is designed to fit entirely into a PC motherboard with a ×8 PCI Express slot that can accommodate a full height short form factor add-in card. This interface uses the Stratix V GX FPGA device's PCI Express hard IP block, saving logic resources for the user logic application.



For more information on using the PCI Express hard IP block, refer to the *IP Compiler for PCI Express User Guide*.

The PCI Express interface supports auto-negotiating channel width from ×1 to ×4 to ×8 as well as the connection speed of Gen1 at 2.5 Gbps/lane, Gen2 at 5.0 Gbps/lane, or Gen3 at 8.0 Gbps/lane for a maximum of 64 Gbps full-duplex bandwidth.

The power for the board can be sourced entirely from the PCI Express edge connector when installed into a PC motherboard. Although the board can also be powered by a laptop power supply for use on a lab bench, it is not recommended to power from both supplies at the same time. Ideal diode power sharing devices have been designed into this board to prevent damages or back-current from one supply to the other.

The PCIE_REFCLK_P/N signal is a 100-MHz differential input that is driven from the PC motherboard to the board through the PCI Express edge connector. This signal connects directly to a Stratix V GX FPGA REFCLK input pin pair using DC coupling. This clock is terminated on the motherboard and therefore, no on-board termination is required. This clock can have spread-spectrum properties that change its period between 9.847 ps to 10.203 ps. The I/O standard is High-Speed Current Steering Logic (HCSL).

Figure 2-6 shows the PCI Express reference clock levels.

Figure 2-6. PCI Express Reference Clock Levels

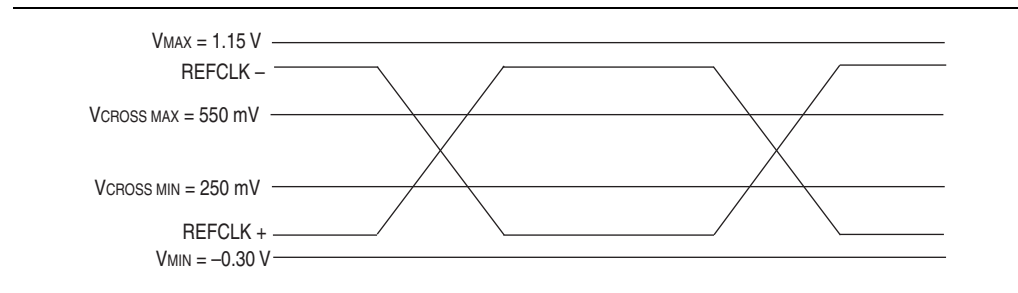

The SMB and JTAG are optional signals in the PCI Express specification. The SMB signals are wired to the Stratix V GX FPGA device and the JTAG signals control the JTAG chain if enabled by the JTAG control DIP switch (SW3.4). The PCI Express control DIP switch allows the presence detect grounding to be altered to enable a $\times 1$, $\times 4$, or $\times 8$ width edge connector. The PCI Express control DIP switch does not support auto-negotiation.

The PCI Express edge connector also has a presence detect feature to allow the motherboard to determine if a card is installed. A jumper is provided to optionally connect PRSNT1n to any of the 3 PRSNT2n pins found within the $\times 8$ connector definition. This is to address issues on some PC systems that would base the link-width capability on the presence detect pins versus a query operation.

Table 2-37 summarizes the PCI Express pin assignments. The signal names and directions are relative to the Stratix V GX FPGA.

Table 2-37. PCI Express Pin Assignments, Schematic Signal Names, and Functions (Part 1 of 2)

Board Reference (J18)	Schematic Signal Name	I/O Standard	Stratix V GX FPGA Device Pin Number	Description
B14	PCIE_RX_P0	1.4-V PCML	AV38	Receive bus
B15	PCIE_RX_N0	1.4-V PCML	AV39	Receive bus
B19	PCIE_RX_P1	1.4-V PCML	AT38	Receive bus
B20	PCIE_RX_N1	1.4-V PCML	AT39	Receive bus
B23	PCIE_RX_P2	1.4-V PCML	AP38	Receive bus
B24	PCIE_RX_N2	1.4-V PCML	AP39	Receive bus
B27	PCIE_RX_P3	1.4-V PCML	AM38	Receive bus
B28	PCIE_RX_N3	1.4-V PCML	AM39	Receive bus
B33	PCIE_RX_P4	1.4-V PCML	AH38	Receive bus
B34	PCIE_RX_N4	1.4-V PCML	AH39	Receive bus
B37	PCIE_RX_P5	1.4-V PCML	AF38	Receive bus
B38	PCIE_RX_N5	1.4-V PCML	AF39	Receive bus
B41	PCIE_RX_P6	1.4-V PCML	AD38	Receive bus
B42	PCIE_RX_N6	1.4-V PCML	AD39	Receive bus
B45	PCIE_RX_P7	1.4-V PCML	AB38	Receive bus
B46	PCIE_RX_N7	1.4-V PCML	AB39	Receive bus

Table 2-37. PCI Express Pin Assignments, Schematic Signal Names, and Functions (Part 2 of 2)

Board Reference (J18)	Schematic Signal Name	I/O Standard	Stratix V GX FPGA Device Pin Number	Description
A16	PCIE_TX_P0	1.4-V PCML	AU36	Transmit bus
A17	PCIE_TX_N0	1.4-V PCML	AU37	Transmit bus
A21	PCIE_TX_P1	1.4-V PCML	AR36	Transmit bus
A22	PCIE_TX_N1	1.4-V PCML	AR37	Transmit bus
A25	PCIE_TX_P2	1.4-V PCML	AN36	Transmit bus
A26	PCIE_TX_N2	1.4-V PCML	AN37	Transmit bus
A29	PCIE_TX_P3	1.4-V PCML	AL36	Transmit bus
A30	PCIE_TX_N3	1.4-V PCML	AL37	Transmit bus
A35	PCIE_TX_P4	1.4-V PCML	AG36	Transmit bus
A36	PCIE_TX_N4	1.4-V PCML	AG37	Transmit bus
A39	PCIE_TX_P5	1.4-V PCML	AE36	Transmit bus
A40	PCIE_TX_N5	1.4-V PCML	AE37	Transmit bus
A43	PCIE_TX_P6	1.4-V PCML	AC36	Transmit bus
A44	PCIE_TX_N6	1.4-V PCML	AC37	Transmit bus
A47	PCIE_TX_P7	1.4-V PCML	AA36	Transmit bus
A48	PCIE_TX_N7	1.4-V PCML	AA37	Transmit bus
A5	PCIE_JTAG_TCK	1.4-V PCML	—	JTAG chain clock
A6	PCIE_JTAG_TDI	1.4-V PCML	—	JTAG chain data in
A7	PCIE_JTAG_TDO	1.4-V PCML	—	JTAG chain data out
A8	PCIE_JTAG_TMS	1.4-V PCML	—	JTAG chain mode select
A1	PCIE_PRSENT1N	LVTTTL	—	Presence detect DIP switch
B17	PCIE_PRSENT2N_X1	LVTTTL	—	Presence detect DIP switch
B31	PCIE_PRSENT2N_X4	LVTTTL	—	Presence detect DIP switch
B48	PCIE_PRSENT2N_X8	LVTTTL	—	Presence detect DIP switch
A14	PCIE_REFCLK_N	HCSL	AF35	Motherboard reference clock
A13	PCIE_REFCLK_P	HCSL	AF34	Motherboard reference clock
B5	PCIE_SMBCLK	LVTTTL	AN33	SMB clock
B6	PCIE_SMBDAT	LVTTTL	AL34	SMB data
B11	PCIE_WAKEN_R	LVTTTL	AN32	Wake signal
A11	PCIE_PERSTN	LVTTTL	AC28	Reset

10/100/1000 Ethernet

The development board supports a 10/100/1000 BASE-T Ethernet connection using a Marvell 88E1111 PHY device and the Altera Triple-Speed Ethernet MegaCore MAC function. The device is an auto-negotiating Ethernet PHY with an SGMII interface to the FPGA. The Stratix V GX FPGA device can communicate with the LVDS interfaces at up to 1.25 Gbps. The MAC function must be provided in the FPGA for typical networking applications. The Marvell 88E1111 PHY uses 2.5-V and 1.0-V power rails and requires a 25-MHz reference clock driven from a dedicated oscillator. It interfaces to an RJ-45 with internal magnetics that can be used for driving copper lines with Ethernet traffic.

Figure 2-7 shows the SGMII interface between the FPGA (MAC) and Marvell 88E1111 PHY.

Figure 2-7. SGMII Interface between FPGA (MAC) and Marvell 88E1111 PHY

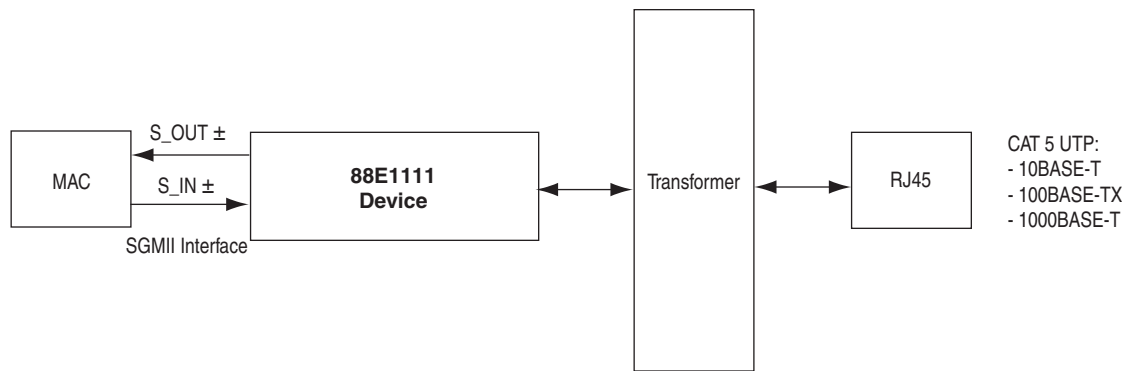

Table 2-38 lists the Ethernet PHY interface pin assignments.

Table 2-38. Ethernet PHY Pin Assignments, Signal Names and Functions

Board Reference (U19)	Schematic Signal Name	I/O Standard	Stratix V GX FPGA Device Pin Number	Description
82	ENET_TX_P	LVDS	AB27	SGMII transmit
81	ENET_TX_N	LVDS	AC27	SGMII transmit
77	ENET_RX_P	LVDS	AP34	SGMII receive
75	ENET_RX_N	LVDS	AR34	SGMII receive
28	ENET_RESETn	2.5-V	AA28	Device reset
25	ENET_MDC	2.5-V	AA26	Management bus data clock
24	ENET_MDIO	2.5-V	AA27	Management bus data
23	ENET_INTn	2.5-V	AA29	Management bus Interrupt
74	ENET_LED_LINK100	2.5-V	—	100-Mb link LED
73	ENET_LED_LINK1000	2.5-V	—	1000-Mb link LED
69	ENET_LED_RX	2.5-V	—	RX data active LED
68	ENET_LED_TX	2.5-V	—	TX data active LED

Table 2-39 lists the Ethernet PHY interface component reference and manufacturing information.

Table 2-39. Ethernet PHY Component Reference and Manufacturing Information

Board Reference	Description	Manufacturer	Manufacturing Part Number	Manufacturer Website
U19	Ethernet PHY BASE-T device	Marvel Semiconductor	88E1111-B2-CAAIC000	www.marvell.com

High-Speed Mezzanine Cards (HSMC)

The development board contains two HSMC interfaces—port A and port B—to provide 8 channels in port A and 4 channels in port B of 12.5 Gbps-capable transceivers. Port A supports a full SPI4.2 interface (17 LVDS channels) and 3 input and output clocks as well as SMBus and JTAG signals. The LVDS channels can be used for CMOS signaling as well as LVDS. For Port B, other than the 3 input and output clocks as well as SMBus and JTAG signals, it also covers the new DQS standard to support daughtercards with external memory devices. For memory support, the VCCIO banks for the HSMC port B is adjustable between 1.2 V, 1.5 V, 1.8 V, and 2.5 V. When the DQS features are not used, these channels can be used for CMOS signaling.

The HSMC port A interface supports both single-ended and differential signaling. The HSMC is an Altera-developed open specification, which allows you to expand the functionality of the development board through the addition of daughtercards. The HSMC port B is a new DQS standard to support both single-ended signaling and external memory interfaces.



For more information about the HSMC specification such as signaling standards, signal integrity, compatible connectors, cabling solutions, and mechanical information, refer to the *High Speed Mezzanine Card (HSMC) Specification* manual.

The HSMC connector has a total of 172 pins, including 120 signal pins, 39 power pins, and 13 ground pins. The ground pins are located between the two rows of signal and power pins, acting both as a shield and a reference. The HSMC host connector is based on the 0.5 mm-pitch QSH/QTH family of high-speed, board-to-board connectors from Samtec. There are three banks in this connector. Bank 1 has every third pin removed as done in the QSH-DP/QTH-DP series. Bank 2 and bank 3 have all the pins populated as done in the QSH/QTH series.

Figure 2-8 shows the bank arrangement of signals with respect to the Samtec connector's three banks.

Figure 2-8. HSMC Signal and Bank Diagram

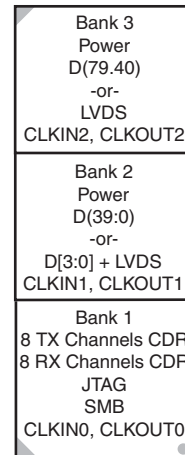

The HSMC interface has programmable bi-directional I/O pins that can be used as 2.5-V LVCMOS, which is 3.3-V LVTTTL-compatible. You can also use these pins as various differential I/O standards including, but not limited to, LVDS, mini-LVDS, and RSDS with up to 17 full-duplex channels.

 As noted in the *High Speed Mezzanine Card (HSMC) Specification* manual, LVDS and single-ended I/O standards are only guaranteed to function when mixed according to either the generic single-ended pin-out or generic differential pin-out.

Table 2-40 lists the HSMC port A interface pin assignments, signal names, and functions.

Table 2-40. HSMC Port A Pin Assignments, Schematic Signal Names, and Functions (Part 1 of 4)

Board Reference (J1)	Schematic Signal Name	I/O Standard	Stratix V GX FPGA Device Pin Number	Description
40	HSMA_CLK_IN0	LVDS or 2.5-V	AG28	Primary single-ended clock in
98	HSMA_CLK_IN_N1	LVDS or 2.5-V	AT8	LVDS or CMOS clock in 1
158	HSMA_CLK_IN_N2	LVDS or 2.5-V	G6	LVDS or CMOS clock in 2
96	HSMA_CLK_IN_P1	LVDS or 2.5-V	AR8	Secondary differential clock in
156	HSMA_CLK_IN_P2	LVDS or 2.5-V	G7	Primary source-synchronous clock in
39	HSMA_CLK_OUT0	LVDS or 2.5-V	AJ10	Primary single-ended clock out
97	HSMA_CLK_OUT_N1	LVDS or 2.5-V	AH9	LVDS or CMOS clock out 1
157	HSMA_CLK_OUT_N2	LVDS or 2.5-V	G8	LVDS or CMOS clock out 2
95	HSMA_CLK_OUT_P1	LVDS or 2.5-V	AG9	Secondary differential clock out
155	HSMA_CLK_OUT_P2	LVDS or 2.5-V	G9	Primary source-synchronous clock out
30	HSMA_RX_P0	1.4-V PCML	AV2	Transceiver receive channel
32	HSMA_RX_N0	1.4-V PCML	AV1	Transceiver receive channel

Table 2-40. HSMC Port A Pin Assignments, Schematic Signal Names, and Functions (Part 2 of 4)

Board Reference (J1)	Schematic Signal Name	I/O Standard	Stratix V GX FPGA Device Pin Number	Description
26	HSMA_RX_P1	1.4-V PCML	AP2	Transceiver receive channel
28	HSMA_RX_N1	1.4-V PCML	AP1	Transceiver receive channel
22	HSMA_RX_P2	1.4-V PCML	AM2	Transceiver receive channel
24	HSMA_RX_N2	1.4-V PCML	AM1	Transceiver receive channel
18	HSMA_RX_P3	1.4-V PCML	AK2	Transceiver receive channel
20	HSMA_RX_N3	1.4-V PCML	AK1	Transceiver receive channel
14	HSMA_RX_P4	1.4-V PCML	AH2	Transceiver receive channel
16	HSMA_RX_N4	1.4-V PCML	AH1	Transceiver receive channel
10	HSMA_RX_P5	1.4-V PCML	AF2	Transceiver receive channel
12	HSMA_RX_N5	1.4-V PCML	AF1	Transceiver receive channel
6	HSMA_RX_P6	1.4-V PCML	AD2	Transceiver receive channel
8	HSMA_RX_N6	1.4-V PCML	AD1	Transceiver receive channel
2	HSMA_RX_P7	1.4-V PCML	AB2	Transceiver receive channel
4	HSMA_RX_N7	1.4-V PCML	AB1	Transceiver receive channel
29	HSMA_TX_P0	1.4-V PCML	AU4	Transceiver transmit channel
31	HSMA_TX_N0	1.4-V PCML	AU3	Transceiver transmit channel
25	HSMA_TX_P1	1.4-V PCML	AN4	Transceiver transmit channel
27	HSMA_TX_N1	1.4-V PCML	AN3	Transceiver transmit channel
21	HSMA_TX_P2	1.4-V PCML	AL4	Transceiver transmit channel
23	HSMA_TX_N2	1.4-V PCML	AL3	Transceiver transmit channel
17	HSMA_TX_P3	1.4-V PCML	AJ4	Transceiver transmit channel
19	HSMA_TX_N3	1.4-V PCML	AJ3	Transceiver transmit channel
13	HSMA_TX_P4	1.4-V PCML	AG4	Transceiver transmit channel
15	HSMA_TX_N4	1.4-V PCML	AG3	Transceiver transmit channel
9	HSMA_TX_P5	1.4-V PCML	AE4	Transceiver transmit channel
11	HSMA_TX_N5	1.4-V PCML	AE3	Transceiver transmit channel
5	HSMA_TX_P6	1.4-V PCML	AC4	Transceiver transmit channel
7	HSMA_TX_N6	1.4-V PCML	AC3	Transceiver transmit channel
1	HSMA_TX_P7	1.4-V PCML	AA4	Transceiver transmit channel
3	HSMA_TX_N7	1.4-V PCML	AA3	Transceiver transmit channel
41	HSMA_D0	2.5-V	AJ29	Dedicated CMOS I/O bit 0
42	HSMA_D1	2.5-V	AK29	Dedicated CMOS I/O bit 1
43	HSMA_D2	2.5-V	AR28	Dedicated CMOS I/O bit 2
44	HSMA_D3	2.5-V	AP28	Dedicated CMOS I/O bit 3
35	JTAG_TCK	2.5-V	—	JTAG clock
38	JTAG_FPGA_TDO_RETIMER	2.5-V	—	JTAG data input
37	HSMA_JTAG_TDO	2.5-V	—	JTAG data output
36	HSMA_JTAG_TMS	2.5-V	—	JTAG mode select

Table 2-40. HSMC Port A Pin Assignments, Schematic Signal Names, and Functions (Part 3 of 4)

Board Reference (J1)	Schematic Signal Name	I/O Standard	Stratix V GX FPGA Device Pin Number	Description
160	HSMA_PRSN_Tn	2.5-V	AW8	Presence detect signal
34	HSMA_SCL	2.5-V	AM29	Management serial clock line
33	HSMA_SDA	2.5-V	AL29	Management serial data line
50	HSMA_RX_D_N0	LVDS or 2.5-V	AW11	Data bus
56	HSMA_RX_D_N1	LVDS or 2.5-V	AU12	Data bus
62	HSMA_RX_D_N2	LVDS or 2.5-V	AR12	Data bus
68	HSMA_RX_D_N3	LVDS or 2.5-V	AK12	Data bus
74	HSMA_RX_D_N4	LVDS or 2.5-V	AJ12	Data bus
80	HSMA_RX_D_N5	LVDS or 2.5-V	AG10	Data bus
86	HSMA_RX_D_N6	LVDS or 2.5-V	AE12	Data bus
92	HSMA_RX_D_N7	LVDS or 2.5-V	AC10	Data bus
104	HSMA_RX_D_N8	LVDS or 2.5-V	R9	Data bus
110	HSMA_RX_D_N9	LVDS or 2.5-V	L9	Data bus
116	HSMA_RX_D_N10	LVDS or 2.5-V	L8	Data bus
122	HSMA_RX_D_N11	LVDS or 2.5-V	G11	Data bus
128	HSMA_RX_D_N12	LVDS or 2.5-V	F9	Data bus
134	HSMA_RX_D_N13	LVDS or 2.5-V	E8	Data bus
140	HSMA_RX_D_N14	LVDS or 2.5-V	E11	Data bus
146	HSMA_RX_D_N15	LVDS or 2.5-V	C9	Data bus
152	HSMA_RX_D_N16	LVDS or 2.5-V	A10	Data bus
48	HSMA_RX_D_P0	LVDS or 2.5-V	AV11	Data bus
54	HSMA_RX_D_P1	LVDS or 2.5-V	AT12	Data bus
60	HSMA_RX_D_P2	LVDS or 2.5-V	AR11	Data bus
66	HSMA_RX_D_P3	LVDS or 2.5-V	AL12	Data bus
72	HSMA_RX_D_P4	LVDS or 2.5-V	AH12	Data bus
78	HSMA_RX_D_P5	LVDS or 2.5-V	AF10	Data bus
84	HSMA_RX_D_P6	LVDS or 2.5-V	AD12	Data bus
90	HSMA_RX_D_P7	LVDS or 2.5-V	AB10	Data bus
102	HSMA_RX_D_P8	LVDS or 2.5-V	T9	Data bus
108	HSMA_RX_D_P9	LVDS or 2.5-V	M9	Data bus
114	HSMA_RX_D_P10	LVDS or 2.5-V	M8	Data bus
120	HSMA_RX_D_P11	LVDS or 2.5-V	H11	Data bus
126	HSMA_RX_D_P12	LVDS or 2.5-V	G10	Data bus
132	HSMA_RX_D_P13	LVDS or 2.5-V	F8	Data bus
138	HSMA_RX_D_P14	LVDS or 2.5-V	F11	Data bus
144	HSMA_RX_D_P15	LVDS or 2.5-V	C8	Data bus
150	HSMA_RX_D_P16	LVDS or 2.5-V	B10	Data bus
49	HSMA_TX_D_N0	LVDS or 2.5-V	AU11	Data bus

Table 2-40. HSMC Port A Pin Assignments, Schematic Signal Names, and Functions (Part 4 of 4)

Board Reference (J1)	Schematic Signal Name	I/O Standard	Stratix V GX FPGA Device Pin Number	Description
55	HSMA_TX_D_N1	LVDS or 2.5-V	AN11	Data bus
61	HSMA_TX_D_N2	LVDS or 2.5-V	AL11	Data bus
67	HSMA_TX_D_N3	LVDS or 2.5-V	AF11	Data bus
73	HSMA_TX_D_N4	LVDS or 2.5-V	AE11	Data bus
79	HSMA_TX_D_N5	LVDS or 2.5-V	AE9	Data bus
85	HSMA_TX_D_N6	LVDS or 2.5-V	AC9	Data bus
91	HSMA_TX_D_N7	LVDS or 2.5-V	AC12	Data bus
103	HSMA_TX_D_N8	LVDS or 2.5-V	P8	Data bus
109	HSMA_TX_D_N9	LVDS or 2.5-V	N10	Data bus
115	HSMA_TX_D_N10	LVDS or 2.5-V	N9	Data bus
121	HSMA_TX_D_N11	LVDS or 2.5-V	J9	Data bus
127	HSMA_TX_D_N12	LVDS or 2.5-V	H10	Data bus
133	HSMA_TX_D_N13	LVDS or 2.5-V	D9	Data bus
139	HSMA_TX_D_N14	LVDS or 2.5-V	C10	Data bus
145	HSMA_TX_D_N15	LVDS or 2.5-V	A11	Data bus
151	HSMA_TX_D_N16	LVDS or 2.5-V	B8	Data bus
47	HSMA_TX_D_P0	LVDS or 2.5-V	AT11	Data bus
53	HSMA_TX_D_P1	LVDS or 2.5-V	AM11	Data bus
59	HSMA_TX_D_P2	LVDS or 2.5-V	AK11	Data bus
65	HSMA_TX_D_P3	LVDS or 2.5-V	AG12	Data bus
71	HSMA_TX_D_P4	LVDS or 2.5-V	AE10	Data bus
77	HSMA_TX_D_P5	LVDS or 2.5-V	AD9	Data bus
83	HSMA_TX_D_P6	LVDS or 2.5-V	AB9	Data bus
89	HSMA_TX_D_P7	LVDS or 2.5-V	AB12	Data bus
101	HSMA_TX_D_P8	LVDS or 2.5-V	R8	Data bus
107	HSMA_TX_D_P9	LVDS or 2.5-V	P10	Data bus
113	HSMA_TX_D_P10	LVDS or 2.5-V	N8	Data bus
119	HSMA_TX_D_P11	LVDS or 2.5-V	K9	Data bus
125	HSMA_TX_D_P12	LVDS or 2.5-V	J10	Data bus
131	HSMA_TX_D_P13	LVDS or 2.5-V	E9	Data bus
137	HSMA_TX_D_P14	LVDS or 2.5-V	D10	Data bus
143	HSMA_TX_D_P15	LVDS or 2.5-V	B11	Data bus
149	HSMA_TX_D_P16	LVDS or 2.5-V	A8	Data bus

Table 2-41 lists the HSMC port B interface pin assignments, signal names, and functions.

Table 2-41. HSMC Port B Pin Assignments, Schematic Signal Names, and Functions (Part 1 of 3)

Board Reference (J2)	Schematic Signal Name	I/O Standard	Stratix V GX FPGA Device Pin Number	Description
30	HSMB_RX_P0	1.4-V PCML	F2	Transceiver receive channel
32	HSMB_RX_N0	1.4-V PCML	F1	Transceiver receive channel
26	HSMB_RX_P1	1.4-V PCML	D2	Transceiver receive channel
28	HSMB_RX_N1	1.4-V PCML	D1	Transceiver receive channel
22	HSMB_RX_P2	1.4-V PCML	Y2	Transceiver receive channel
24	HSMB_RX_N2	1.4-V PCML	Y1	Transceiver receive channel
18	HSMB_RX_P3	1.4-V PCML	V2	Transceiver receive channel
20	HSMB_RX_N3	1.4-V PCML	V1	Transceiver receive channel
29	HSMB_TX_P0	1.4-V PCML	E4	Transceiver transmit channel
31	HSMB_TX_N0	1.4-V PCML	E3	Transceiver transmit channel
25	HSMB_TX_P1	1.4-V PCML	C4	Transceiver transmit channel
27	HSMB_TX_N1	1.4-V PCML	C3	Transceiver transmit channel
21	HSMB_TX_P2	1.4-V PCML	W4	Transceiver transmit channel
23	HSMB_TX_N2	1.4-V PCML	W3	Transceiver transmit channel
17	HSMB_TX_P3	1.4-V PCML	U4	Transceiver transmit channel
19	HSMB_TX_N3	1.4-V PCML	U3	Transceiver transmit channel
158	HSMB_CLK_IN_N2	LVDS or 2.5-V	N16	LVDS or CMOS clock in 2
96	HSMB_CLK_IN_P1	LVDS or 2.5-V	U15	Secondary differential clock in
156	HSMB_CLK_IN_P2	LVDS or 2.5-V	P16	Primary source-synchronous clock in
39	HSMB_CLK_OUT0	LVDS or 2.5-V	L16	Primary single-ended clock out
97	HSMB_CLK_OUT_N1	LVDS or 2.5-V	C16	LVDS or CMOS clock out 1
157	HSMB_CLK_OUT_N2	LVDS or 2.5-V	A16	LVDS or CMOS clock out 2
95	HSMB_CLK_OUT_P1	LVDS or 2.5-V	D16	Secondary differential clock out
155	HSMB_CLK_OUT_P2	LVDS or 2.5-V	B16	Primary source-synchronous clock out
50	HSMB_A0	2.5-V CMOS	N17	Memory address bit
54	HSMB_A1	2.5-V CMOS	P17	Memory address bit
56	HSMB_A2	2.5-V CMOS	H13	Memory address bit
60	HSMB_A3	2.5-V CMOS	G14	Memory address bit
62	HSMB_A4	2.5-V CMOS	L18	Memory address bit
74	HSMB_A5	2.5-V CMOS	L19	Memory address bit
78	HSMB_A6	2.5-V CMOS	K19	Memory address bit
80	HSMB_A7	2.5-V CMOS	J18	Memory address bit
84	HSMB_A8	2.5-V CMOS	A17	Memory address bit
86	HSMB_A9	2.5-V CMOS	B17	Memory address bit
104	HSMB_A10	2.5-V CMOS	G18	Memory address bit
108	HSMB_A11	2.5-V CMOS	C18	Memory address bit

Table 2-41. HSMC Port B Pin Assignments, Schematic Signal Names, and Functions (Part 2 of 3)

Board Reference (J2)	Schematic Signal Name	I/O Standard	Stratix V GX FPGA Device Pin Number	Description
110	HSMB_A12	2.5-V CMOS	D18	Memory address bit
114	HSMB_A13	2.5-V CMOS	A19	Memory address bit
116	HSMB_A14	2.5-V CMOS	B19	Memory address bit
128	HSMB_A15	2.5-V CMOS	C19	Memory address bit
43	HSMB_ADDR_CMD0	2.5-V CMOS	M18	Memory address or command
132	HSMB_BA0	2.5-V CMOS	E18	Memory bank address bit
134	HSMB_BA1	2.5-V CMOS	D19	Memory bank address bit
138	HSMB_BA2	2.5-V CMOS	F18	Memory bank address bit
140	HSMB_BA3	2.5-V CMOS	E19	Memory bank address bit
151	HSMB_C_N	2.5-V CMOS	M15	ODT
149	HSMB_C_P	2.5-V CMOS	N15	QVLD
44	HSMB_CASN	2.5-V CMOS	R16	Memory address or command
150	HSMB_CKE	2.5-V CMOS	G19	Memory address or command
40	HSMB_CLK_IN0	LVDS or 2.5-V	AF29	Primary single-ended clock in
98	HSMB_CLK_IN_N1	LVDS or 2.5-V	T16	LVDS or CMOS clock in 1
152	HSMB_CSN	2.5-V CMOS	H19	Memory address or command
48	HSMB_DM0	2.5-V CMOS	U11	Data mask
72	HSMB_DM1	2.5-V CMOS	J13	Data mask
102	HSMB_DM2	2.5-V CMOS	U12	Data mask
126	HSMB_DM3	2.5-V CMOS	H14	Data mask
47	HSMB_DQ0	2.5-V CMOS	T12	Memory data bus
49	HSMB_DQ1	2.5-V CMOS	R12	Memory data bus
53	HSMB_DQ2	2.5-V CMOS	N12	Memory data bus
55	HSMB_DQ3	2.5-V CMOS	N13	Memory data bus
59	HSMB_DQ4	2.5-V CMOS	M12	Memory data bus
61	HSMB_DQ5	2.5-V CMOS	L12	Memory data bus
65	HSMB_DQ6	2.5-V CMOS	K12	Memory data bus
67	HSMB_DQ7	2.5-V CMOS	J12	Memory data bus
71	HSMB_DQ8	2.5-V CMOS	G12	Memory data bus
73	HSMB_DQ9	2.5-V CMOS	G13	Memory data bus
77	HSMB_DQ10	2.5-V CMOS	F12	Memory data bus
79	HSMB_DQ11	2.5-V CMOS	E12	Memory data bus
83	HSMB_DQ12	2.5-V CMOS	D12	Memory data bus
85	HSMB_DQ13	2.5-V CMOS	C12	Memory data bus
89	HSMB_DQ14	2.5-V CMOS	B13	Memory data bus
91	HSMB_DQ15	2.5-V CMOS	A13	Memory data bus
101	HSMB_DQ16	2.5-V CMOS	U13	Memory data bus
103	HSMB_DQ17	2.5-V CMOS	T13	Memory data bus

Table 2-41. HSMC Port B Pin Assignments, Schematic Signal Names, and Functions (Part 3 of 3)

Board Reference (J2)	Schematic Signal Name	I/O Standard	Stratix V GX FPGA Device Pin Number	Description
107	HSMB_DQ18	2.5-V CMOS	N14	Memory data bus
109	HSMB_DQ19	2.5-V CMOS	M14	Memory data bus
113	HSMB_DQ20	2.5-V CMOS	U14	Memory data bus
115	HSMB_DQ21	2.5-V CMOS	L15	Memory data bus
119	HSMB_DQ22	2.5-V CMOS	J14	Memory data bus
121	HSMB_DQ23	2.5-V CMOS	J15	Memory data bus
125	HSMB_DQ24	2.5-V CMOS	G15	Memory data bus
127	HSMB_DQ25	2.5-V CMOS	F14	Memory data bus
131	HSMB_DQ26	2.5-V CMOS	F15	Memory data bus
133	HSMB_DQ27	2.5-V CMOS	E14	Memory data bus
137	HSMB_DQ28	2.5-V CMOS	B14	Memory data bus
139	HSMB_DQ29	2.5-V CMOS	A14	Memory data bus
143	HSMB_DQ30	2.5-V CMOS	C14	Memory data bus
145	HSMB_DQ31	2.5-V CMOS	C15	Memory data bus
68	HSMB_DQS_N0	2.5-V CMOS	K13	Memory data strobe (negative)
92	HSMB_DQS_N1	2.5-V CMOS	C13	Memory data strobe (negative)
122	HSMB_DQS_N2	2.5-V CMOS	P14	Memory data strobe (negative)
146	HSMB_DQS_N3	2.5-V CMOS	D15	Memory data strobe (negative)
66	HSMB_DQS_P0	2.5-V CMOS	L13	Memory data strobe (positive)
90	HSMB_DQS_P1	2.5-V CMOS	D13	Memory data strobe (positive)
120	HSMB_DQS_P2	2.5-V CMOS	R14	Memory data strobe (positive)
144	HSMB_DQS_P3	2.5-V CMOS	E15	Memory data strobe (positive)
35	JTAG_TCK	2.5-V	AA31	JTAG clock
38	HSMB_JTAG_TDI	2.5-V	—	JTAG data input
37	HSMB_JTAG_TDO	2.5-V	—	JTAG data output
36	HSMB_JTAG_TMS	2.5-V	—	JTAG mode select
160	HSMB_PRSNTN	2.5-V	AU7	Presence detect signal
42	HSMB_RASN	2.5-V CMOS	P13	Memory address or command
34	HSMB_SCL	2.5-V CMOS	AL30	Management serial clock line
33	HSMB_SDA	2.5-V CMOS	AK30	Management serial data line
41	HSMB_WEN	1.4-V PCML	M17	Memory address or command

Table 2-42 lists the HSMC connector component reference and manufacturing information.

Table 2-42. HSMC Connector Component Reference and Manufacturing Information

Board Reference	Description	Manufacturer	Manufacturing Part Number	Manufacturer Website
J1 and J2	HSMC, custom version of QSH-DP family high-speed socket.	Samtec	ASP-122953-01	www.samtec.com

SDI Video Output/Input

The serial digital interface (SDI) video port consists of a LMH0303 cable driver and a LMH0384 receiver cable equalizer. The PHY devices from National Semiconductor interface to single-ended 75-Ω SMB connectors.

The cable driver supports operation at 270 Mbit standard definition (SD), 1.5 Gbit high definition (HD), and 3.0 Gbit dual-link HD modes. Control signals are allowed for SD and HD modes selections, as well as device enable. The device can be clocked by the 148.5 MHz voltage-controlled crystal oscillator (VCXO) and matched to incoming signals within 50 ppm using the UP and DN voltage control lines to the VCXO.

Table 2-43 shows the supported output standards for the SD and HD input.

Table 2-43. Supported Output Standards for SD and HD Input

SD_HD Input	Supported Output Standards	Rise Time
0	SMPTE 424M, SMPTE 292M	Faster
1	SMPTE 259M	Slower



For more information about the application circuit of the LMH0303 cable driver, refer to the cable driver data sheet at www.national.com.

Table 2-44 summarizes the SDI video output interface pin assignments, signal names, and functions.

Table 2-44. SDI Video Output Interface Pin Assignments, Schematic Signal Names, and Functions

Board Reference (U25)	Schematic Signal Name	I/O Standard	Stratix V GX FPGA Device Pin Number	Description
6	SDI_TX_EN	2.5-V	AK27	Device enable
4	SDI_TX_RSET	3.3-V	—	Device reset
10	SDI_TX_SD_HDn	2.5-V	AJ27	High definition select
1	SDI_TX_P	1.4-V PCML	E36	SDI video input P
2	SDI_TX_N	1.4-V PCML	E37	SDI video input N

The cable equalizer supports operation at 270 Mbit SD, 1.5 Gbit HD, and 3.0 Gbit dual-link HD modes. Control signals are allowed for bypassing or disabling the device, as well as a carrier detect or auto-mute signal interface.

Table 2-45 shows the cable equalizer lengths.

Table 2-45. SDI Cable Equalizer Lengths

Data Rate (Mbps)	Cable Type	Maximum Cable Length (m)
270	Belden 1694A	400
1485		140
2970		120

Figure 2-9 is an excerpt from the LMH0384 cable equalizer data sheet which shows the SDI cable equalizer.

Figure 2-9. SDI Cable Equalizer

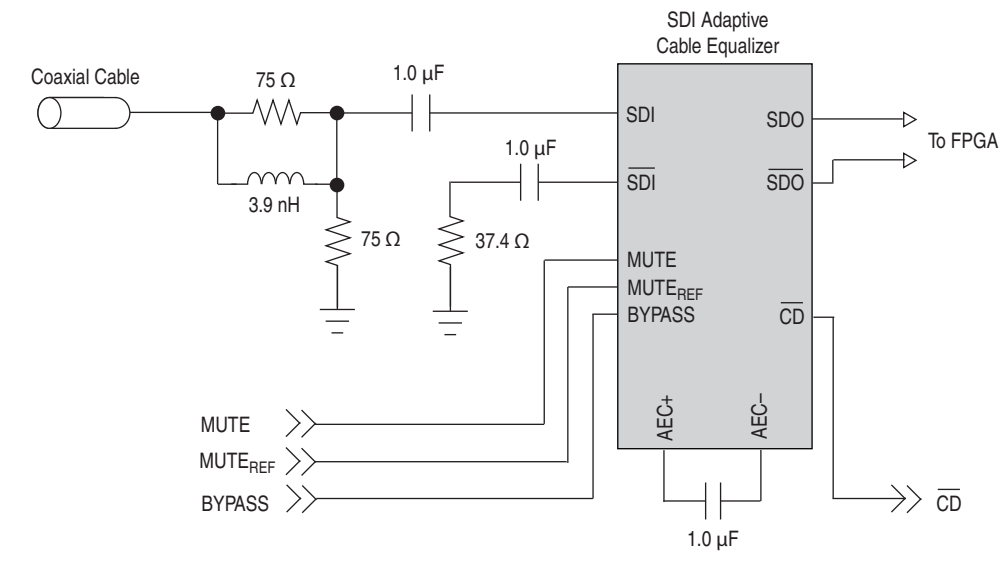

Table 2-46 summarizes the SDI video input interface pin assignments, signal names, and functions.

Table 2-46. SDI Video Input Interface Pin Assignments, Schematic Signal Names, and Functions

Board Reference (U24)	Schematic Signal Name	I/O Standard	Stratix V GX FPGA Device Pin Number	Description
7	SDI_RX_BYPASS	2.5-V	AB30	Equalizer bypass enable
14	SDI_RX_EN	2.5-V	AB28	Device enable
11	SDI_RX_P	1.4-V PCML	F38	SDI video output P
10	SDI_RX_N	1.4-V PCML	F39	SDI video output N

Table 2-47 lists the SDI connector component reference and manufacturing information.

Table 2-47. HSMC Connector Component Reference and Manufacturing Information

Board Reference	Description	Manufacturer	Manufacturing Part Number	Manufacturer Website
U25	3-Gbps HD/SD SDI cable driver	National Semiconductor	LMH0303SQ	www.national.com
U24	3-Gbps HD/SD SDI adaptive cable equalizer	National Semiconductor	LMH0384SQ	www.national.com

40G QSFP Connector

The development board has a 40G QSFP connector that uses four transceiver channels from the Stratix V GX FPGA device. These modules takes in serial data from the Stratix V GX FPGA device and transform them to optical signals. The board includes a cage assembly for the QSFP connector.

Table 2-48 summarizes the QSFP connector pin assignments, signal names, and functions.

Table 2-48. 40G QSFP Pin Assignments, Schematic Signal Names, and Functions (Part 1 of 2)

Board Reference (J12)	Schematic Signal Name	I/O Standard	Stratix V GX FPGA Device Pin Number	Description
17	QSFP_RX_P0	CML	P38	QSFP receiver data
18	QSFP_RX_N0	CML	P39	QSFP receiver data
22	QSFP_RX_P1	CML	M38	QSFP receiver data
21	QSFP_RX_N1	CML	M39	QSFP receiver data
14	QSFP_RX_P2	CML	K38	QSFP receiver data
15	QSFP_RX_N2	CML	K39	QSFP receiver data
25	QSFP_RX_P3	CML	H38	QSFP receiver data
24	QSFP_RX_N3	CML	H39	QSFP receiver data
36	QSFP_TX_P0	CML	N36	QSFP transmitter data
37	QSFP_TX_N0	CML	N37	QSFP transmitter data
3	QSFP_TX_P1	CML	L36	QSFP transmitter data
2	QSFP_TX_N1	CML	L37	QSFP transmitter data
33	QSFP_TX_P2	CML	J36	QSFP transmitter data
34	QSFP_TX_N2	CML	J37	QSFP transmitter data
6	QSFP_TX_P3	CML	G36	QSFP transmitter data
5	QSFP_TX_N3	CML	G37	QSFP transmitter data
28	QSFP_INTERRUPTn	3.3-V LVTTTL	AE27	QSFP interrupt
31	QSFP_LP_MODE	3.3-V LVTTTL	AD27	QSFP low power mode
27	QSFP_MOD_PRSn	3.3-V LVTTTL	AH27	Module present
8	QSFP_MOD_SELn	3.3-V LVTTTL	AG27	Module select
9	QSFP_RSTn	3.3-V LVTTTL	AE30	Module reset

Table 2–48. 40G QSFP Pin Assignments, Schematic Signal Names, and Functions (Part 2 of 2)

Board Reference (J12)	Schematic Signal Name	I/O Standard	Stratix V GX FPGA Device Pin Number	Description
11	QSFP_SCL	3.3-V LVTTTL	AD30	QSFP serial 2-wire clock
12	QSFP_SDA	3.3-V LVTTTL	AC30	QSFP serial 2-wire data

Table 2–49 lists the QSFP interface component reference and manufacturing information.

Table 2–49. QSFP Interface Component Reference and Manufacturing Information

Board Reference	Description	Manufacturer	Manufacturing Part Number	Manufacturer Website
J12	QSFP cage	Tyco Electronics	1888617-1	www.te.com
	QSFP connector	Tyco Electronics	1761987-9	www.te.com

Memory

This section describes the board’s memory interface support, signal names, types, and connectivity relative to the Stratix V GX FPGA device. The board has the following memory interfaces:

- DDR3
- QDRII+
- Flash



For more information about the memory interfaces, refer to the [External Memory Interface Handbook](#) page of the Altera website..

DDR3

The development board supports a 16Mx72x8 bank DDR3 SDRAM interface for very high-speed sequential memory access. The 72-bit data bus comprises of four x16 devices and one x8 device with a single address or command bus. This interface connects to the vertical I/O banks on the top edge of the FPGA.

The DDR3 devices shipped with this board are running at 533 MHz, for a total theoretical bandwidth of over 76.75 Gbps. These devices run at a minimum frequency of 303 MHz.



The DDR3 interface on the development board supports a maximum frequency of 800 MHz.

Table 2-50 lists the DDR3 x16 devices pin assignments, signal names, and functions.

Table 2-50. DDR3 x16 Devices Pin Assignments, Schematic Signal Names, and Functions (Part 1 of 4)

Board Reference (U12, U17, U21, U23, U28)	Schematic Signal Name	I/O Standard	Stratix V GX FPGA Device Pin Number	Description
DDR3 x16 / DDR3 x8 pins				
T3	DDR3_A13	1.5-V SSTL Class I	J31	Address bus
N7	DDR3_A12	1.5-V SSTL Class I	R30	Address bus
R7	DDR3_A11	1.5-V SSTL Class I	L31	Address bus
L7	DDR3_A10	1.5-V SSTL Class I	J30	Address bus
R3	DDR3_A9	1.5-V SSTL Class I	J29	Address bus
T8	DDR3_A8	1.5-V SSTL Class I	P31	Address bus
R2	DDR3_A7	1.5-V SSTL Class I	F30	Address bus
R8	DDR3_A6	1.5-V SSTL Class I	N31	Address bus
P2	DDR3_A5	1.5-V SSTL Class I	E31	Address bus
P8	DDR3_A4	1.5-V SSTL Class I	L30	Address bus
N2	DDR3_A3	1.5-V SSTL Class I	D31	Address bus
P3	DDR3_A2	1.5-V SSTL Class I	H31	Address bus
P7	DDR3_A1	1.5-V SSTL Class I	K31	Address bus
N3	DDR3_A0	1.5-V SSTL Class I	G31	Address bus
M3	DDR3_BA2	1.5-V SSTL Class I	E30	Bank address bus
N8	DDR3_BA1	1.5-V SSTL Class I	K30	Bank address bus
M2	DDR3_BA0	1.5-V SSTL Class I	C31	Bank address bus
J3	DDR3_RASn	1.5-V SSTL Class I	B26	Row address select
K3	DDR3_CASn	1.5-V SSTL Class I	B28	Column address select
L2	DDR3_CSn	1.5-V SSTL Class I	B31	Chip select
L3	DDR3_WEn	1.5-V SSTL Class I	C30	Write enable
K1	DDR3_ODT	1.5-V SSTL Class I	A31	On-die termination enable
L8	DDR3_ZQ	1.5-V SSTL Class I	—	ZQ impedance calibration
K9	DDR3_CKE	1.5-V SSTL Class I	R31	Clock enable
J7	DDR3_CLK_P	1.5-V SSTL Class I	N30	Differential output clock
K7	DDR3_CLK_N	1.5-V SSTL Class I	M30	Differential output clock
DDR3 x16 pins				
U28.E3	DDR3_DQ0	1.5-V SSTL Class I	A28	Data bus byte lane 0
U28.F7	DDR3_DQ1	1.5-V SSTL Class I	E28	Data bus byte lane 0
U28.F2	DDR3_DQ2	1.5-V SSTL Class I	B29	Data bus byte lane 0
U28.F8	DDR3_DQ3	1.5-V SSTL Class I	F29	Data bus byte lane 0
U28.H3	DDR3_DQ4	1.5-V SSTL Class I	D28	Data bus byte lane 0
U28.H8	DDR3_DQ5	1.5-V SSTL Class I	H28	Data bus byte lane 0
U28.G2	DDR3_DQ6	1.5-V SSTL Class I	C28	Data bus byte lane 0
U28.H7	DDR3_DQ7	1.5-V SSTL Class I	G28	Data bus byte lane 0

Table 2-50. DDR3 x16 Devices Pin Assignments, Schematic Signal Names, and Functions (Part 2 of 4)

Board Reference (U12, U17, U21, U23, U28)	Schematic Signal Name	I/O Standard	Stratix V GX FPGA Device Pin Number	Description
U28.E7	DDR3_DM0	1.5-V SSTL Class I	A29	Write mask byte lane 0
U28.F3	DDR3_DQS_P0	1.5-V SSTL Class I	H29	Data strobe P byte lane 0
U28.G3	DDR3_DQS_N0	1.5-V SSTL Class I	G29	Data strobe N byte lane 0
U28.D7	DDR3_DQ8	1.5-V SSTL Class I	K28	Data bus byte lane 1
U28.C3	DDR3_DQ9	1.5-V SSTL Class I	M29	Data bus byte lane 1
U28.C8	DDR3_DQ10	1.5-V SSTL Class I	L28	Data bus byte lane 1
U28.C2	DDR3_DQ11	1.5-V SSTL Class I	R29	Data bus byte lane 1
U28.A7	DDR3_DQ12	1.5-V SSTL Class I	P29	Data bus byte lane 1
U28.A2	DDR3_DQ13	1.5-V SSTL Class I	V29	Data bus byte lane 1
U28.B8	DDR3_DQ14	1.5-V SSTL Class I	N28	Data bus byte lane 1
U28.A3	DDR3_DQ15	1.5-V SSTL Class I	U29	Data bus byte lane 1
U28.D3	DDR3_DM1	1.5-V SSTL Class I	J28	Write mask byte lane 1
U28.C7	DDR3_DQS_P1	1.5-V SSTL Class I	U30	Data strobe P byte lane 1
U28.B7	DDR3DQS_N1	1.5-V SSTL Class I	T30	Data strobe N byte lane 1
U23.E3	DDR3_DQ16	1.5-V SSTL Class I	G26	Data bus byte lane 2
U23.F7	DDR3_DQ17	1.5-V SSTL Class I	D27	Data bus byte lane 2
U23.F2	DDR3_DQ18	1.5-V SSTL Class I	F26	Data bus byte lane 2
U23.F8	DDR3_DQ19	1.5-V SSTL Class I	C27	Data bus byte lane 2
U23.H3	DDR3_DQ20	1.5-V SSTL Class I	C26	Data bus byte lane 2
U23.H8	DDR3_DQ21	1.5-V SSTL Class I	J26	Data bus byte lane 2
U23.G2	DDR3_DQ22	1.5-V SSTL Class I	E27	Data bus byte lane 2
U23.H7	DDR3_DQ23	1.5-V SSTL Class I	H26	Data bus byte lane 2
U23.E7	DDR3_DM2	1.5-V SSTL Class I	A26	Write mask byte lane 2
U23.F3	DDR3_DQS_P2	1.5-V SSTL Class I	G27	Data strobe P byte lane 2
U28.G3	DDR3_DQS_N2	1.5-V SSTL Class I	F27	Data strobe N byte lane 2
U23.D7	DDR3_DQ24	1.5-V SSTL Class I	J27	Data bus byte lane 3
U23.C3	DDR3_DQ25	1.5-V SSTL Class I	N27	Data bus byte lane 3
U23.C8	DDR3_DQ26	1.5-V SSTL Class I	T27	Data bus byte lane 3
U23.C2	DDR3_DQ27	1.5-V SSTL Class I	M27	Data bus byte lane 3
U23.A7	DDR3_DQ28	1.5-V SSTL Class I	U26	Data bus byte lane 3
U23.A2	DDR3_DQ29	1.5-V SSTL Class I	P28	Data bus byte lane 3
U23.B8	DDR3_DQ30	1.5-V SSTL Class I	U27	Data bus byte lane 3
U23.A3	DDR3_DQ31	1.5-V SSTL Class I	R27	Data bus byte lane 3
U23.D3	DDR3_DM3	1.5-V SSTL Class I	L27	Write mask byte lane 3
U23.C7	DDR3_DQS_P3	1.5-V SSTL Class I	U28	Data strobe P byte lane 3
U23.B7	DDR3_DQS_N3	1.5-V SSTL Class I	T28	Data strobe N byte lane 3
U21.E3	DDR3_DQ32	1.5-V SSTL Class I	B25	Data bus byte lane 4
U21.F7	DDR3_DQ33	1.5-V SSTL Class I	F24	Data bus byte lane 4

Table 2-50. DDR3 x16 Devices Pin Assignments, Schematic Signal Names, and Functions (Part 3 of 4)

Board Reference (U12, U17, U21, U23, U28)	Schematic Signal Name	I/O Standard	Stratix V GX FPGA Device Pin Number	Description
U21.F2	DDR3_DQ34	1.5-V SSTL Class I	C25	Data bus byte lane 4
U21.F8	DDR3_DQ35	1.5-V SSTL Class I	G24	Data bus byte lane 4
U21.H3	DDR3_DQ36	1.5-V SSTL Class I	D24	Data bus byte lane 4
U21.H8	DDR3_DQ37	1.5-V SSTL Class I	H25	Data bus byte lane 4
U21.G2	DDR3_DQ38	1.5-V SSTL Class I	C24	Data bus byte lane 4
U21.H7	DDR3_DQ39	1.5-V SSTL Class I	G25	Data bus byte lane 4
U21.E7	DDR3_DM4	1.5-V SSTL Class I	A25	Write mask byte lane 4
U21.F3	DDR3DQS_P4	1.5-V SSTL Class I	E24	Data strobe P byte lane 4
U21.G3	DDR3_DQS_N4	1.5-V SSTL Class I	E25	Data strobe N byte lane 4
U21.D7	DDR3_DQ40	1.5-V SSTL Class I	J25	Data bus byte lane 5
U21.C3	DDR3_DQ41	1.5-V SSTL Class I	N26	Data bus byte lane 5
U21.C8	DDR3_DQ42	1.5-V SSTL Class I	L26	Data bus byte lane 5
U21.C2	DDR3_DQ43	1.5-V SSTL Class I	P26	Data bus byte lane 5
U21.A7	DDR3_DQ44	1.5-V SSTL Class I	P25	Data bus byte lane 5
U21.A2	DDR3_DQ45	1.5-V SSTL Class I	T25	Data bus byte lane 5
U21.B8	DDR3_DQ46	1.5-V SSTL Class I	N25	Data bus byte lane 5
U21.A3	DDR3_DQ47	1.5-V SSTL Class I	U25	Data bus byte lane 5
U21.D3	DDR3_DM5	1.5-V SSTL Class I	K25	Write mask byte lane 5
U21.C7	DDR3_DQS_P5	1.5-V SSTL Class I	R25	Data strobe P byte lane 5
U21.B7	DDR3_DQS_N5	1.5-V SSTL Class I	R26	Data strobe N byte lane 5
U17.E3	DDR3_DQ48	1.5-V SSTL Class I	H22	Data bus byte lane 6
U17.F7	DDR3_DQ49	1.5-V SSTL Class I	B23	Data bus byte lane 6
U17.F2	DDR3_DQ50	1.5-V SSTL Class I	G22	Data bus byte lane 6
U17.F8	DDR3_DQ51	1.5-V SSTL Class I	G23	Data bus byte lane 6
U17.H3	DDR3_DQ52	1.5-V SSTL Class I	D22	Data bus byte lane 6
U17.H8	DDR3_DQ53	1.5-V SSTL Class I	H23	Data bus byte lane 6
U17.G2	DDR3_DQ54	1.5-V SSTL Class I	C22	Data bus byte lane 6
U17.H7	DDR3_DQ55	1.5-V SSTL Class I	A23	Data bus byte lane 6
U17.E7	DDR3_DM6	1.5-V SSTL Class I	A22	Write mask byte lane 6
U17.F3	DDR3_DQS_P6	1.5-V SSTL Class I	F23	Data strobe P byte lane 6
U17.G3	DDR3_DQS_N6	1.5-V SSTL Class I	E23	Data strobe N byte lane 6
U17.D7	DDR3_DQ56	1.5-V SSTL Class I	A20	Data bus byte lane 7
U17.C3	DDR3_DQ57	1.5-V SSTL Class I	C20	Data bus byte lane 7
U17.C8	DDR3_DQ58	1.5-V SSTL Class I	F20	Data bus byte lane 7
U17.C2	DDR3_DQ59	1.5-V SSTL Class I	C21	Data bus byte lane 7
U17.A7	DDR3_DQ60	1.5-V SSTL Class I	H20	Data bus byte lane 7
U17.A2	DDR3_DQ61	1.5-V SSTL Class I	D21	Data bus byte lane 7
U17.B8	DDR3_DQ62	1.5-V SSTL Class I	G20	Data bus byte lane 7

Table 2-50. DDR3 x16 Devices Pin Assignments, Schematic Signal Names, and Functions (Part 4 of 4)

Board Reference (U12, U17, U21, U23, U28)	Schematic Signal Name	I/O Standard	Stratix V GX FPGA Device Pin Number	Description
U17.A3	DDR3_DQ63	1.5-V SSTL Class I	E20	Data bus byte lane 7
U17.D3	DDR3_DM7	1.5-V SSTL Class I	B20	Write mask byte lane 7
U17.C7	DDR3_DQS_P7	1.5-V SSTL Class I	G21	Data strobe P byte lane 7
U17.B7	DDR3_DQS_N7	1.5-V SSTL Class I	F21	Data strobe N byte lane 7
DDR3 x8 pins				
U12.B3	DDR3_DQ64	1.5-V SSTL Class I	M20	Data bus byte lane 8
U12.C7	DDR3_DQ65	1.5-V SSTL Class I	L20	Data bus byte lane 8
U12.C2	DDR3_DQ66	1.5-V SSTL Class I	N22	Data bus byte lane 8
U12.C8	DDR3_DQ67	1.5-V SSTL Class I	J21	Data bus byte lane 8
U12.E3	DDR3_DQ68	1.5-V SSTL Class I	N21	Data bus byte lane 8
U12.E8	DDR3_DQ69	1.5-V SSTL Class I	K21	Data bus byte lane 8
U12.D2	DDR3_DQ70	1.5-V SSTL Class I	N20	Data bus byte lane 8
U12.E7	DDR3_DQ71	1.5-V SSTL Class I	L21	Data bus byte lane 8
U12.B7	DDR3_DM8	1.5-V SSTL Class I	M21	Write mask byte lane 8
U12.C3	DDR3_DQS_P8	1.5-V SSTL Class I	K22	Data strobe P byte lane 8
U12.D3	DDR3_DQS_N8	1.5-V SSTL Class I	J22	Data strobe N byte lane 8

Table 2-51 lists the DDR3 component reference and manufacturing information.

Table 2-51. DDR3 Component Reference and Manufacturing Information

Board Reference	Description	Manufacturer	Manufacturing Part Number	Manufacturer Website
U17, U21, U23, U28	16 M × 16-bit × 8 banks, 800 MHz, CL11	Micron	MT41J128M16HA-125	www.micron.com
U12	16 M × 8-bit × 8 banks, 800 MHz, CL11	Micron	MT41J128M8JP-125	www.micron.com

QDRII+

The development board supports a burst-of-4 QDRII+ SRAM memory device for very-high-speed, low-latency memory access. The QDRII+ has a x18 interface, providing addressing to a device of up to a 32 Mb.

The QDRII+ has separate read and write data ports with DDR signaling at up to 550 MHz. The pinout and footprint is compatible with a burst-of-2 QDRII SSRAM memory device. Although the FPGA supports up to 350 MHz QDRII data, the fastest RoHS compliant QDRII device being manufactured is only 333 MHz.

Table 2-52 lists the QDRII+ pin assignments, signal names, and functions.

Table 2-52. QDRII+ Pin Assignments, Signal Names and Functions (Part 1 of 2)

Board Reference (U5)	Schematic Signal Name	I/O Standard	Stratix V GX FPGA Device Pin Number	Description
A2	QDRII_A20	1.8-V HSTL Class I	AA13	Address bus (reserved for 144M)
A10	QDRII_A19	1.8-V HSTL Class I	AP12	Address bus (reserved for 72M)
A3	QDRII_A18	1.8-V HSTL Class I	AA12	Address bus
A9	QDRII_A17	1.8-V HSTL Class I	AN12	Address bus
R7	QDRII_A16	1.8-V HSTL Class I	AL13	Address bus
R5	QDRII_A15	1.8-V HSTL Class I	AF14	Address bus
R4	QDRII_A14	1.8-V HSTL Class I	AC13	Address bus
R3	QDRII_A13	1.8-V HSTL Class I	AB13	Address bus
P8	QDRII_A12	1.8-V HSTL Class I	AW14	Address bus
P7	QDRII_A11	1.8-V HSTL Class I	AM13	Address bus
P5	QDRII_A10	1.8-V HSTL Class I	AE14	Address bus
P4	QDRII_A9	1.8-V HSTL Class I	AC14	Address bus
N7	QDRII_A8	1.8-V HSTL Class I	AJ13	Address bus
N6	QDRII_A7	1.8-V HSTL Class I	AH13	Address bus
N5	QDRII_A6	1.8-V HSTL Class I	AD14	Address bus
C7	QDRII_A5	1.8-V HSTL Class I	AN13	Address bus
C5	QDRII_A4	1.8-V HSTL Class I	AG13	Address bus
B8	QDRII_A3	1.8-V HSTL Class I	AT14	Address bus
B4	QDRII_A2	1.8-V HSTL Class I	AF13	Address bus
R8	QDRII_A1	1.8-V HSTL Class I	AP13	Address bus
R9	QDRII_A0	1.8-V HSTL Class I	AU14	Address bus
N2	QDRII_D17	1.8-V HSTL Class I	AU15	Write data bus
M3	QDRII_D16	1.8-V HSTL Class I	AR15	Write data bus
L3	QDRII_D15	1.8-V HSTL Class I	AR14	Write data bus
J3	QDRII_D14	1.8-V HSTL Class I	AP15	Write data bus
G2	QDRII_D13	1.8-V HSTL Class I	AT15	Write data bus
F3	QDRII_D12	1.8-V HSTL Class I	AN14	Write data bus
D2	QDRII_D11	1.8-V HSTL Class I	AN15	Write data bus
C3	QDRII_D10	1.8-V HSTL Class I	AM14	Write data bus
B3	QDRII_D9	1.8-V HSTL Class I	AL15	Write data bus
C11	QDRII_D8	1.8-V HSTL Class I	AG14	Write data bus
D11	QDRII_D7	1.8-V HSTL Class I	AD16	Write data bus
E10	QDRII_D6	1.8-V HSTL Class I	AE15	Write data bus
G11	QDRII_D5	1.8-V HSTL Class I	AA14	Write data bus
J11	QDRII_D4	1.8-V HSTL Class I	AA15	Write data bus
K10	QDRII_D3	1.8-V HSTL Class I	AC15	Write data bus
M11	QDRII_D2	1.8-V HSTL Class I	AB15	Write data bus

Table 2-52. QDRII+ Pin Assignments, Signal Names and Functions (Part 2 of 2)

Board Reference (U5)	Schematic Signal Name	I/O Standard	Stratix V GX FPGA Device Pin Number	Description
N11	QDRII_D1	1.8-V HSTL Class I	AB16	Write data bus
P10	QDRII_D0	1.8-V HSTL Class I	AD15	Write data bus
B6	QDRII_K_P	1.8-V HSTL Class I	AK14	Write clock P
A6	QDRII_K_N	1.8-V HSTL Class I	AL14	Write clock N
A4	QDRII_WPSn	1.8-V HSTL Class I	AK15	Write port select
B7	QDRII_BWSn0	1.8-V HSTL Class I	AH15	Write byte write select 0
A5	QDRII_BWSn1	1.8-V HSTL Class I	AJ15	Write byte write select 1
P3	QDRII_Q17	1.8-V HSTL Class I	AM19	Read data bus
N3	QDRII_Q16	1.8-V HSTL Class I	AN18	Read data bus
L2	QDRII_Q15	1.8-V HSTL Class I	AP19	Read data bus
K3	QDRII_Q14	1.8-V HSTL Class I	AR18	Read data bus
G3	QDRII_Q13	1.8-V HSTL Class I	AP18	Read data bus
F2	QDRII_Q12	1.8-V HSTL Class I	AR19	Read data bus
E3	QDRII_Q11	1.8-V HSTL Class I	AL18	Read data bus
D3	QDRII_Q10	1.8-V HSTL Class I	AK18	Read data bus
B2	QDRII_Q9	1.8-V HSTL Class I	AJ19	Read data bus
B11	QDRII_Q8	1.8-V HSTL Class I	AH19	Read data bus
C10	QDRII_Q7	1.8-V HSTL Class I	AJ18	Read data bus
E11	QDRII_Q6	1.8-V HSTL Class I	AH18	Read data bus
F11	QDRII_Q5	1.8-V HSTL Class I	AG19	Read data bus
J10	QDRII_Q4	1.8-V HSTL Class I	AG18	Read data bus
K11	QDRII_Q3	1.8-V HSTL Class I	AE19	Read data bus
L11	QDRII_Q2	1.8-V HSTL Class I	AD18	Read data bus
M10	QDRII_Q1	1.8-V HSTL Class I	AE18	Read data bus
P11	QDRII_Q0	1.8-V HSTL Class I	AD17	Read data bus
P6	QDRII_C_P	1.8-V HSTL Class I	AT18	Clock P
R6	QDRII_C_N	1.8-V HSTL Class I	AU18	Clock N
A11	QDRII_CQ_P	1.8-V HSTL Class I	AN19	Echo clock P
A1	QDRII_CQ_N	1.8-V HSTL Class I	AF19	Echo clock N
A8	QDRII_RPSn	1.8-V HSTL Class I	AG15	Read port select
H1	QDRII_DOFFn	1.8-V HSTL Class I	AV13	DLL enable

Table 2-53 lists the QDRII+ component reference and manufacturing information.

Table 2-53. QDRII+ Component Reference and Manufacturing Information

Board Reference	Description	Manufacturer	Manufacturing Part Number	Manufacturer Website
U5	QDRII+, 2 M × 18, 550 MHz	Cypress	CY7C2263KV18-550BZXI	www.cypress.com

Flash

The development board has two 512-Mb CFI-compatible synchronous flash device for non-volatile storage of FPGA configuration data, board information, test application data, and user code space.

Each interface has a 16-bit data bus and the two devices combined allow for x32 FPP configuration. This device is part of the shared flash and MAX (FM) bus, which connects to the flash memory and MAX V CPLD System Controller.

Each 16-bit data memory interface can sustain burst read operations at up to 52 MHz for a throughput of 832 Mbps per device. The write performance is 270 μ s for a single word and 310 μ s for a 32-word buffer. The erase time is 800 ms for a 128 K parameter block.

Table 2-54 lists the flash pin assignments, signal names, and functions.

Table 2-54. Flash Pin Assignments, Schematic Signal Names, and Functions (Part 1 of 3)

Board Reference (U10, U11)	Schematic Signal Name	I/O Standard	Stratix V GX FPGA Device Pin Number	Description
B8	FM_A26	1.8-V	AJ17	Address bus (for pin compatible 1 Gb devices)
B6	FM_A25	1.8-V	AP21	Address bus
H8	FM_A24	1.8-V	AH16	Address bus
G1	FM_A23	1.8-V	AE17	Address bus
A8	FM_A22	1.8-V	AE16	Address bus
C8	FM_A21	1.8-V	AK17	Address bus
C7	FM_A20	1.8-V	AL17	Address bus
B7	FM_A19	1.8-V	AT6	Address bus
A7	FM_A18	1.8-V	AU6	Address bus
D8	FM_A17	1.8-V	AV17	Address bus
D7	FM_A16	1.8-V	AW17	Address bus
C5	FM_A15	1.8-V	AV16	Address bus
B5	FM_A14	1.8-V	AW16	Address bus
A5	FM_A13	1.8-V	AU17	Address bus
C4	FM_A12	1.8-V	AU16	Address bus
D3	FM_A11	1.8-V	AR17	Address bus
C3	FM_A10	1.8-V	AT17	Address bus
B3	FM_A9	1.8-V	AN16	Address bus
A3	FM_A8	1.8-V	AP16	Address bus
C2	FM_A7	1.8-V	AM17	Address bus
A2	FM_A6	1.8-V	AN17	Address bus
D2	FM_A5	1.8-V	AG16	Address bus
D1	FM_A4	1.8-V	AF16	Address bus
C1	FM_A3	1.8-V	AL16	Address bus
B1	FM_A2	1.8-V	AM16	Address bus
A1	FM_A1	1.8-V	AV19	Address bus

Table 2-54. Flash Pin Assignments, Schematic Signal Names, and Functions (Part 2 of 3)

Board Reference (U10, U11)	Schematic Signal Name	I/O Standard	Stratix V GX FPGA Device Pin Number	Description
U11.E7	FM_D31	1.8-V	AT24	Data bus
U11.G7	FM_D30	1.8-V	AV25	Data bus
U11.H5	FM_D29	1.8-V	AW25	Data bus
U11.F5	FM_D28	1.8-V	AL25	Data bus
U11.F4	FM_D27	1.8-V	AL24	Data bus
U11.F3	FM_D26	1.8-V	AJ24	Data bus
U11.E3	FM_D25	1.8-V	AK24	Data bus
U11.E1	FM_D24	1.8-V	AH24	Data bus
U11.H7	FM_D23	1.8-V	AG24	Data bus
U11.G6	FM_D22	1.8-V	AD24	Data bus
U11.G5	FM_D21	1.8-V	AE24	Data bus
U11.E5	FM_D20	1.8-V	AE25	Data bus
U11.E4	FM_D19	1.8-V	AF25	Data bus
U11.G3	FM_D18	1.8-V	AB24	Data bus
U11.E2	FM_D17	1.8-V	AC24	Data bus
U11.F2	FM_D16	1.8-V	AN24	Data bus
U10.E7	FM_D15	1.8-V	AM25	Data bus
U10.G7	FM_D14	1.8-V	AN25	Data bus
U10.H5	FM_D13	1.8-V	AN25	Data bus
U10.F5	FM_D12	1.8-V	AL20	Data bus
U10.F4	FM_D11	1.8-V	AL21	Data bus
U10.F3	FM_D10	1.8-V	AJ20	Data bus
U10.E3	FM_D9	1.8-V	AJ21	Data bus
U10.E1	FM_D8	1.8-V	AK21	Data bus
U10.H7	FM_D7	1.8-V	AL22	Data bus
U10.G6	FM_D6	1.8-V	AE20	Data bus
U10.G5	FM_D5	1.8-V	AE21	Data bus
U10.E5	FM_D4	1.8-V	AH21	Data bus
U10.E4	FM_D3	1.8-V	AG21	Data bus
U10.G3	FM_D2	1.8-V	AD20	Data bus
U10.E2	FM_D1	1.8-V	AD21	Data bus
U10.F2	FM_D0	1.8-V	AN21	Data bus
E6	FLASH_CLK	1.8-V	AM8	Clock
U10.B4	FLASH_CEn0	1.8-V	AV14	Chip enable
U11.B4	FLASH_CEn1	1.8-V	AW13	Chip enable
F8	FLASH_OEn	1.8-V	AJ7	Output enable
F6	FLASH_ADVn	1.8-V	AP7	Address valid
U10.F7	FLASH_RDYBSYn0	1.8-V	AL6	Ready

Table 2-54. Flash Pin Assignments, Schematic Signal Names, and Functions (Part 3 of 3)

Board Reference (U10, U11)	Schematic Signal Name	I/O Standard	Stratix V GX FPGA Device Pin Number	Description
U11.F7	FLASH_RDYBSYn1	1.8-V	AN7	Ready
D4	FLASH_RESETh	1.8-V	AJ6	Reset
G8	FLASH_WEn	1.8-V	AN8	Write enable
C6	FLASH_WPn	—	—	Write protect

Table 2-55 lists the flash memory component reference and manufacturing information.

Table 2-55. Flash Memory Component Reference and Manufacturing Information

Board Reference	Description	Manufacturer	Manufacturing Part Number	Manufacturer Website
U10, U11	512-Mbit synchronous flash	Numonyx	PC28F512P30BF	www.numonyx.com

Power Supply

The development board's power is provided through a laptop style DC power input or through the PCI Express edge connector. The input voltage must be 19 V. The DC voltage is then stepped down to the various power rails used by the components on the board and installed into the HSMC connectors.

An on-board multi-channel analog-to-digital converter (ADC) measures both the voltage and current for several specific board rails. The power utilization is displayed in a GUI that graphs power consumption versus time.

Table 2-56 lists the maximum allowed draws of the power input.

Table 2-56. Power Input Maximum Allowed Draws

Source	Voltage (V)	Current (A)	Maximum Voltage (V)
25 W PCI Express edge connector	3.3	—	—
	12.0	—	—
75 W PCI Express edge connector	3.3	3.00	9.0
	12.0	5.50	66.0
Laptop Supply—DC input	19.0	6.30	120.0

Power Distribution System

The power tree minimizes power board space for PCI Express board requirements and gives the maximum power under 5.5 A for a 12 V PCI Express input and 3.0 A for a 3.3 V PCI Express rail. The switching regulators are assumed to have 85% of efficiency. Regulator inefficiencies and sharing are reflected in the currents shown, which are conservative absolute maximum levels.

Figure 2-10 shows the power distribution system on the development board.

Figure 2-10. Power Distribution System

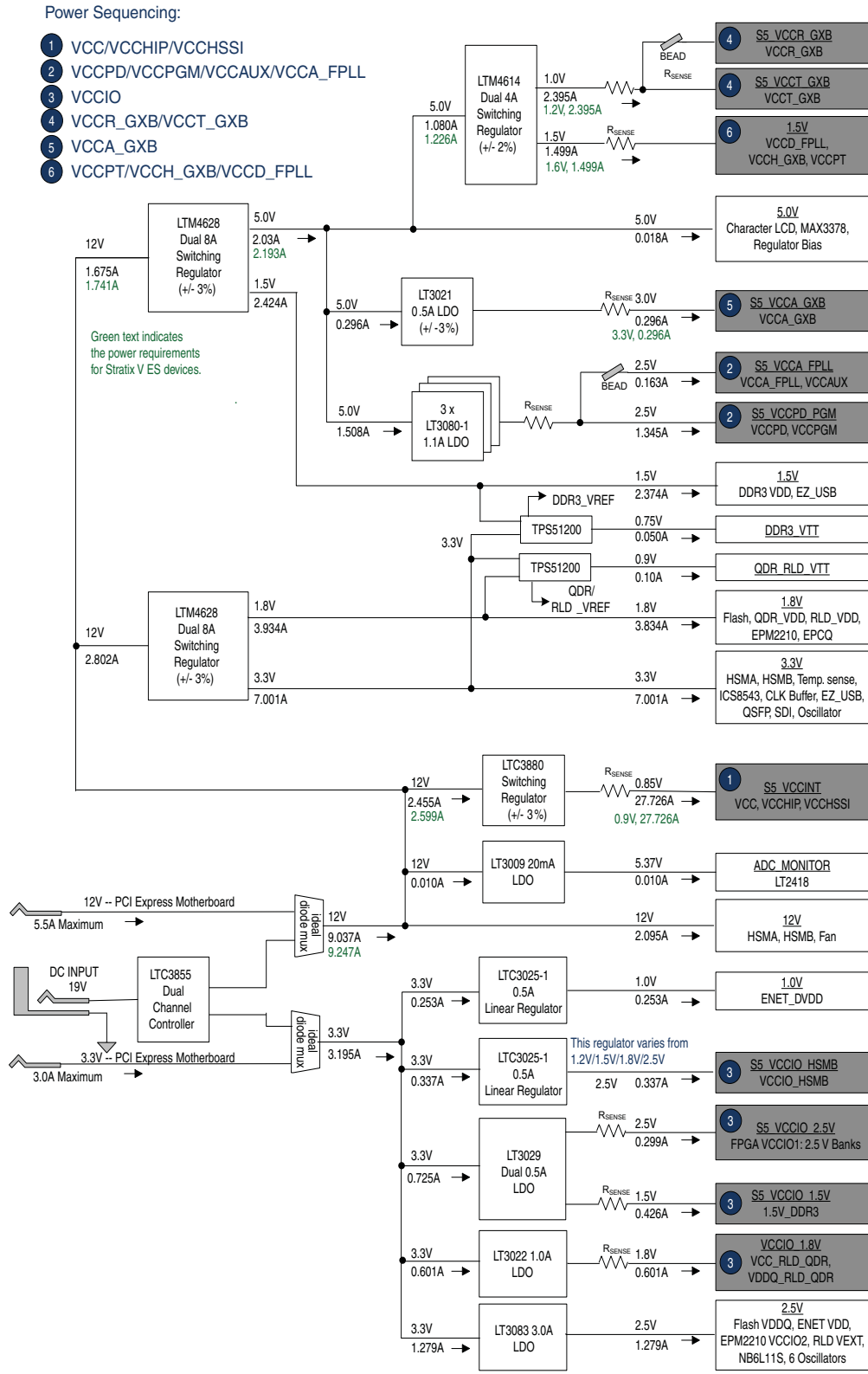

Power Measurement

There are 16 power supply rails which have on-board voltage, current, and wattage sense capabilities. These 8-channel differential 24-bit ADC devices and rails are split from the primary supply plane by a low-value sense resistor for the ADC to measure voltage and current. A serial peripheral interface (SPI) bus connects these ADC devices to the MAX V CPLD System Controller as well as the Stratix V GX FPGA.

Figure 2-11 shows the block diagram for the power measurement circuitry.

Figure 2-11. Power Measurement Circuit

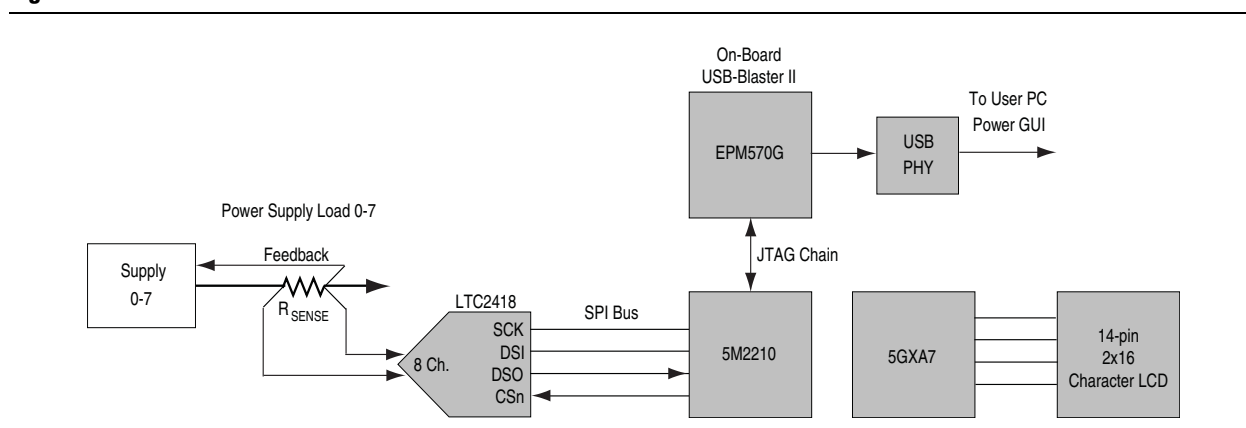

Table 2-57 lists the targeted rails. The schematic signal name specifies the name of the rail being measured and the device pin specifies the devices attached to the rail. If no subnet is named, the power is the total output power for that voltage.

Table 2-57. Power Rail Measurements Based on the GUI Selection (Part 1 of 2)

Number	Schematic Signal Name	Voltage (V)	Device Pin	Description
0	S5_VCCIO_HSMB	1.2/1.5/1.8/2.5	VCCIO_7A	I/O supply bank 7A
			VCCIO_7C	I/O supply bank 7C (HSMC Port B)
			VCCIO_7D	I/O supply bank 7D (HSMC Port B)
1	S5_VCC_GXB	1.1	VCCR_GXB	XCVR analog receive
			VCCT_GXB	XCVR analog transmit
2	S5_VCCIO_1.8V	1.8	VCCIO_3C	I/O supply bank 3C
			VCCIO_3D	I/O supply bank 3D
			VCCIO_4A	I/O supply bank 4A
			VCCIO_4C	I/O supply bank 4C (QDR II/+)
			VCCIO_4D	I/O supply bank 4D (QDR II/+)
3	S5_VCCPD_PGM	2.5	VCCPD	I/O pre-drivers
			VCCPGM	Configuration I/O
			VCCAUX	Programmable power tech auxiliary
			VCCA_FPLL	PLL analog power
4	S5_VCCINT	0.90	VCC	FPGA core and periphery power
			VCCHIP	PCIe Hard IP digital power
			VCCHSSI	PCS power

Table 2-57. Power Rail Measurements Based on the GUI Selection (Part 2 of 2)

Number	Schematic Signal Name	Voltage (V)	Device Pin	Description
5	S5_VCC_1p5	1.5	VCCD_FPLL	PLL digital power
			VCCH_GXB	XCVR block level transmit buffers
			VCCPT	Programmable power tech auxiliary
6	S5_VCCIO_2.5V	2.5	VCCIO_3A	I/O supply bank 3A
			VCCIO_3B	I/O supply bank 3B
			VCCIO_4B	I/O supply bank 4B (HSMC Port A)
			VCCIO_7B	I/O supply bank 7B (HSMC Port A)
7	S5_VCCIO_1.5V	1.5	VCCIO_8A	I/O supply bank 8A (DDR3 RZQ)
			VCCIO_8B	I/O supply bank 8B (DDR3)
			VCCIO_8C	I/O supply bank 8C (DDR3)
			VCCIO_8D	I/O supply bank 8D (DDR3)
8	S5_VCCA_GXB	3.3	VCCA_GXB	XCVR TX driver, RX receiver, CDR

Table 2-58 lists the power measurement ADC component references and manufacturing information.

Table 2-58. Power Measurement ADC Component References and Manufacturing Information

Board Reference	Description	Manufacturer	Manufacturing Part Number	Manufacturer Website
U52	8-channel differential 24-bit ADC	Linear Technology	LTC2418CGN#PBF	www.linear.com
U1	1-channel differential 14-bit ADC	Linear Technology	LTC2990IMS#PBF	www.linear.com

Temperature Sense

Temperature monitoring for the Stratix V GX FPGA die is achieved with a MAX1619 temperature sense device. The MAX1619 device connects to the MAX V CPLD EPM2210 System Controller and the Stratix V GX FPGA device by a 2-wire SMB interface. The MAX1619 device is located at address 0x1. This bus is also routed to a single voltage and power monitor chip for the 12-V power rail at address 0x2.

The OVERTEMP_n and TSENSE_ALERT_n signals are driven by the MAX1619 temperature sense device based on a programmable threshold temperature. The OVERTEMP_n signal is driven to the MAX V System Controller which controls OVERTEMP_n. The MAX V System Controller can control fan speed based on a register setting and can also override the MAX1619 device. For more information on this control, refer to the MAX V System Controller source code found in the development board installation directory <install_dir>\stratixV_GX_fpga\examples\max5.



For more information on the development board installation directory, refer to the *Stratix V FPGA Development Kit User Guide*.

The remote sense routes to the FPGA's diode pins to measure the voltage drop. For very accurate temperature readings, the I/O adjacent to the FPGA diode sense pins must be halted.

Table 2-59 lists the temperature sense interface pin assignments, signal names, and functions.

Table 2-59. Temperature Sense Pin Assignments, Schematic Signal Names, and Functions

Board Reference (U45)	Schematic Signal Name	I/O Standard	MAX V CPLD System Controller Pin Number	Stratix V GX FPGA Device Pin Number	Description
14	SENSE_SMB_CLK	2.5-V	D8	—	SMB clock
12	SENSE_SMB_DATA		A7	—	SMB data
11	TSENSE_ALERTn		B5	—	Programmable over temperature alert
9	OVERTEMPn		C8	—	Fan enable
3	TEMPDIODE_P		—	R6	Temperature sense diode input
4	TEMPDIODE_N		—	P5	Temperature sense diode input

Table 2-60 lists the temperature sense component reference and manufacturing information.

Table 2-60. Temperature Sense Component Reference and Manufacturing Information

Board Reference	Description	Manufacturer	Manufacturing Part Number	Manufacturer Website
U45	Temperature sense, remote and local, programmable alert.	Maxim	MAX1619MEE+T	www.maxim-ic.com



Statement of China-RoHS Compliance

Table 2-61 lists hazardous substances included with the kit.

Table 2-61. Table of Hazardous Substances' Name and Concentration *Notes (1), (2)*

Part Name	Lead (Pb)	Cadmium (Cd)	Hexavalent Chromium (Cr6+)	Mercury (Hg)	Polybrominated biphenyls (PBB)	Polybrominated diphenyl Ethers (PBDE)
Stratix V GX development board	X*	0	0	0	0	0
19 V power supply	0	0	0	0	0	0
Type USB-A to micro USB-B cable	0	0	0	0	0	0
User guide	0	0	0	0	0	0

Notes to Table 2-61:

- (1) 0 indicates that the concentration of the hazardous substance in all homogeneous materials in the parts is below the relevant threshold of the SJ/T11363-2006 standard.
- (2) X* indicates that the concentration of the hazardous substance of at least one of all homogeneous materials in the parts is above the relevant threshold of the SJ/T11363-2006 standard, but it is exempted by EU RoHS.

This appendix catalogs revisions to the Stratix V GX FPGA development board.

[Table A-1](#) lists the versions of all releases of the Stratix V GX FPGA development board.

Table A-1. Stratix V GX FPGA Development Board Revision History

Version	Release Date	Description
Engineering silicon	August 2011	Initial release.

This chapter provides additional information about the document and Altera.

Document Revision History

The following table shows the revision history for this document.

Date	Version	Changes
March 2012	1.2	Updated the DDR3 interface frequency rate to 800 MHz.
October 2011	1.1	<ul style="list-style-type: none"> ■ Updated the transceiver speed to 12.5 Gbps. ■ Revised the FPGA device pin numbers that connect to the on-board oscillator signals: <ul style="list-style-type: none"> ■ CLKINBOT_P0: Changed from AV29 to AH 22 ■ CLKINBOT_N0: Changed from AW29 to AJ22 ■ CLK_125_P: Changed from AH22 to AV29 ■ CLK_125_N: Changed from AJ22 to AW29 ■ Revised the FPGA device pin number that connects to the PCI Express SMB clock signal, PCIE_SMBCLK—changed from AP34 to AN33. ■ Revised the FPGA device pin numbers that connect to the Ethernet PHY signals: <ul style="list-style-type: none"> ■ ENET_RX_P: Changed from AU24 to AP34 ■ ENET_RX_N: Changed from AU25 to AR34 ■ Corrected the FPGA device pin numbers that connect to the SDI video output/input interface signals: <ul style="list-style-type: none"> ■ SDI_TX_P: Changed from F38 to E36 ■ SDI_TX_N: Changed from F39 to E37 ■ SDI_RX_P: Changed from E36 to F38 ■ SDI_RX_N: Changed from E37 to F39 ■ Updated Figure 2-5. ■ Updated Figure 2-10.
August 2011	1.0	Initial release.

How to Contact Altera

To locate the most up-to-date information about Altera products, refer to the following table.

Contact (1)	Contact Method	Address
Technical support	Website	www.altera.com/support
Technical training	Website	www.altera.com/training
	Email	custrain@altera.com
Product literature	Website	www.altera.com/literature
Non-technical support (General) (Software Licensing)	Email	nacomp@altera.com
	Email	authorization@altera.com





Note to Table:

(1) You can also contact your local Altera sales office or sales representative.

Typographic Conventions

The following table shows the typographic conventions this document uses.

Visual Cue	Meaning
Bold Type with Initial Capital Letters	Indicate command names, dialog box titles, dialog box options, and other GUI labels. For example, Save As dialog box. For GUI elements, capitalization matches the GUI.
bold type	Indicates directory names, project names, disk drive names, file names, file name extensions, software utility names, and GUI labels. For example, <code>\qdesigns</code> directory, D: drive, and <code>chiptrip.gdf</code> file.
<i>Italic Type with Initial Capital Letters</i>	Indicate document titles. For example, <i>Stratix IV Design Guidelines</i> .
<i>italic type</i>	Indicates variables. For example, $n + 1$. Variable names are enclosed in angle brackets (< >). For example, <code><file name></code> and <code><project name>.pof</code> file.
Initial Capital Letters	Indicate keyboard keys and menu names. For example, the Delete key and the Options menu.
“Subheading Title”	Quotation marks indicate references to sections within a document and titles of Quartus II Help topics. For example, “Typographic Conventions.”
Courier type	Indicates signal, port, register, bit, block, and primitive names. For example, <code>data1</code> , <code>tdi</code> , and <code>input</code> . The suffix <code>n</code> denotes an active-low signal. For example, <code>reseth</code> . Indicates command line commands and anything that must be typed exactly as it appears. For example, <code>c:\qdesigns\tutorial\chiptrip.gdf</code> . Also indicates sections of an actual file, such as a Report File, references to parts of files (for example, the AHDL keyword <code>SUBDESIGN</code>), and logic function names (for example, <code>TRI</code>).
↵	An angled arrow instructs you to press the Enter key.
1., 2., 3., and a., b., c., and so on	Numbered steps indicate a list of items when the sequence of the items is important, such as the steps listed in a procedure.
■ ■ ■	Bullets indicate a list of items when the sequence of the items is not important.
	The hand points to information that requires special attention.

Visual Cue	Meaning
	A question mark directs you to a software help system with related information.
	The feet direct you to another document or website with related information.
	A caution calls attention to a condition or possible situation that can damage or destroy the product or your work.
	A warning calls attention to a condition or possible situation that can cause you injury.
	The envelope links to the Email Subscription Management Center page of the Altera website, where you can sign up to receive update notifications for Altera documents.

