

Lower Cost, Higher Performance, and Faster Design

## Industrial Motor Drive on a Single FPGA

Drives and motors are an integral part of industrial equipment from packaging, robotics, computer numerical control (CNC), machine tools, industrial pumps, and fans. Designing next-generation drive systems to lower operating costs requires complex control algorithms at very low latencies as well as a flexible platform to support changing needs and the scalability to design multiple-axis functionality.

### Lower Costs Through Design Integration

- Reduce total cost of ownership with our drive-on-a-chip system:
  - Combines a Cyclone® V FPGA with a high-performance, dual-core ARM® processor subsystem or with our flexible Nios® II soft processor allowing you to tightly couple the processor subsystem with hardware accelerators for motor control
  - Extend functionality by integrating industrial networking, encoder interfaces, I/O, analog interfaces, and logic
- Save board space and reduce power consumption with fewer required components and the ability to support multi-axis control
- Adapt quickly to changing market requirements with less design work through our support for leading industrial Ethernet protocols and I/O standards

### Reduce Time To Market

- Save development time and lower risk in designing product variants by reusing intellectual property (IP) cores and leveraging the ARM ecosystem
- Reduce your safety certification time by up to 24 months with our TÜV Rheinland-qualified IEC 61508 Functional Safety FPGA data package

### Meeting Higher-Performance Drive Requirements

- Implement control-loop algorithm latencies of less than 5  $\mu$ s using our variable-precision DSP blocks, multipliers, support for floating point, and arithmetic DSP functions
- Optimize your design by partitioning between software and hardware elements using our model-based design methodology with system-level design tools

Traditional drive systems based on ASICs, digital signal processors (DSPs), and microcontroller units lack the performance and flexibility to address these needs. Altera's family of FPGAs provides a scalable platform that can be used to offload control algorithm elements in hardware. You may also integrate the whole drive system with industry-proven processor architectures while supporting multiple types of encoders and Industrial Ethernet protocols. This "drive on a chip" system reduces cost and simplifies development.

**Figure 1: Cyclone V or Cyclone V SoC FPGAs: Single Drive Device Integrates High-Performance Processor Subsystem with Motor Control Algorithm, I/O Logic, Industrial Ethernet Protocols, and Safety Elements**

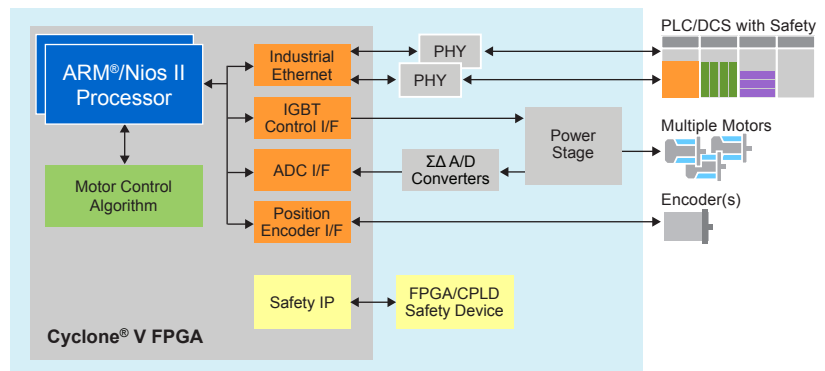

## System-Level Design Flow Tailored for DSP Performance

To optimize your motor control algorithms and designs, you will need versatile tools and a practical design methodology. Figure 2 shows a tool flow that helps model and simulate the system, implement complex algorithms in hardware, partition the hardware/software elements, and fine-tune the performance to the exact needs of the motor drive.

You also can take advantage of easy-to-use development tools, such as Quartus® II design software, and system integration tools, such as Qsys and DSP Builder for DSP optimization. With support for model-based environments such as Simulink®/MATLAB® to model the algorithm, you can integrate a motor control system directly to the DSP Builder tool for the most optimized drive designs. What's more, you can use the familiar tool flow and resources of the rich ARM ecosystem with our SoC FPGAs to reduce development time and take advantage of legacy code.

**Figure 2: System-Level Optimized Design Flow for an SoC FPGA Drive System**

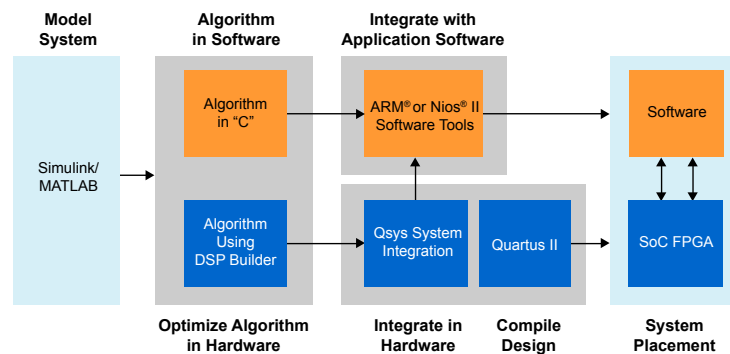

## Altera Cyclone V and Cyclone V SoC FPGA Portfolio

Our Cyclone V and Cyclone V SoC FPGAs join a diverse family of 28-nm FPGAs that are tailored to your design requirements. Cyclone V FPGAs provide the industry's lowest system cost and power, along with multiport memory support such as DDR3/LPDDR, integrated transceiver options, variable-precision DSP blocks, and performance levels that make the device family ideal for differentiating your high-volume applications. You'll also get up to 40 percent lower total power versus the previous generation and efficient logic integration capabilities.

## Want to Dig Deeper?

For more information about Altera's SoC FPGAs for motor control applications, contact your local Altera sales representative or FAE, or visit [www.altera.com/industrial](http://www.altera.com/industrial).

### Altera Corporation

101 Innovation Drive  
San Jose, CA 95134  
USA  
Telephone: (408) 544-7000  
[www.altera.com](http://www.altera.com)

### Altera European Headquarters

Holmers Farm Way  
High Wycombe  
Buckinghamshire  
HP12 4XF  
United Kingdom  
Telephone: (44) 1494 602000

### Altera Japan Ltd.

Shinjuku i-Land Tower 32F  
6-5-1, Nishi-Shinjuku  
Shinjuku-ku, Tokyo 163-1332  
Japan  
Telephone: (81) 3 3340 9480  
[www.altera.co.jp](http://www.altera.co.jp)

### Altera International Ltd.

Unit 11-18, 9/F  
Millennium City 1, Tower 1  
388 Kwun Tong Road  
Kwun Tong  
Kowloon, Hong Kong  
Telephone: (852) 2945 7000

