

Reduced cost, better performance, and greater flexibility

Motor control solutions for industrial applications

Developing motor control and industrial networking solutions using FPGA-based platforms provides more advantages than ever for industrial processes such as production, assembly, packaging, robotics, computer numeric controlled (CNC) machine tools, and printing. Unlike traditional drive solutions using microprocessors, microcontrollers, and digital signal processing (DSP) devices, a design based on a single FPGA platform offers:

- Reduced costs, since the single platform integrates multiple functions and requires less board space and a smaller component count.
- Increased flexibility, because FPGAs can be reprogrammed at any time.
- Enhanced drive performance.
- Reduced time to market, using pre-verified Altera partner solutions for networking/fieldbus communication and drive control.

Typically, the architecture for a motor control application is a feedback system as shown in this diagram.

Motor control architecture

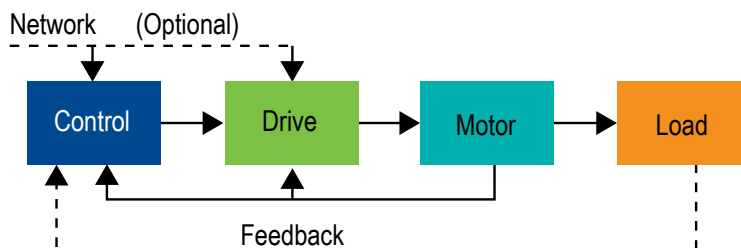

Drive control and Industrial Ethernet on a single FPGA

While microcontrollers and DSP devices may be well suited to certain aspects of motor control systems, they lack flexibility to support motor control IP and interfaces in hard logic.

With our Cyclone® III FPGA, you can integrate processors, digital logic interfaces, DSP functions, motor control IP and multiple Industrial Ethernet protocols into one device, reducing board size and complexity. Operating across industrial communication networks, motion control solutions with drive-controlled motors can be very energy efficient. Aside from saving power, this can also lead to net cost savings in the long run.

For designs requiring high levels of security, Altera also offers the Cyclone III LS variant. These 60-nm FPGAs provide up to 200K logic elements for less than 0.25 Watt of static power, as well as security features that protect against tampering and reverse engineering.

Typical FPGA-based motor/servo control system

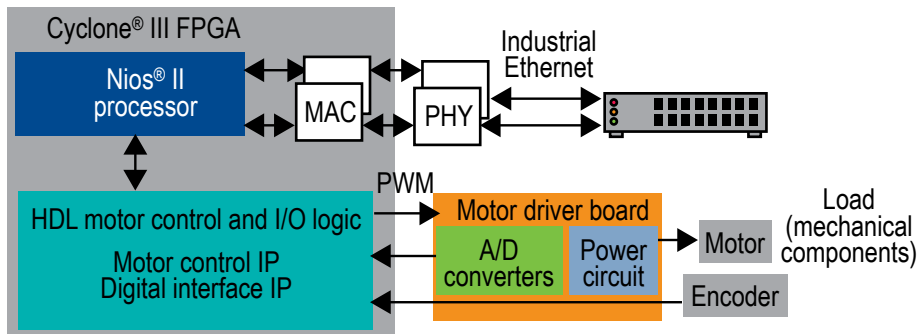

Flexible FPGAs equip you to support the latest sensor interfaces, such as BiSS, EnDaT, or sigma delta, and to connect to as many traditional interfaces (eg. SPI, I2C, UART, PWM, PCI, etc.) as required by your application. Implementing the drive control algorithms in programmable logic offers a significant increase in performance: multiple drives can share the same logic without any loss in drive response.

What's more, FPGAs tend to have long lifetimes, reducing the risk of obsolescence. Since any motor control application developed for an FPGA will be soft intellectual property (IP), you can readily migrate it to new FPGA device families without recoding either your software or hardware.

Development kits for creating motor control systems

Altera, Arrow Electronics, and National Semiconductor have teamed to create a development kit that gives you a platform to support single- or multiple-axis motor control and Industrial Ethernet applications on a Cyclone III FPGA. The MotionFire Motor Control Platform features:

- A FireFighter base board with a Cyclone III EP3C40 FPGA and a FireDriver motor driver board configured to drive brushless direct current (BLDC) motors.
- Optional FireDriver boards (two motors per board), which include an Altera® MAX® II CPLD on the board, to add up to 12 BLDC motors.
- Industrial Ethernet protocol standard from Softing AG.
- OpenFire motor control IP from Unjo AB to control the motor applications.

Available in Europe, the FalconEye motor control development kit from Altera partner EBV Elektronik provides another platform for developing brushless alternating current (AC) and induction motors. Based on a Cyclone III FPGA, the kit consists of a motor, powerstage board, and FPGA board. Additionally, the kit also includes a motor control reference design that implements high-performance, real-time VHDL control hardware on the Cyclone III FPGA and C control software running on a Nios II processor embedded in the FPGA.

Want to dig deeper?

For more information on Altera motor control and other industrial solutions, please visit www.altera.com/industrial or contact your local Altera sales representative.

The MotionFire development kit is available worldwide through Arrow at www.arrow.com/mktg/motionfire, or, for technical information, visit www.motionfire.eu. Contact your Arrow sales representative for more information.

For more information about the FalconEye motor control development kit, please visit www.ebv.com/falconeye. To purchase, contact your EBV sales representative (Europe only).

Altera Corporation
101 Innovation Drive
San Jose, CA 95134
USA
www.altera.com

Altera European Headquarters
Holmers Farm Way
High Wycombe
Buckinghamshire
HP12 4XF
United Kingdom
Telephone: (44) 1 94 602 000

Altera Japan Ltd.
Shinjuku i-Land Tower 32F
6-5-1, Nishi-Shinjuku
Shinjuku-ku, Tokyo 163-1332
Japan
Telephone: (81) 3 3340 9480
www.altera.co.jp

Altera International Ltd.
Unit 11-18, 9/F
Millennium City 1, Tower 1
388 Kwun Tong Road
Kwun Tong
Kowloon, Hong Kong
Telephone: (852) 2945 7000

ALTERA