



Minimize Cost and Power While Enabling Full-Spectrum Modulation

Altera QAM Design Solution for HD Video

The world of television has changed dramatically with the proliferation of high-definition (HD) programming, Video on Demand, and customized services. Service providers are facing new and unique challenges in meeting customers' demands.

It is a challenge to deliver features and programs with the right infrastructure at the right cost. The Altera® quadrature amplitude modulation (QAM) solution provides the lowest power and cost, while offering the bandwidth and processing capability for you to deliver HD video and customized services to many homes.

Lowering Power and Cost While Providing Flexibility

Altera's Arria V® and Stratix® V FPGAs provide the highest efficiency QAM system with the highest number of supported channels. Each QAM channel uses either an LVDS pair of up to 1 Gbps, or a single transceiver pair for faster data rates.

The QAM channels perform scrambling, encoding, grouping, and filtering. By using Altera's 28-nm FPGAs and intellectual property (IP) portfolio to implement your QAM design, you get a solution at the lowest power and cost.

Designing your QAM systems using FPGAs gives you the flexibility to implement new features and services without replacing entire costly systems. Each card in the QAM system and the entire datapath can be designed within the FPGA.

Figure 1: Typical Edge-QAM System Architecture

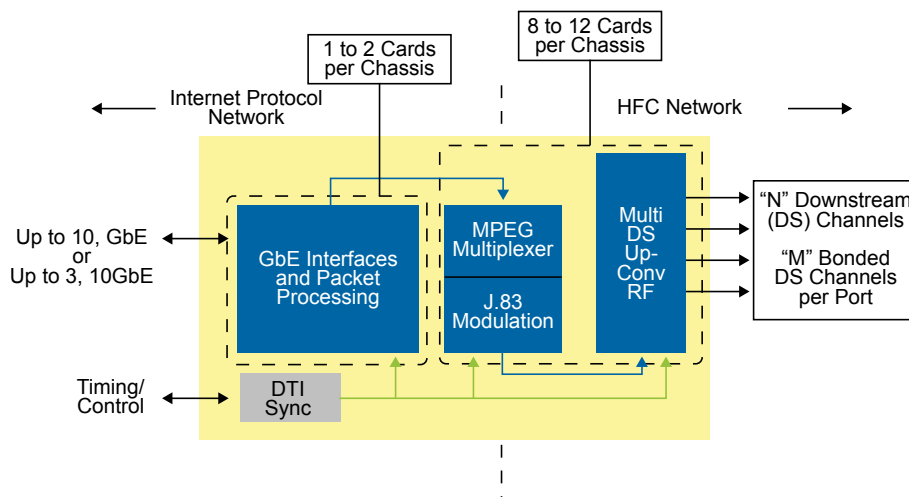
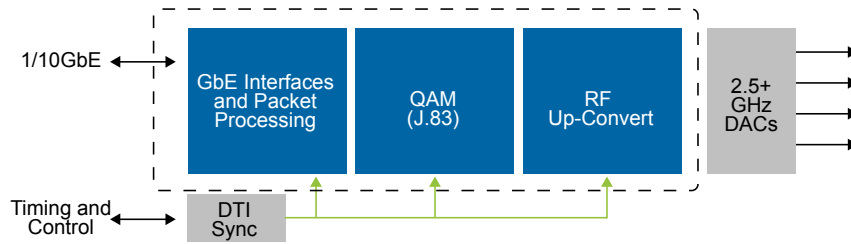

Figure 1: Scalable Edge-QAM Reference Design



Altera's QAM reference design consists of three major blocks – the 10-Gbps Ethernet (10GbE) block, the modulator, and the digital upconverter (DUC).

The Reference Design Offers:

- Scalability of up to 160 channels
- J.83 QAM mapping
- Integrated Gbps Ethernet (GbE) interface and direct interface from the DUC to digital-to-analog converters (DACs)
- DOCSIS 3.0 DRFI compliance
- Fully hardware verified
- Up to 80 dB signal-to-noise ratio on RRC output
- Power consumption of <10W for 160 channel system on Arria V

Want to Dig Deeper?

For more information on Altera's digital QAM solutions, please contact your local Altera FAE sales representative. You can also visit www.altera.com/literature/wp/wpstxiqam.pdf to read the white paper.

Altera Corporation
101 Innovation Drive
San Jose, CA 95134
USA
www.altera.com

Altera European Headquarters
Holmers Farm Way
High Wycombe
Buckinghamshire
HP12 4XF
United Kingdom
Telephone: (44) 1 94 602 000

Altera Japan Ltd.
Shinjuku i-Land Tower 32F
6-5-1, Nishi-Shinjuku
Shinjuku-ku, Tokyo 163-1332
Japan
Telephone: (81) 3 3340 9480
www.altera.co.jp

Altera International Ltd.
Unit 11-18, 9/F
Millennium City 1, Tower 1
388 Kwun Tong Road
Kwun Tong
Kowloon, Hong Kong
Telephone: (852) 2945 7000

