Quality of Service in Home Networking

Introduction

The home network is becoming a “Grand Central Station” for faster video, voice, and data traffic. Demand for a higher data rate is expected to increase as video changes from standard definition to high definition, meaning that home-networking systems must evolve along with emerging video standards. Currently, various interface standards for both wired and wireless networking are used to implement multimedia home networking, but none of these current standards guarantees quality-of-service (QoS) for live multimedia transmission within the home.

Challenges

The first challenge is to design a reliable multimedia home-networking platform that delivers Internet Protocol (IP) packets with sufficient QoS, with no visible or audible distortion. The second challenge is for designers to figure out how to do this cost-effectively to keep the consumer application affordable.

Several techniques are already deployed in the professional broadcast industry to address the first challenge. By implementing those techniques in a consumer-type, low-cost FPGA, designers will be able to meet the second challenge.

Real-Time Transport Protocol

The real-time transport protocol (RTP) is aimed primarily at the transmission and distribution of audio and video over the Internet for applications such as video conferencing and video streaming. However, the protocol is also useful for the distribution of video over Ethernet in more controlled environments, such as home multimedia networking, as it offers features for time stamping and detection of packet loss or reordering.

The Internet Engineering Task Force (IETF)’s Audio/Video Transport (AVT) Working Group defined the RTP for real-time transmission of audio and video over IP. Originally defined in the request for comments (RFC) document RFC3350, it was approved as a full standard by the IETF Internet Engineering Steering Group (IESG) in May 2004. The AVT Working Group is also developing a number of supporting standards for payload formats, error correction, and security.

RTP Payload Format for MPEG/MPEG-2 Video

RTP is a generic protocol suitable for a wide variety of transport applications. It is extended by additional specifications that target more specific applications. RFC2250 defines an RTP payload format for MPEG and MPEG-2 video, with details for the encapsulation of MPEG-2 transport stream (TS) data, and is referenced by the Pro-MPEG Code of Practice #3 (CoP3) and the Digital Video Broadcast (DVB)-IP Handbook.

UDP/IP

RTP is a transport protocol. Most commonly, it uses user datagram protocol (UDP, defined by IETF RFC768), as the host-to-host layer and IP as the Internet layer (defined by IETF RFC791). Unlike the transmission control protocol (TCP), UDP is not connection oriented and offers no facilities for sequencing data or guaranteeing reliable packet delivery. This feature makes it faster, simpler, and more efficient than TCP, and therefore more suitable for high-bandwidth video distribution when combined with RTP.

Pro-MPEG Code of Practice #3 FEC

Whenever data is routed through a wired or wireless network, it is subjected to corruption due to noise, clock jitter, and saturated network links, which translate into packet loss or video pixel loss. This is more obvious in a compressed video stream than an uncompressed video stream.

The Pro-MPEG Forum is an association of broadcasters, program makers, equipment manufacturers, and component suppliers with interests in realizing interoperability of professional television equipment, according to the implementation requirements of broadcasters and other end-users. The Pro-MPEG Wide Area Network (WAN) Working Group focuses on establishing interoperability practices for systems that exchange high-quality programming material over WANs using IP. This group has produced a code of practice for the transmission of professional MPEG-2 TS data over IP networks, which recommends the transmission protocol (for example, RTP/UDP/IP mapping) and a forward error correction (FEC) scheme, and also discusses issues such as timing recovery, jitter tolerance, and latency. The recommendations for the transmission protocol have been followed for the Video Over IP reference design, although the use of RTP is optional to support UDP/IP-based legacy standards.

One method for ensuring a minimum level of data integrity in an IP network environment is to use payload-aware processing. Payload-aware processing involves IP encapsulation, timing correction, and application-layer FEC. Live video transmission cannot use the packet resent method. Therefore, by using FEC, the receiver reconstructs missing or corrupted data on the fly without having to request a retransmission. Various types of FEC schemes are used in cable, satellite, and terrestrial digital video transmission. For IP video networks, the Pro-MPEG Forum proposed a FEC algorithm that uses an exclusive-OR (XOR) method to generate redundant data for error correction. This standard is called the Pro-MPEG COP3 release 2 (CoP3r2). This FEC is used primarily for compressed video streams such as MPEG-2 or H.264.

The Pro-MPEG FEC is a two-dimensional XOR algorithm with several possibilities determining the size of the data matrix. This FEC dictates that the matrix should have at least one and no more than 20 columns with at least four and no more than 20 rows. In addition, the total number of packets in one matrix cannot exceed 100 packets. In order to understand this simple FEC concept, if A and B are RTP packets, then $F = A \oplus B$ is the FEC packet associated to the $\{A, B\}$ protection set. F is the result of the XOR operator byte after byte on both RTP packets. An interesting property of the XOR operator is that if $F = A \oplus B$, then $A = B \oplus F$ and $B = A \oplus F$. If A or B is discarded, then A or B can be recovered using the F FEC packet. Figure 1 shows a Pro-MPEG matrix arrangement with the resulting FEC overhead data shown in green.

Figure 1. Matrix Arrangement Examples

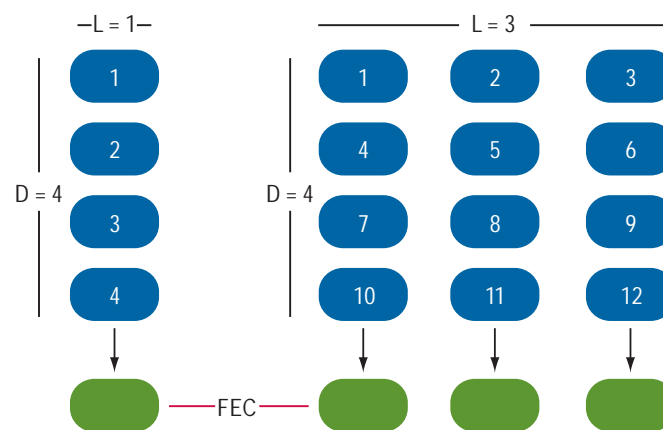

The Altera Solution

The Altera® Video Over IP reference design carries traffic by accepting MPEG TS data from several inputs and encapsulating it for transmission over an Ethernet-based IP network. The design uses industry-standard UDP/IP network encapsulation, with RTP encapsulation and Pro-MPEG CoP3 FEC available as an option. The design supports both 100-Mbps (full duplex) and 1-Gbps Ethernet connections, and can process up to 256 individual streams. By using hardware encapsulation, the design can achieve line-rate Gigabit Ethernet (GbE) performance with minimal transmission latency.

The design also accepts up to 256 individual streams from an Ethernet network and recovers the TS data. For RTP-encapsulated data, the design includes a receiver buffer to absorb network jitter and correct for packet reordering and duplication. CoP3 FEC-based lost-packet recovery is an available option, as well.

Most of the key building blocks are available and can be downloaded for reuse into an FPGA system design. The design can also be built by using existing building blocks in the FPGA design tool. Most design tools contain blocks such as FIFO, internal memories, external memory controllers, counters, phase-locked loops (PLLs), and other simple logic blocks. Figure 2 shows a typical multimedia home networking design using FPGA as a bridging function for interfaces such as USB 2.0 and FireWire, as well as future video interface protocols. The input video can map into the IP networking using Altera's Video Over IP reference design. Low-cost FPGAs such as the Cyclone® series can be used to implement a complete design, giving the system flexibility and upgradeability to meet future requirements.

Figure 2. Typical Multimedia Home Networking

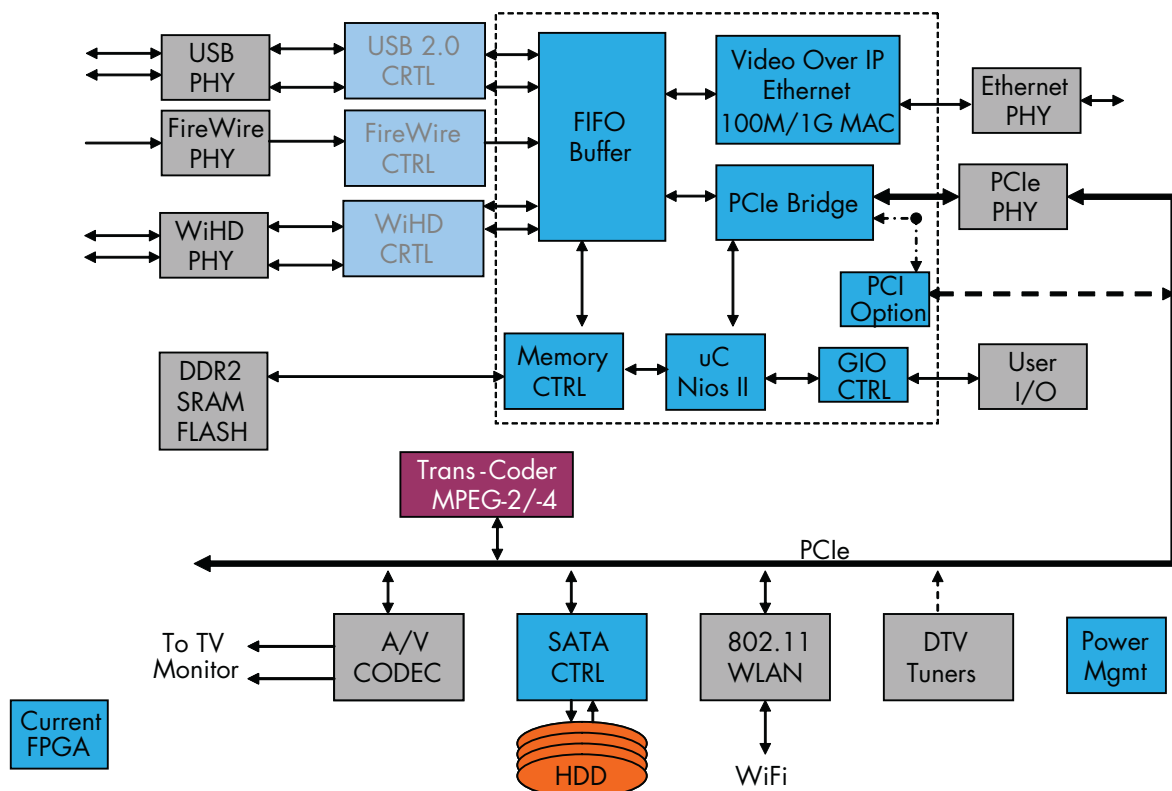

The Video Over IP reference design (shown in Figure 3) is based on the SOPC Builder system, which provides the following key building blocks:

- RTP transmitter
- RTP receiver
- UDP/IP function
- PHY interface
- Nios® II imbedded processor for design control
- Arbitration logic and memory controller for the FEC generator and receiver buffer external RAM.

Figure 3. Video Over IP Reference Design

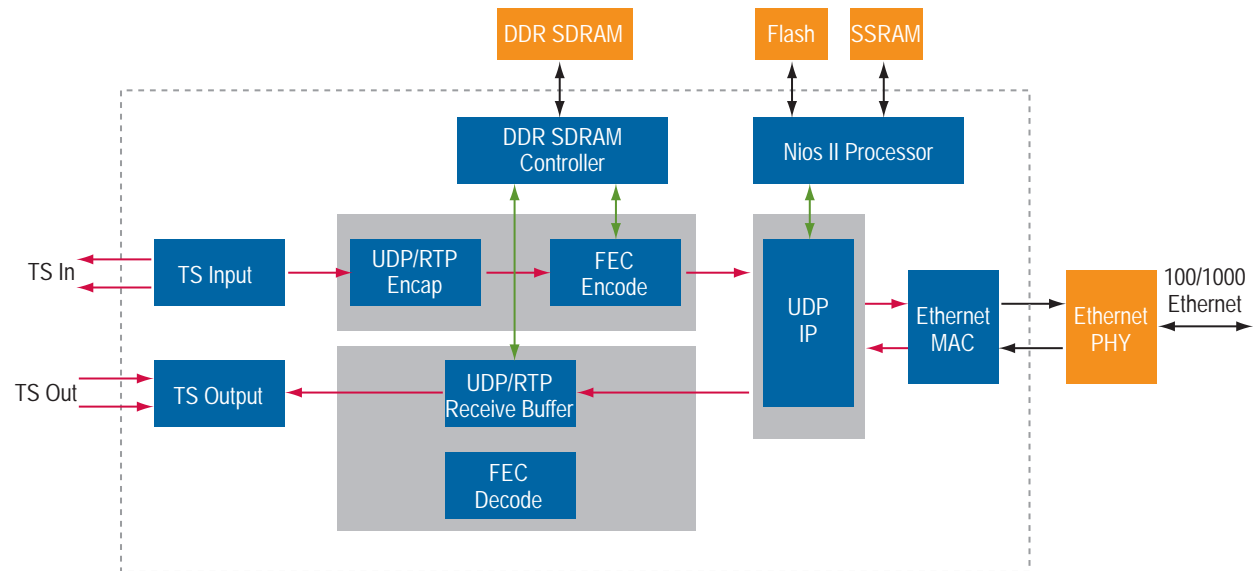

Conclusion

Using existing technology from the broadcast industry, the quality of service for multimedia home networking can be simplified. This technology can easily be implemented using Altera's low-cost Cyclone family of FPGAs with the availability of the Video Over IP reference design. Programmable logic will play an increasing role in this emerging home multimedia networking market due to the variety of different standards.

Further Information

- Video Over IP Reference Design:
www.altera.com/support/refdesigns/sys-sol/broadcast/ref-video.html
- Professional-MPEG Forum's discussion forum:
www.pro-mpeg.org/forum

Acknowledgements

- Tam Do, Senior Technical Marketing Manager, Broadcast/Automotive/Consumer Business Unit, Altera Corporation



101 Innovation Drive
San Jose, CA 95134
www.altera.com

Copyright © 2010 Altera Corporation. All rights reserved. Altera, The Programmable Solutions Company, the stylized Altera logo, specific device designations, and all other words and logos that are identified as trademarks and/or service marks are, unless noted otherwise, the trademarks and service marks of Altera Corporation in the U.S. and other countries. All other product or service names are the property of their respective holders. Altera products are protected under numerous U.S. and foreign patents and pending applications, maskwork rights, and copyrights. Altera warrants performance of its semiconductor products to current specifications in accordance with Altera's standard warranty, but reserves the right to make changes to any products and services at any time without notice. Altera assumes no responsibility or liability arising out of the application or use of any information, product, or service described herein except as expressly agreed to in writing by Altera Corporation. Altera customers are advised to obtain the latest version of device specifications before relying on any published information and before placing orders for products or services.