

General Description

The SD/MMC SPI Core with Avalon Interface allows you to easily connect SOPC Builder systems to standard MultiMedia™ Card (MMC) and Secure Digital Card (SD) flash based memory devices. The MultiMediaCard and SD-Cards are universal, low cost data storage and communication media, which are generally available and widely used in consumer products such as digital cameras or cellular phones. The SD/MMC SPI Core is fully compliant with SOPC Builder and integrates easily into any SOPC Builder generated system.

For the NIOS II processor, El Camino provides low-level driver routines for the SD/MMC SPI Core. The drivers provide universal access routines for MMC and SD memory devices. Therefore you do not need to write any additional low level code to read or write raw data from or to MMC/SD cards.

Figure 1: Block Diagram

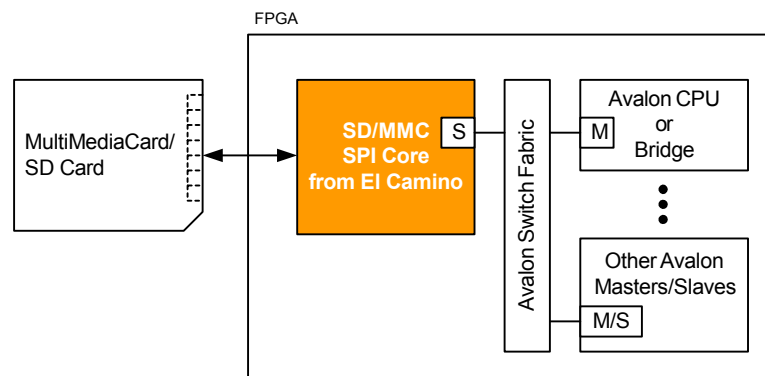

Features

- Supports MultiMediaCard (MMC) and Secure Digital Card (SD) in SPI mode
- Variable data rate up to 20 Mbps
- Hardware assisted CRC calculation
- Low-level drivers included
- Windows utility for raw data read/write access on PC platform
- Comes with prototyping adapter for Altera and El Camino NIOS development boards

Applications

The SD/MMC SPI Core is ideal for applications where a mobile, standard and exchangeable storage media is required for NIOS II applications. Together with the provided Windows utility it is easy to exchange raw data between a NIOS application and the PC platform.

When used together with the El Camino SD/MMC loader, FPGA configuration data can be combined with application data or program storage on a removable, common and compact storage media.

Deliverables

- SOPC Builder ready IP core in VHDL
- Low-level software drivers for initialization, read and write access
- Prototyping adapter for Altera and El Camino Nios prototyping boards

Architecture Specification

Figure 2: SD/MMC SPI Core Block Diagram

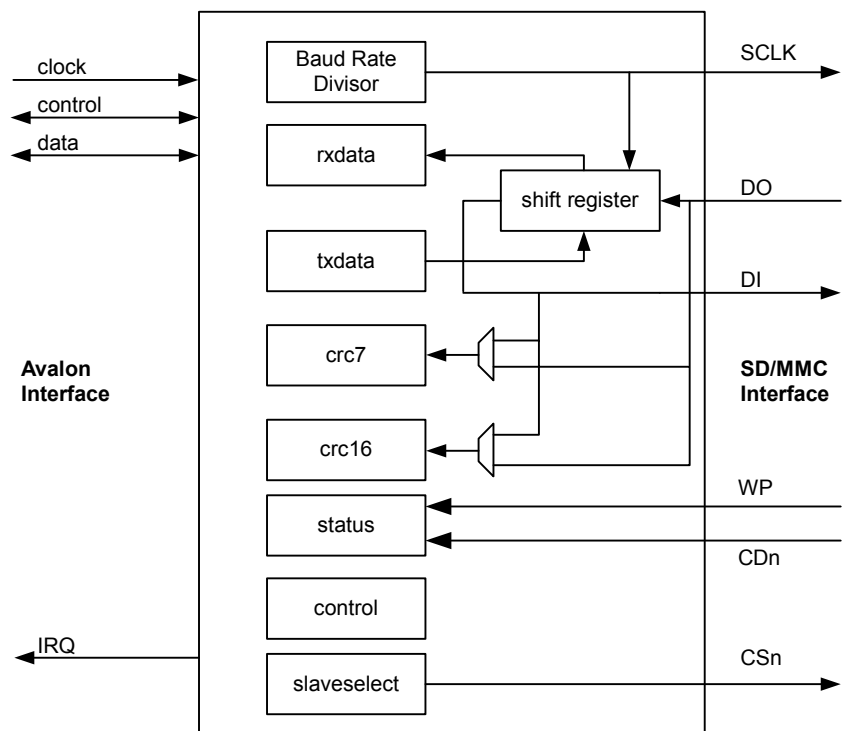

The SD/MMC SPI core has the following user visible features:

- A memory-mapped register space comprised of 7 registers:
 - rxdata, txdata
 - status, control, slaveselect
 - crc7, crc16

- Six SD/MMC card interface ports:
 - SCLK, CSn
 - DI, DO
 - WP, CDn

The registers provide an interface to the SD/MMC SPI core and are visible via the Avalon slave port. The clk, cs_n, DataIn, DataOut, write_protect and card_detect ports provide the hardware interface to the SD/MMC card.

The core logic is synchronous to the clock input provided by the Avalon interface. The Avalon clock is divided to generate the SD/MMC CLK output.

Table 1: Port Description

Port	Direction	Function
SCLK	output	Clock Signal to the SD/MMC card. This clock is derived from the system clock by a parameterizable clock divider. The frequency determines the data rate and must be set in the SOPC builder
DI	output	Data in port to the SD/MMC card (host to card commands and data)
DO	input	Data out port from the SD/MMC card (card to host data and status)
CSn	output	Chip select (active low) to the SD/MMC card
CDn	input	card detect input from the SD/MMC card connector, mapped into the status register
WP	input	write protect input from the SD/MMC card connector, mapped into the status register

Table 2: SOPC Builder Settings

Parameter	Legal Values	Default	Description
SPI_Data_Rate	<10 MHz	10	The SPI_Data_Rate value is used to calculate an appropriate clock divisor value to implement the desired SPI Data Rate. The resulting effective SPI Data Rate is reported in the SOPC Builder and will be less or equal the desired SPI Data Rate. The effective data rate will depend on the relationship between the desired data rate and the actual system clock frequency. The achievable data rate values are: <Avalon system clock frequency> / [2,4,6,8,...]
Enable CRC	checked/ unchecked	checked	Turns on CRC checking during read and write operations

Figure 3: SOPC Builder GUI



Figure 4: Connecting the SD/MMC SPI Core

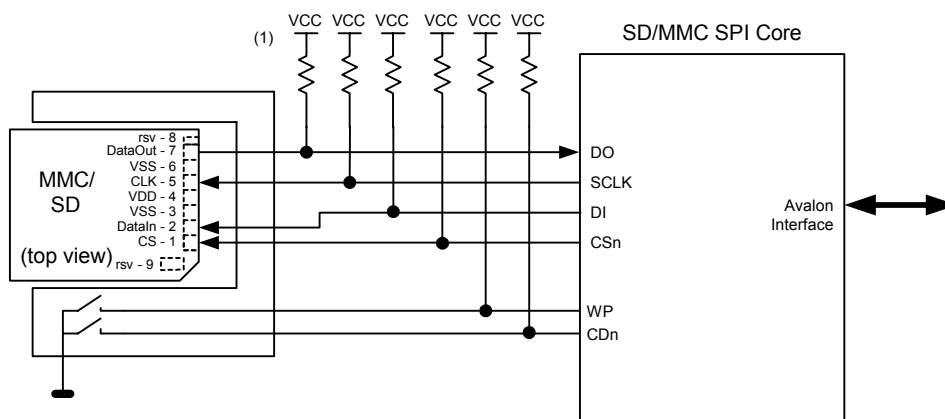

(1) Pull-up resistors are 10kOhm

Register Model

An Avalon master peripheral controls and communicates with the SD/MMC SPI core via the 7 16-bit registers, shown in the following table:

Table 3: Register Map for SD/MMC IP Core

Internal Address	Register Name	15..12	11	10	9	8	7	6	5	4	3	2	1	0	
0	rxdata							RXDATA							
1	txdata							TXDATA							
2	status (1)		CD			E	RRDY	TRDY	TMT	TOE	ROE		WP	MS	
3	control		ICD	SSO		IE	IRRDY	ITRDY		ITOE	IROE	CRC DIR	CRC CLEAR	CNT START	
4	crc7							CRC7							1
5	slaveselect													SELECT	
6	reserved	reserved													
7	crc16	CRC16													

(1) A write operation to the status register clears the roe, toe and e bits

rxdata Register

A master peripheral reads received data from the rxdata register. When the receive shift register receives a full 8 bits of data, the status register's rrdy bit is set to 1 and the data is transferred into the rxdata register. Reading the rxdata register clears the rrdy bit. Writing to the rxdata register has no effect. New data is always transferred into the rxdata register, whether or not the previous data was retrieved. If rrdy is 1 when data is transferred into the rxdata register (i.e., the previous data was not retrieved), a receive overrun error occurs and the status register's roe bit is set to 1. In this case, the contents of rxdata are undefined.

txdata Register

A master peripheral writes data to be transmitted into the txdata register. When the status register's trdy bit is 1, it indicates that the txdata register is ready for new data. The trdy bit is set to 0 whenever the txdata register is written. The trdy bit is set to 1 after data is transferred from the txdata register into the transmitter shift register, which readies the txdata holding register to receive new data.

A master peripheral should not write to the txdata register until the transmitter is ready for new data. If trdy is 0 and a master peripheral writes new data to the txdata register, a transmit-overrun error occurs and the status register's toe bit is set to 1. In this case, the new data is ignored, and the content of txdata remains unchanged.

As an example, assume that the SD/MMC SPI core is idle (i.e., the tx-

data register and transmit shift register are empty), when a CPU writes a data value into the txdata holding register. The trdy bit is set to 0 momentarily, but after the data in txdata is transferred into the transmitter shift register, trdy returns to 1. The CPU writes a second data value into the txdata register, and again the trdy bit is set to 0. This time the shift register is still busy transferring the original data value, so the trdy bit remains at 0 until the shift operation completes. When the operation completes, the second data value is transferred into the transmitter shift register and the trdy bit is again set to 1.

status Register

The status register consists of bits that indicate status conditions in the SD/MMC SPI core. Each bit is associated with a corresponding interrupt-enable bit in the control register, as discussed in “control Register”. A master peripheral can read status at any time without changing the value of any bits. Writing status does clear the roe, toe and e bits. The next table describes the individual bits of the status register.

Table 4: status Register Bits

#	Name	Description
0	MS	Millisecond Timer One millisecond after the CNT START bit in the control register was set to 1 this bit is set to 1. This bit is automatically reset after reading from the status register.
1	WP	Write Protect The WP bit mirrors the status of the write protect input of the SD/MMC core.
3	ROE	Receive-overflow error The ROE bit is set to 1 if new data is received while the rxdata register is full (that is, while the RRDY bit is 1). In this case, the new data overwrites the old. Writing to the status register clears the ROE bit to 0.
4	TOE	Transmitter-overflow error The TOE bit is set to 1 if new data is written to the txdata register while it is still full (that is, while the TRDY bit is 0). In this case, the new data is ignored. Writing to the status register clears the TOE bit to 0.
5	TMT	Transmitter shift-register empty The TMT bit is set to 0 when a transaction is in progress and set to 1 when the shift register is empty.
6	TRDY	Transmitter ready The TRDY bit is set to 1 when the txdata register is empty.
7	RRDY	Receiver ready The RRDY bit is set to 1 when the rxdata register is full.
8	E	Error The E bit is the logical OR of the TOE and ROE bits. This is a convenience for the programmer to detect error conditions. Writing to the status register clears the E bit to 0.
11	CD	Card Detect The CD bit mirrors the status of the card detect input of the SD/MMC core.

control Register

The control register consists of data bits to control the SD/MMC SPI core’s operation. A master peripheral can read the control register at any

time without changing the value of any bits. Most bits (ICD, IROE, ITOE, ITRDY, IRRDY, and IE) in the control register control interrupts for status conditions represented in the status register. For example, bit 1 of status is ROE (receiver-overflow error), and bit 1 of control is IROE, which enables interrupts for the ROE condition. The SPI core asserts an interrupt request when the corresponding bits in status and control are both 1. The next table describes the individual bits of the control register.

Table 5: control Register Bits

#	Name	Description
0	CNT START	Counter Start Writing a 1 to this bit starts a one millisecond counter. When the counter expires the MS bit is set in the status register.
1	CRC CLEAR	CRC Register Clear This bit resets the CRC7 and CRC16 registers and prepares new CRC calculations base on the data sent or received by the core.
2	CRC DIR	CRC Direction This bit connects the CRC7 and CRC16 registers to either the transmit or receive channel. Setting this bit to 1 calculates CRCs on outgoing data. Setting this bit to 0 calculates CRCs on incoming data.
3	IROE	Setting IROE to 1 enables interrupts for receive-overflow errors.
4	ITOE	Setting ITOE to 1 enables interrupts for transmitter-overflow errors.
6	ITRDY	Setting ITRDY to 1 enables interrupts for transmitter ready conditions.
7	IRRDY	Setting IRRDY to 1 enables interrupts for the receiver ready condition.
8	IE	Setting IE to 1 enables interrupts for any error condition
10	SSO	Setting SSO to 1 forces the SD/MMC SPI core to drive its cs_n output, regardless of whether a serial shift operation is in progress or not. The slaveselect register controls which cs_n outputs are asserted. sso can be used to transmit or receive data of arbitrary size (i.e., greater than 16 bits).
11	ICD	Setting ICD to 1 enables interrupts for card detect conditions

After reset, all bits of the control register are set to 0. All interrupts are disabled and no cs_n signal is asserted after reset.

slaveselect Register

The slaveselect register is a bit mask for the cs_n signals driven by SD/MMC SPI core. The core has only one cs_n output mapped to bit 0 of the slaveselect register. During a serial shift operation, the SPI master selects only the slave device(s) specified in the slaveselect register. Upon reset, bit 0 is set to 1, and all other bits are cleared to 0. Thus, after a device reset, the SD/MMC card is automatically selected.

Resource Utilization and Performance

The following results are based on synthesis and place & route in Quartus II Version 5.0. The maximum frequency of the data transfer is limited by both the maximum system frequency of the SOPC builder block and the maximum SCLK frequency of the SD/MMC card.

Table 6: Resources

Device Family	Ressource
Cyclone	269 Logic Elements
Cyclone II	268 Logic Elements
Stratix	269 Logic Elements
Stratix II	254 ALUTs

Software Support

Basic Concept

The SD/MMC SPI peripheral is integrated into the HAL generic device model classes as a FLASH memory device.

The HAL provides a generic device model for nonvolatile flash memory devices such as SD/MMC cards. The HAL API provides functions to write data to flash. For example, you can use these functions to implement a SD/MMC-based filing subsystem.

Although it is not necessary for general, parallel FLASH devices, the HAL API also provides functions to read flash. For most flash devices, programs can treat the flash memory space as simple memory when reading, and do not need to call special HAL API functions. If the flash device has a special protocol for reading data, just like SD/MMC cards, you must use the HAL API to both read and write data.

The following two NIOS II HAL APIs provide a different level of access to the flash:

- **Simple flash access**
a simple API for writing buffers into flash and reading them back, which in general does not preserve the prior contents of other flash erase blocks.
- **Fine-grained flash access**
finer-grained functions for programs that need control over writing or erasing individual blocks. This functionality is generally required for managing a file subsystem.

With SD/MMC cards you can write single bytes without the need to erase whole blocks or sectors. So even when using simple flash access all data within a sector or block is preserved even when not writing the complete sector or block. Only for compatibility reasons with other

flash devices it might make sense to use fine-grained flash access even with SD/MMC cards.

The API functions for accessing flash devices are defined in `sys/alt_flash.h`.

Simple Flash Access

This interface comprises:

`alt_flash_open_dev()`, `alt_write_flash()`, `alt_read_flash()`, and `alt_flash_close_dev()`.

Writing and Reading can start at any address and can be of any length as long as one stays within the boundaries of the SD/MMC card. For maximum compatibility with older SD/MMC cards however it is recommended to start writing only on block boundaries. The block size can be determined with the „`alt_get_flash_info()`“ function. The typical block size for most SD/MMC cards is 512 bytes.

The code “Example: Using the Simple Flash API Functions” in the Nios II Software Developer's Handbook shows the usage of all of these functions in one code example.

Fine Grained Flash Access

There are three additional functions that provide complete control over writing flash contents at the highest granularity:

`alt_get_flash_info()`, `alt_erase_flash_block()`, and `alt_write_flash_block()`.

These functions are implemented for compatibility reasons with other flash devices however are not necessary when accessing SD/MMC cards.

Command Line Tool

The utility „sd_rd_wr“ allows to read and write raw data from and to SD or MMC cards. The tool provides its own documentation in the form of a help page, accessible from the command line. To view the help, open a DOS Command Shell, and type the following command:

```
sd_rd_wr -h
```

Usage : sd_rd_wr x: file.dat [-w] [-o:offset] [-b:bytes] [-h]

Table 7: sd_rd_wr utility command line options

Paramter	Default when ommitted		Description
	reading	writing	
x:	always required	always required	drive letter of SD/MMC card
file.dat	always required	always required	source or desitination file name
-w	default		write daat from file.dat to SD/MMC card when omitted: read data from SD/MMC card and store in file.dat
-o:offset	0	0	decimal byte offset from address 0 of SD/MMC card
-b:bytes	512	size of file.dat	number of bytes to read or write
-h			display on-line help

Prototyping Hardware

Figure 5: Prototyping Hardware



The IP core comes with a small prototyping board that can be used together with El Camino or Altera NIOS boards that feature a Santa Cruz prototyping header. The schematics of the prototyping hardware can be

found at the end of this document. The SPI mode chip select, as well as the card detect and write protect switch signals can each be routed to one of two connector pins. This allows to cascade up to two SD/MMC prototyping boards. In such a cascaded configuration some signals need to be routed individually. Soldering bridges allow to put individual prototyping boards into an A or B configuration and de-activate the pull-up resistors on one of them. On a request basis, the prototyping boards can be outfitted with connectors that support cascading.

The following table lists the signal mapping.

Table 8: J2B Pin Descriptions

J2B Connector Pin	Schematic Signal	Connect to IP Core Signal	SD/MMC Pin	Function - SPI Bus Mode	Function - SD Bus Mode
3	SD_SD1		9	Reserved	Data Line [Bit 2]
4	SD_CMD	DI	2	Host to Card Commands and Data	Command/Response
5	SD_D1		8	Reserved	Data Line [Bit 1]
6	SD_CLK	SCLK	5	Clock	Clock
7	SD_SWWP_A	WP (default)			
8	SD_DAT	DO	7	Card to Host Data and Status	Data Line [Bit 0]
9	SD_SWWP_B	WP			
11	SD_SWCI_A	CDn (default)			
12	SD_D3CS_A	CSn (default)	1	Chip Select (Active Low)	Card Detect/Data Line [Bit 3]
13	SD_SWCI_B	CDn			
14	SD_D3CS_B	CSn	1	Chip Select (Active Low)	Card Detect/Data Line [Bit 3]

Custom Solutions

Please contact El Camino if you require any custom solutions based on this IP.

Notes:

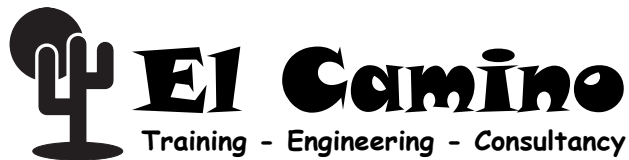

El Camino GmbH
Landshuter Str. 1
D-84048 Mainburg
Germany
Telephone +49-8751-8787-0
Telefax +49-8751-842876
E-mail: info@elca.de
<http://www.elcamino.de>

El Camino GmbH Training - Engineering - Consultancy, DIGILAB 10K10, DIGILAB picoMAX, DIGILAB 10Kx240, DIGILAB 20Kx240, DIGILAB megAPEX and other names of El Camino products, product features and services are trademarks and/or service marks of El Camino GmbH in Germany and other countries. Altera, APEX, Stratix, Quartus, NIOS and other names of Altera products, product features and services are trademarks and/or service marks of Altera Corporation in the United States and other countries. Other product and company names mentioned in this document may be the trademarks of their respective owners.

No warranties: This documentation is "as is" without any express or implied warranty of any kind including warranties of merchantability, no infringement of intellectual property or of fitness for any particular purpose. In no event shall El Camino or its suppliers be liable for any damages whatsoever (including, without limitation, damages for loss of profits, business interruption or loss of information) arising out of the use of or inability to use this documentation, even if El Camino has been advised of the possibility of such damages. Because some jurisdictions prohibit the exclusion or limitations of liability for consequential or incidental damages, some of the above limitations may not apply to you. El Camino further does not warrant the accuracy or completeness of the information, text, graphics or other items contained in this document. El Camino may make changes to these materials, or to the products described therein, at any time without notice. El Camino makes no commitment to update this document.

Copyright© 2004 El Camino GmbH. All rights reserved

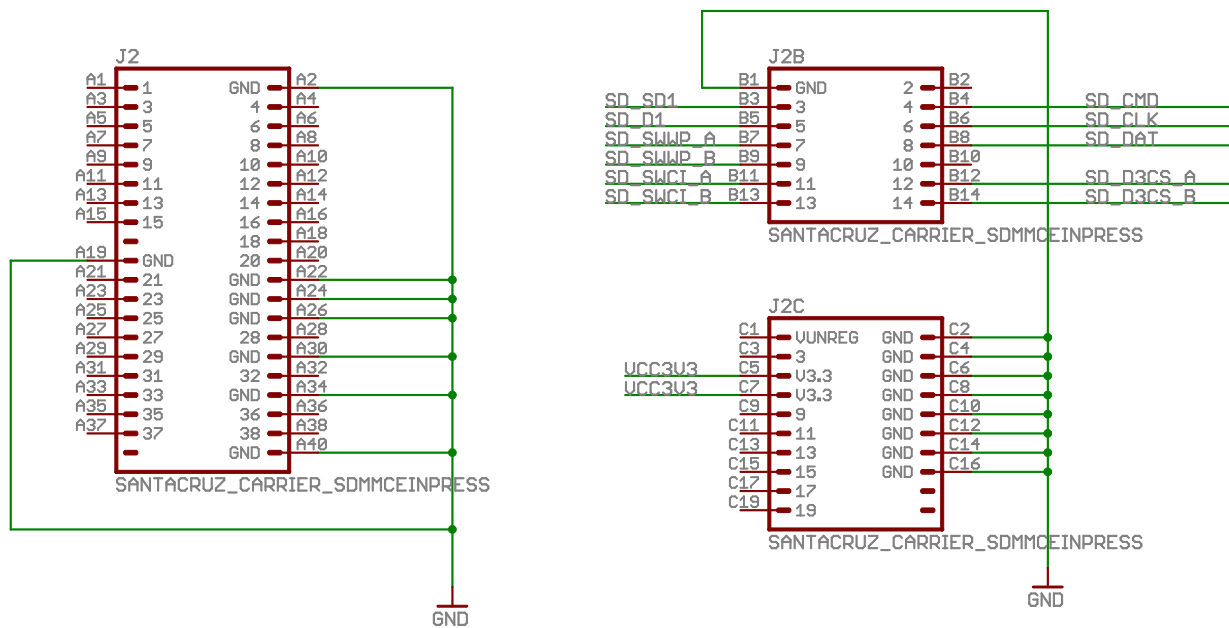

El Camino GmbH

TITLE: sc-header_SD-Adapter

Document Number:
040310_SC-header_SD-mem

REV:
1

Date: 01.07.2005 13:11:38

Sheet: 1/2

UCC3U3

R8	10K	BR6
R7	10K	BR5
R6	10K	BR4
R4	10K	BR3
R5	10K	BR2
R3	10K	BR1
R1	10K	
R2	10K	

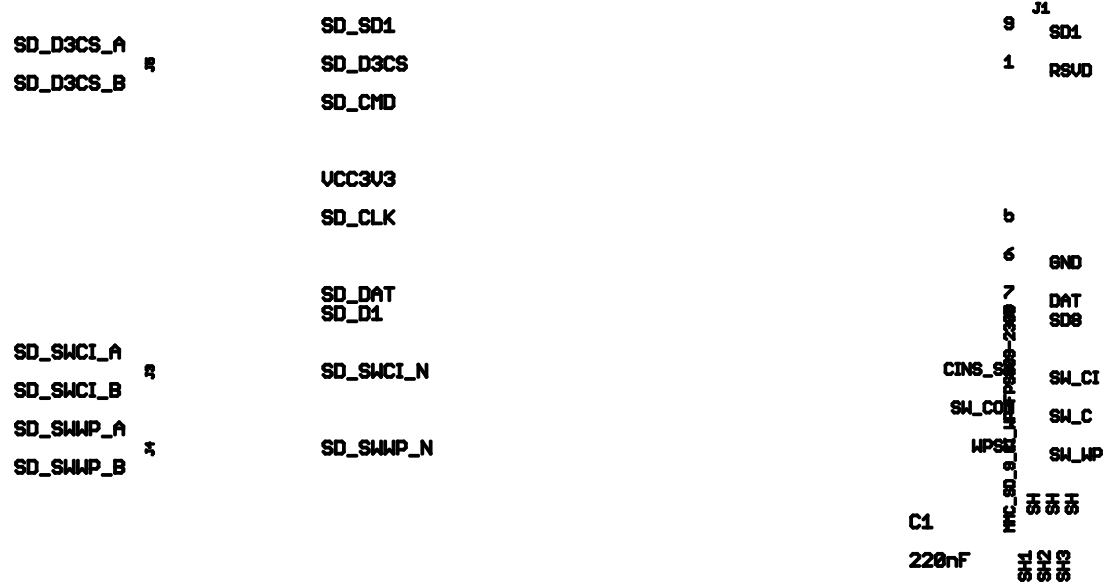

GND